

AIRBUS HELICOPTERS CANADA LIMITED
SUBJECT:

Required maintenance for the Airframe Fuel Filter (P/N 130-600004).

APPLICABILITY :

Aircraft with the subject modification embodied in accordance with TCCA STC No. SH02-42 or any relevant foreign approvals.

THE INFORMATION CONTAINED IN THIS DOCUMENT SHALL BE TREATED AS THE PROPERTY OF AIRBUS HELICOPTERS CANADA LIMITED (AHCA). THE RECIPIENT OF THIS DOCUMENT SHALL NOT DISCLOSE ANY INFORMATION CONTAINED HEREIN TO THIRD PARTIES WITHOUT THE WRITTEN PERMISSION OF AHCA, AND SHALL NOT USE OR REPRODUCE THIS DOCUMENT IN WHOLE OR IN PART FOR ANY PURPOSE OTHER THAN ITS ORIGINALLY INTENDED PURPOSE, OR TO EVALUATE ITS CONTENTS.

	NAME AND SIGNATURE	DATE	COMPANY DEPARTMENT
PREPARED BY:	D. Kerr <i>DKer</i>	17 th July 2015	AHCA ENGINEERING
PREPARED BY:			
CHECKED BY:	C. Timmins <i>C. Timmins</i>	17 th July 2015	AHCA ENGINEERING
CHECKED BY:	D. Kapuscinsky <i>Don Kapuscinsky</i>	JUL 17 2015	AHCA QUALITY ASSURANCE
REV. 9 ACCEPTED (Civil A/W Authority)	(As per ICA Compliance Check Sheet) <i>C. Timmins</i>	21 st July 2015	TCCA
REV. 9 RELEASED BY:	P. Sharpe <i>[Signature]</i>	JUL 21 2015	AHCA ENGINEERING

RECORD OF REVISIONS

Rev.	Pages at this Revision	Description, Reason Changed Pages	Prepared (name and date)	Checked (name and date)	App'd/Acc'd (Civil A/W Authority) (name and date)	Released (name and date)
0	1 through 9	Original Issue	D. Kerr 27 May, 2004	C. Timmins 27 May, 2004	TCCA E. Cheung 28 May, 2004	R. Manson 28 May, 2004
1	1 through 12	Changes to pages 1 to 12. Text, placard illustrations and assembly revised (re-designed installation for lower filter position)	D. Kerr 29 July, 2004	C. Timmins 30 July, 2004	N/A	R. Manson 4 Aug., 2004
2	1 through 13	Changes to pages 1 to 13. General, and Troubleshooting revised as per TCCA request.	D. Kerr 8 Sept., 2004	C. Timmins 8 Sept., 2004	TCCA E. Cheung 8 Sept., 2004	R. Manson 8 Sept., 2004
3	1 through 16 A1 to A4	Format revised. Weight and Balance data, torquing statement, and wiring diagram change incorporated. (Pages 4, 5, 7 - 16)	D. Kerr 22 February 2005	C. Timmins 2 March 2005	TCCA E. Cheung 24 March 2005	R. Manson 24 March 2005
4	1 through 22 A1 to A4	Format revised, Section 4 and 8 and Weight and Balance chart expanded. (Pages 3 to 6, 8 to 12, and 14 to 22)	D. Kerr 21 July 2006	C. Timmins 4 August 2006	TCCA Floyd Eaves 9 August 2006	R. Manson 9 August 2006
5	1 through 24 A1 to A4	Replaced "boost" pump reference with "fuel" pump in Sec. 4. Added placard to outboard side of Fuel Filter. Addition of page 24. (Pages 3 to 5, 8, 9, 11 to 16, 18, 20 to 24)	D. Kerr 28 March 2008	C. Timmins 28 March 2008	TCCA F. Eaves 7 April 2008	R. Manson 9 April 2008

NOTE: Revisions to this document will be distributed to operators of this equipment by the STC holder.

NOTE: Revised portions of affected pages are identified by a vertical black line in the margin adjacent to the change.

NOTE: Minor changes are released in accordance with TCCA - ACCEPTED CAR 521 - 154 procedures (ref. DAPM - E - 0001).

Transport Canada - Accepted

AIRBUS HELICOPTERS CANADA LIMITED
RECORD OF REVISIONS (continued)

Rev.	Pages at this Revision	Description, Reason Changed Pages	Prepared (name and date)	Checked (name and date)	App'd/Acc'd (Civil A/W Authority) (name and date)	Released (name and date)
6	1 through 25 A1 to A4	Revised format. Addition of 100 flight hour Press to Test. Increased 500 flight hour inspection to 600 flight hours and 1000 flight hours increased to 1200 flight hours. Wiring Diagram revised to incorporate wire changeover to laser printed. (Pages 4 to 9, 11 to 25)	D. Kerr 20 January 2012	C. Timmins 20 January 2012	N/A	R. Manson 20 April 2012
7	1 through 25 A1 to A4	Increased 100 flight hour to 150 flight hour. (Pages 4, 5, 9, 12, 16)	D. Kerr 31 May 2012	C. Timmins 31 May 2012	TCCA G. David 2012	R. Manson 21 December 2012
8	1 through 29 A1 to A4	Revised the Airworthiness Limitations statement in Section 2. Margins added to Section 4. Additional information added to Section 8. (Pages 7 to 14, 16 to 22, 24 to 29)	D. Kerr 2 April 2013	C. Timmins 2 April 2013	TCCA G. David 3 April 2013	P. Sharpe 8 April 2013
9	1 through 29 A1 to A4	Addition of new company logo. Template changes to pages 1, 2, 3 & 16. Revised the Airworthiness Limitations statement of Section 2. All references to ECL changed to AHCA. (Pages 10 to 13 & 16)	See page 1.	See page 1.	See page 1.	See page 1.

NOTE: Revisions to this document will be distributed to operators of this equipment by the STC holder.
 NOTE: Revised portions of affected pages are identified by a vertical black line in the margin adjacent to the change.
 NOTE: Minor changes are released in accordance with TCCA - ACCEPTED CAR 521 - 154 procedures (ref. DAPM - E - 0001).

Transport Canada - Accepted

CONTENTS

SECTION	TITLE	PAGE
1	GENERAL	6
2	AIRWORTHINESS LIMITATIONS	11
3	CONTROL AND OPERATION	12
4	INSPECTION SCHEDULE AND MAINTENANCE ACTION	12
5	REPLACEMENT COMPONENTS AND REPAIR/OVERHAUL INFORMATION ..	16
6	TROUBLESHOOTING	16
7	SPECIAL TOOLING	18
8	REMOVAL AND REPLACEMENT	18
9	WEIGHT AND BALANCE	23
10	PLACARDS AND MARKINGS	20
Appendix A	PUROLATOR PRODUCTS COMPANY - Operating & Design Specifications (4 pages)	

FIGURES

FIGURE	TITLE	PAGE
1	General Layout	6
2	Airframe Fuel Filter Installation	7
3	Side view of Airframe Fuel Filter Installation	8
4	Floor Doubler and Base Installation Details	9
5	Airframe Fuel Filter, Wiring Diagram	17
6	Typical label location on the Fuel Filter Support Assembly	24
7	Typical label location on the Fuel Filter	25
8	Typical label location in LH Baggage Compartment	26
9	Typical label location on the Cover Assembly	27
10	Typical label locations on the Instrument Panel	28
11	Typical location for identification tags on hoses	29

Transport Canada - Accepted

TABLES

TABLE	TITLE	PAGE
1	Inspection Schedule and Maintenance Action Before the first flight of each day	12
2	Inspection Schedule and Maintenance Action Pre-Flight Check	12
3	Inspection Schedule and Maintenance Action Every 150 FH or 12 M (Margin: 15 FH or 36 D)	13
4	Inspection Schedule and Maintenance Action Every 600 FH or 24 M (Margin: 60 FH or 73 D)	14
5	Inspection Schedule and Maintenance Action Every 1200 FH or 48 M (Margin: 120 FH or 145 D)	14
6	Troubleshooting Guide	16

Transport Canada - Accepted

AIRBUS HELICOPTERS CANADA LIMITED

1. GENERAL

- A. The Airframe Fuel Filter enables operation of the helicopter at low temperatures without the use of anti-ice additives in the fuel. The filter is designed to collect ice particles. The filter contains a bypass valve and a bypass delta pressure switch. An annunciator light in the cockpit is provided to warn the pilot of an impending bypass of the filter. Refer to Figure 1 for General Layout.

The Airframe Fuel Filter consists of the following main components:

Fixed Provisions

- Fuel Filter Support Assembly
- Fuel Filter Base Assembly
- Cover Assembly
- Drain Sump Assembly
- Angle
- Floor Doubler
- Floor Shim
- Drain Bracket
- Gusset

Detachable Provisions

- Fuel Filter
- Hoses

For instructions for initial installation, see IP-ECL-105.

- B. These Instructions for Continued Airworthiness are applicable to aircraft with the subject modification embodied.

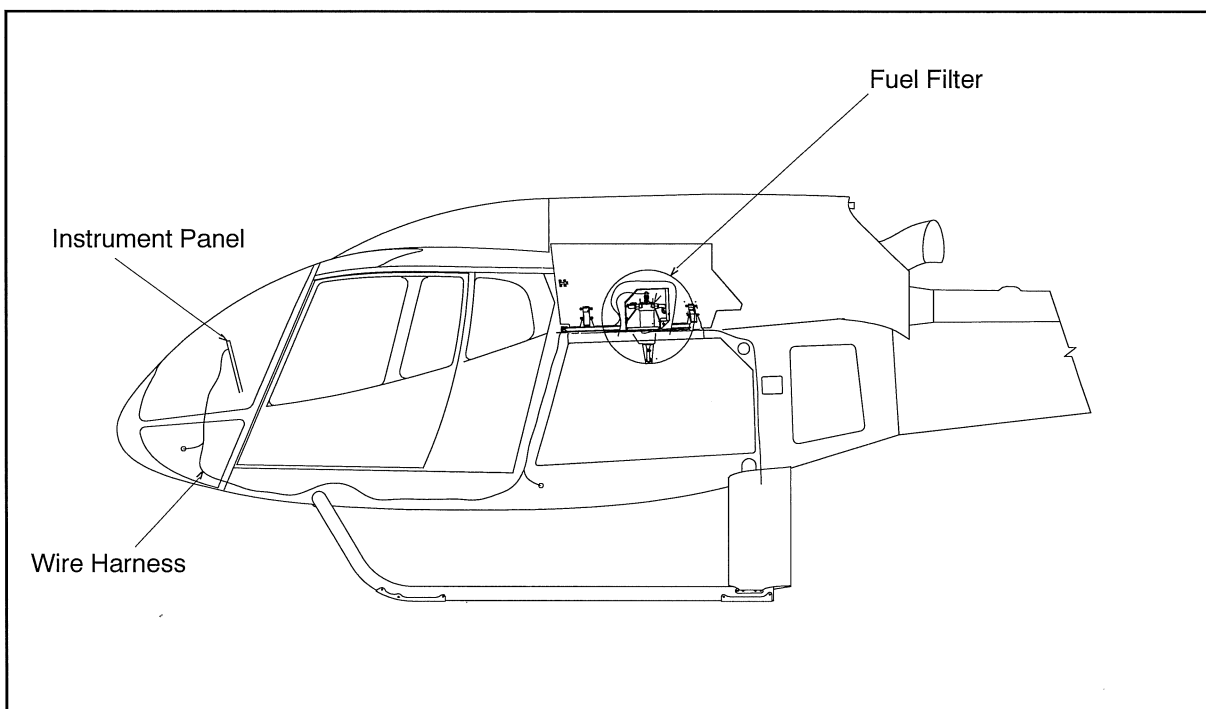

Figure 1 General Layout

Transport Canada - Accepted

AIRBUS HELICOPTERS CANADA LIMITED

Figure 2 Airframe Fuel Filter Installation

Transport Canada - Accepted

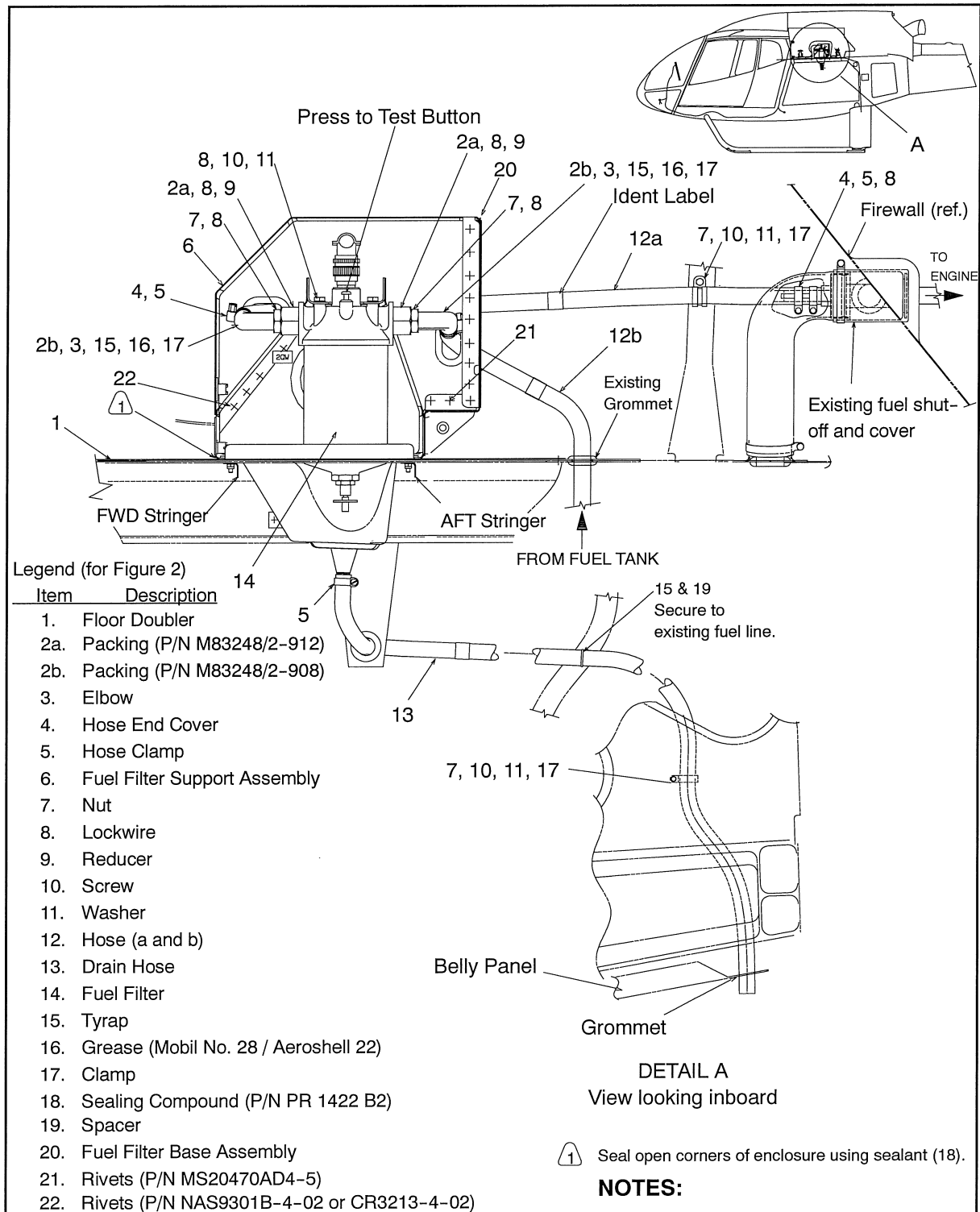
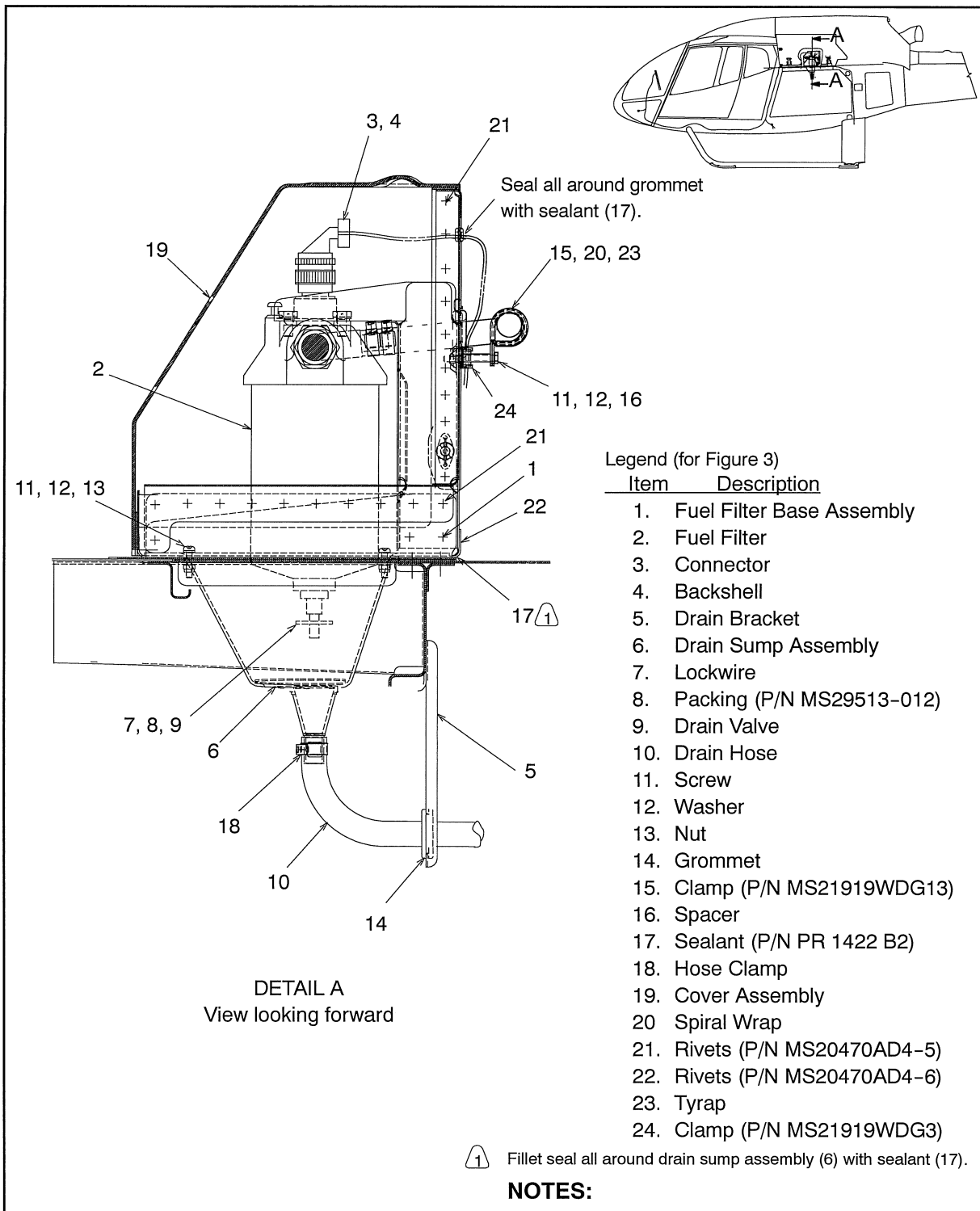

Figure 3 Side view of Airframe Fuel Filter Installation

Transport Canada - Accepted

Legend (for Figure 4)

Item	Description
------	-------------

- | | | | |
|----|-----------------------------------|----|---------------------------|
| 1. | Floor Doubler | 5. | Rivets (BJ MS20470AD) |
| 2. | Fuel Filter Base Assembly | 6. | Rivets (BB MS20426AD) |
| 3. | Floor Shim | 7. | Rivets (LN MS20615-() M) |
| 4. | Sealing Compound (P/N PR 1422 B2) | 8. | Rivets (LZ NAS1097AD) |

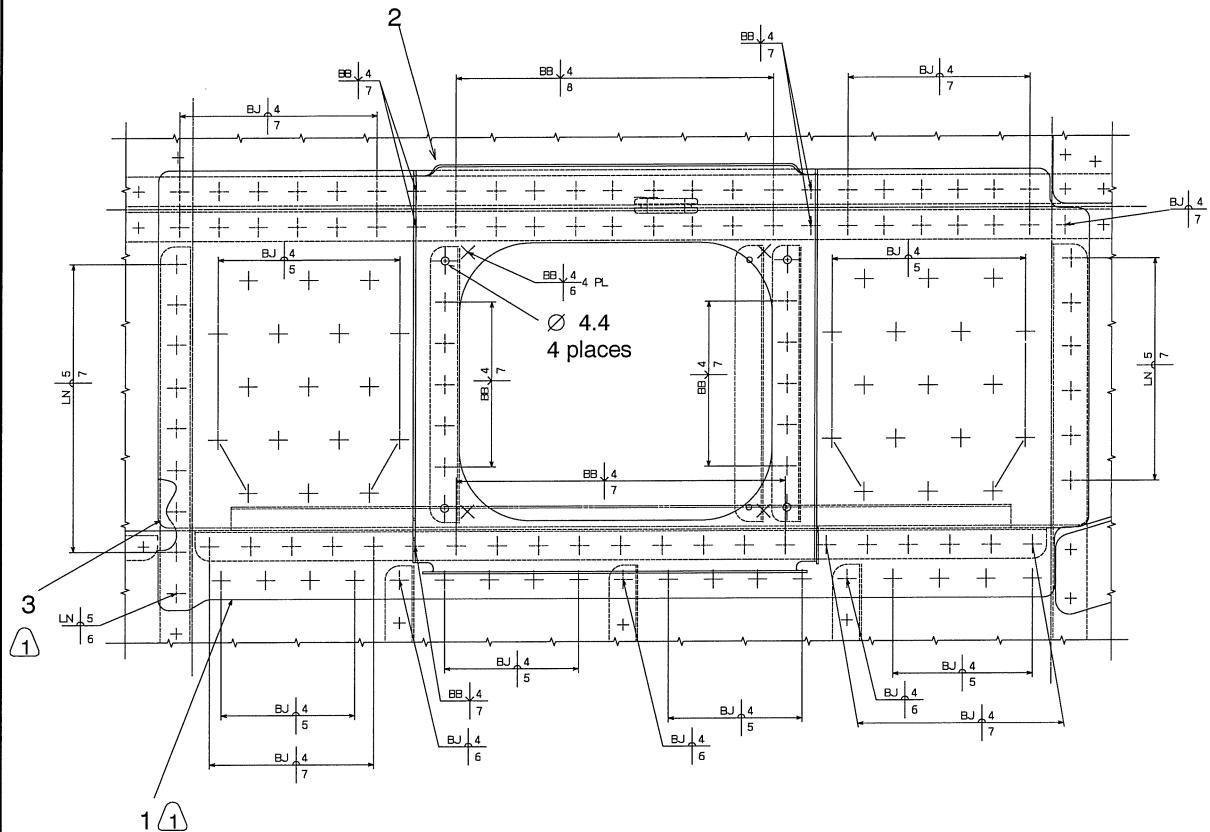

View looking down on Transmission Deck
Cover Assembly, Drain Sump Assembly and Filter not shown

- (1) Seal faying surface and fillet seal edge of floor doubler (1) and floor shim (3) to transmission deck using sealant (4).

NOTES:

Figure 4 Floor Doubler and Fuel Filter Base Assembly Installation Details

AIRBUS HELICOPTERS CANADA LIMITED
C. REFERENCES

DOCUMENT	DOCUMENT TITLE
AC 43.13 - 1B	Advisory Circular, Acceptable Methods, Techniques and Practices - Aircraft Inspection and Repair
AMM	Aircraft Maintenance Manual
MTC	Standard Practices Manual
IP-ECL-105	Installation Procedure, Airframe Fuel Filter
Manual Number 1743640-01	"Operating and Design Specifications", Fuel Filter Assembly, Purolator Products Company

D. ABBREVIATIONS & DEFINITIONS

ABBREVIATION	DEFINITION
Acc'd	Accepted
A/F	Airframe
AHCA	Airbus Helicopters Canada Limited
App'd	Approved
A/W	Airworthiness
CAR	Canadian Aviation Regulations
D	Days
DAPM	Design Approval Procedure Manual
D.BAT	Direct Battery
EC	Eurocopter (France)
ECL	Eurocopter Canada Limited
EPU	External Power Unit
EXT PWR BAT	External Power Battery
FH	Flight Hours
ICA	Instructions for Continued Airworthiness
M	Months
No.	Number
P/N	Part Number
STC	Supplemental Type Certificate
TCCA	Transport Canada Civil Aviation

E. UNITS OF MEASUREMENT

ABBREVIATION/SYMBOL	UNIT OF MEASUREMENT
in	inch
kg	kilogram
lb	pound
m	meter
§§	sections

Transport Canada Accepted

2. AIRWORTHINESS LIMITATIONS

The Airworthiness Limitations section is approved by the Minister and specifies maintenance required by any applicable airworthiness or operating rule unless an alternative program has been approved by the Minister. Variations must also be approved.

The Airworthiness Limitations section is FAA approved and specifies inspections and other maintenance required under §§43.16 and 91.403 of the Federal Aviation Regulations unless an alternative program has been FAA approved. ■

The Airworthiness Limitations section is approved and variations must also be approved. ■

No airworthiness limitations associated with this installation.

Transport Canada - Approved

AIRBUS HELICOPTERS CANADA LIMITED
3. CONTROL AND OPERATION

Control and operation of the aircraft remains unchanged.

4. INSPECTION SCHEDULE AND MAINTENANCE ACTION

For additional information on operation and maintenance, refer to the "Purolator" Operating and Design Specifications, Fuel Filter Assembly manual, Part No.: 1743640-01, located in Appendix A.

NOTE: Use torque per MTC, Chapter 20.02.05.404, unless otherwise specified.

Remove cover to gain access to filter assembly and re-install after inspection/maintenance.

4.1. INSPECTION SCHEDULE
4.1.1. Before the first flight of each day:

ITEM	INSPECTION OR MAINTENANCE WORK	CORRECTIVE ACTION
A	- Turn on fuel pump and check Airframe Fuel Filter for: a. water in fuel b. air in fuel line c. leaks in the fuel filter and the drain valve	a. Open drain valve, purge any water from the system. b. Hold drain valve open until all air is purged. c. No leaks with fuel pump on. Check valve seating, replace packing, item 8, in Figure 3 as necessary (P/N MS29513-012).
B	- Turn off fuel pump and check Airframe Fuel Filter for: a. debris in fuel drain, below the filter and/or on the transmission deck b. secure mounting and connection of filter and hoses c. condition of electrical connector and harness	a. Remove and clean as necessary. b. Secure as required. c. If cracks, fraying or burns are found, contact AHCA for replacement parts.

Table 1 Inspection Schedule and Maintenance Action
 Before the first flight of each day

NOTE: The "Before the first flight of each day" task can be carried out by a suitably trained pilot or maintenance personnel.

4.1.2. Pre-Flight Check:

ITEM	INSPECTION OR MAINTENANCE WORK	CORRECTIVE ACTION
A	- Push A/F FUEL FILTER by-pass "Press to Test" caution light: a. apply power to 4 Alpha Warning Panel (Master/Battery switch to ON) and push Press to Test A/F FUEL FILTER annunciator - lamp must illuminate.	a. If lamp fails to illuminate, refer to Chapter 6, Troubleshooting, item 1, in this document.

Table 2 Inspection Schedule and Maintenance Action
 Pre-Flight Check

NOTE: The "Pre-Flight Check" task can be carried out by a suitably trained pilot or maintenance personnel.

Transport Canada - Accepted

AIRBUS HELICOPTERS CANADA LIMITED
4. INSPECTION SCHEDULE AND MAINTENANCE ACTION (continued)

4.1.3. Every 150 FH or 12 M (Margin: 15 FH or 36 D) to coincide with the 150 FH or 12 M helicopter inspection, whichever occurs first:

ITEM	INSPECTION OR MAINTENANCE WORK	CORRECTIVE ACTION
A	<ul style="list-style-type: none"> - Push the Press to Test Button on the Fuel Filter shown in Figure 2: a. Push the Press to Test Button on the Fuel Filter, the A/F FUEL FILTER annunciator – lamp must illuminate. 	<ul style="list-style-type: none"> a. If lamp fails to illuminate, refer to Chapter 6, Troubleshooting, item 2, in this document.
B	<ul style="list-style-type: none"> - Check doubler, item 1, and fuel filter support assembly, item 6, in Figure 2 for: a. cracks or corrosion 	<ul style="list-style-type: none"> a. No cracks or corrosion are allowed. If cracks or deformation are found, contact AHCA for replacement parts.
C	<ul style="list-style-type: none"> - Check hoses, item 12, and drain hose, item 13, in Figure 2 for: a. leaks b. cracking 	<ul style="list-style-type: none"> a. If leaks are found, contact AHCA for replacement parts. b. No cracking is allowed. If cracking is found, contact AHCA for replacement parts.
D	<ul style="list-style-type: none"> - Check base, item 10, and drain bracket, item 5, in Figure 3 for: a. cracks or corrosion 	<ul style="list-style-type: none"> a. No cracks or corrosion are allowed. If cracks or deformation are found, contact AHCA for replacement parts.
E	<ul style="list-style-type: none"> - Check drain sump assembly, item 6, in Figure 3 for: a. cracks or deformation 	<ul style="list-style-type: none"> a. No cracks or deformation are allowed. If cracks or deformation are found, contact AHCA for replacement parts.
F	<ul style="list-style-type: none"> - Check placards and markings in Figures 6, 7, 8, 9, 10 and 11 (Section 10) for: a. legibility b. secure mounting 	<ul style="list-style-type: none"> a. If placards and markings have become illegible, contact AHCA for replacement parts. b. Secure, reattach placards as required.

Table 3 Inspection Schedule and Maintenance Action
 Every 150 FH or 12 M, to coincide with the 150 FH or 12 M helicopter inspection,
 whichever occurs first

Transport Canada – Accepted

4. INSPECTION SCHEDULE AND MAINTENANCE ACTION (continued)

4.1.4. Every 600 FH or 24 M (Margin: 60 FH or 73 D) to coincide with the 600 FH or 24 M helicopter inspection, whichever occurs first:

ITEM	INSPECTION OR MAINTENANCE WORK	CORRECTIVE ACTION
A	Perform Operational Test - Fuel Filter Switch and Bypass Valve	See Operational Test Instructions given following Table 5

Table 4 Inspection Schedule and Maintenance Action
 Every 600 FH or 24 M, to coincide with the 600 FH or 24 M helicopter inspection, whichever occurs first

4.1.5. Every 1200 FH or 48 M (Margin: 120 FH or 145 D) to coincide with the 1200 FH or 48 M helicopter inspection, whichever occurs first:

ITEM	INSPECTION OR MAINTENANCE WORK	CORRECTIVE ACTION
A	Replace Fuel Filter Element	See Replacement Instructions given following Table 5

Table 5 Inspection Schedule and Maintenance Action
 Every 1200 FH or 48 M, to coincide with the 1200 FH or 23 M helicopter inspection, whichever occurs first

NOTE Filter Element can be replaced more frequently if operational elements dictate.

NOTE: Should the A/F FUEL FILTER annunciator light illuminate, the fuel filter element must be replaced.



A/F FUEL
 FILTER

A partially blocked filter element will cause a differential pressure switch in the head assembly to close and the A/F FUEL FILTER annunciator to illuminate. If the filter element becomes fully blocked a differential pressure activated valve will permit fuel to bypass the filter.

Transport Canada - Accepted

AIRBUS HELICOPTERS CANADA LIMITED**4. INSPECTION SCHEDULE AND MAINTENANCE ACTION (continued)**Operational Test - Fuel Filter Switch and Bypass Valve

- a. Observe FUEL SYSTEM General Safety Instructions. Refer to AMM, Chapter 28-00-00, 3-1.
- b. Remove cover from enclosure.
- c. Apply power to annunciator panel. Press differential pressure switch Test Button, on the top of the fuel filter, A/F FUEL FILTER annunciator must illuminate.
- d. Replace filter element with clean dummy element.
- e. Turn on fuel pump and start engine.
- f. The A/F FUEL FILTER annunciator should illuminate.
- g. When test is successfully completed, shut down engine. Remove dummy element and install filter element. Follow instructions given in Chapter 4, Replacement - Fuel Filter Element.
- h. Open fuel filter bowl drain and operate fuel pump until all air is purged.
- i. Replace cover of enclosure.

Replacement - Fuel Filter Element

- a. Observe FUEL SYSTEM General Safety Instructions. Refer to AMM, Chapter 28-00-00, 3-1.
- b. Remove cover from enclosure.
- c. Drain fuel from filter bowl into a container.
- d. Refer to Appendix A "Operating Instructions" Purolator Products Company for Fuel Filter Element Change.
- e. Operate fuel pump and open fuel filter bowl drain until all air is purged.

NOTE: The Purolator Filter Assembly (Part No. 1743640-01) Replacement Element Kit is also available, Purolator Products Company Part No. 1743645.02. This kit consists of a Seal, an O-ring and an Element Assembly.

Transport Canada - Accepted

AIRBUS HELICOPTERS CANADA LIMITED
5. REPLACEMENT COMPONENTS AND REPAIR / OVERHAUL INFORMATION

Contact AHCA for replacement parts. No overhaul information required for this installation.

For replacement components or repair information:

Airbus Helicopters Canada Limited

1100 Gilmore Road, P.O. Box 250

Fort Erie, Ontario L2A 5M4 Canada

Telephone (905) 871-7772

Telefax: (905) 871-3599

Website: www.airbushelicopters.ca

6. TROUBLESHOOTING

There are no unique characteristics which require special troubleshooting techniques; standard techniques are adequate.

For electrical system troubleshooting, refer to Figure 5, Airframe Fuel Filter, Wiring Diagram.

Remove cover to gain access to filter assembly and re-install after maintenance.

ITEM	TROUBLE SYMPTOM	PROBABLE CAUSE	CORRECTIVE ACTION
1	A/F FUEL FILTER lamp does not illuminate during Daily Preflight Inspection.	Bulb burnt out.	Replace bulb, P/N MS25237-327
2	A/F FUEL FILTER lamp does not illuminate during either the 150 flight hours check or the Operational Test (600 flight hours check).	Break or short in annunciator circuit Fuel Filter Head Assembly defective	Perform circuit continuity check and repair/replace wiring as applicable in accordance with AC 43.13-1B, Chapter 11, Section 1. Replace Head Assembly, refer to the Purolator Documentation
3	A/F FUEL FILTER illuminates during operations.	Excessive contamination in fuel supply. Filter is blocked prematurely. Short in annunciator circuit.	Check quality of fuel supply. Replace filter element. Perform circuit continuity check and repair/replace wiring as applicable in accordance with AC 43.13-1B, Chapter 11, Section 1.

Table 6 Troubleshooting Guide

Transport Canada - Accepted

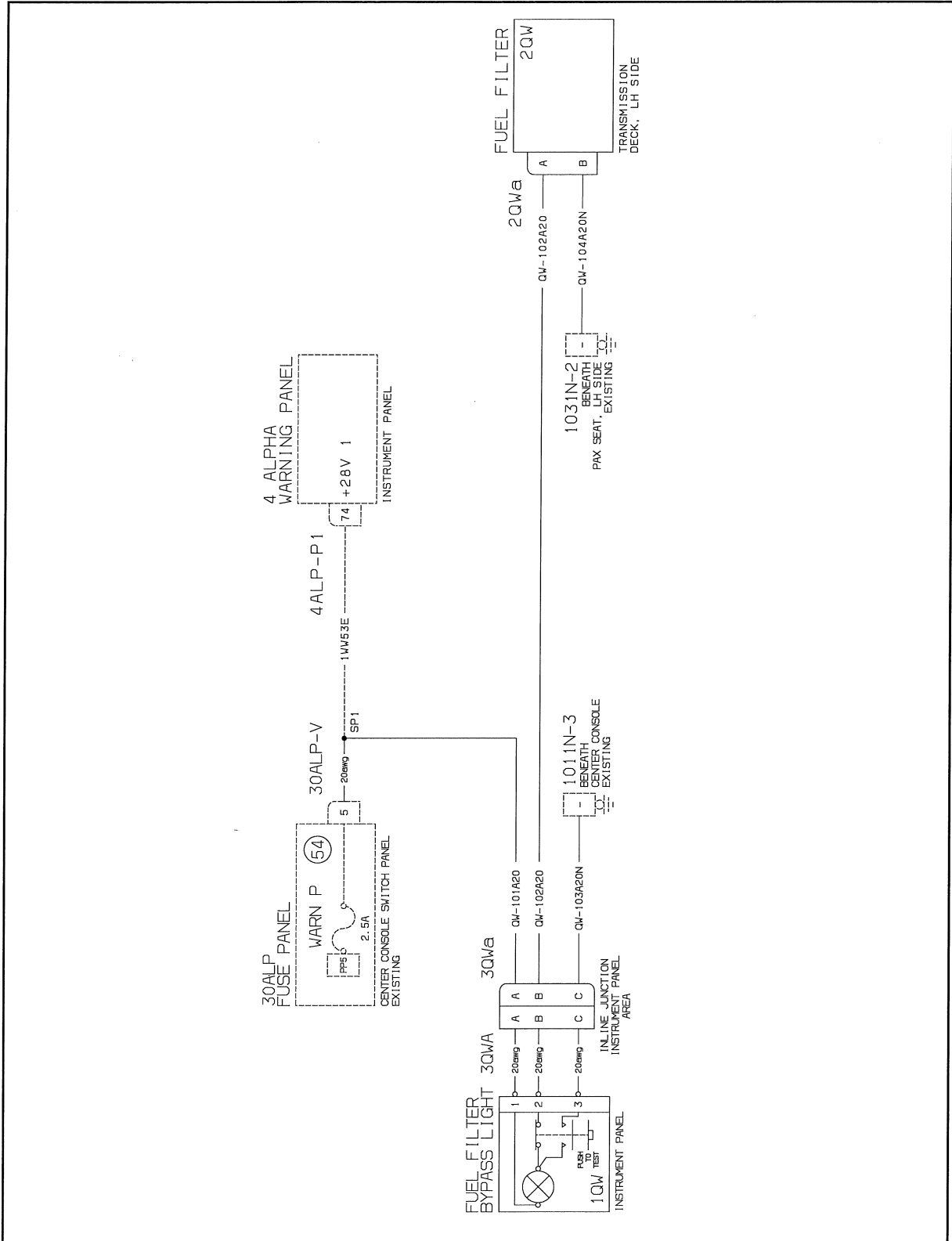

Figure 5 Airframe Fuel Filter, Wiring Diagram

Transport Canada - Accepted

AIRBUS HELICOPTERS CANADA LIMITED

7. SPECIAL TOOLING

No special test equipment or tools are required. Standard tools are adequate.

8. REMOVAL AND REPLACEMENT

Proceed as follows if fuel filter needs to be removed.

Preliminaries

- Read General Safety Instruction - Electrical Power Supply System (EC 130 AMM, Chapter 24-00-00, 3-1)
- set the "D.BAT" pushbutton to "OFF" (refer to Removal/Installation EC 130 AMM, Chapter 24-33-00, 4-1)
- set the "EXT PWR BAT" of "BAT EPU" (depending on MOD) pushbutton to "OFF" - (refer to Electrical Power Supply on the Ground, EC 130 AMM, Chapter 24-00-00, 2-1)
- disconnect the external power unit and battery (refer to Removal/Installation EC 130 AMM, Chapter 24-33-00, 4-1)
- Observe Fuel System General Instructions. Refer to AMM, Chapter 28-00-00, 3-1.
- open the engine and left MGB cowlings (Removal / Installation - Upper Cowling - refer to AMM, Chapter 53-51-00, 4-1)
- Remove cover to gain access to filter assembly.

A. REMOVAL

1) HOSES (Refer to Figures 2 and 3)

- a) Disconnect hose clamps (5) and spiral wrap if applicable and remove hose (12 a or b). Close hose end cover (4). Retain hose clamps (5), hose end covers (4) and spiral wrap for reinstallation. Refer to Figures 2 and 3.
- b) Remove packing (2 b) from elbow (3) and discard packing. Refer to Figure 2.

NOTE: If hose (12 a or b) are not being replaced, position hose out of work area and close hose end covers (4). Refer to Figure 2.

NOTE: Reuse clamps, hose end covers and spiral wrap from existing hose.

Transport Canada - Accepted

AIRBUS HELICOPTERS CANADA LIMITED**8. REMOVAL AND REPLACEMENT (continued)****A. REMOVAL (continued)****2) FUEL FILTER (Refer to Figures 2 and 3)**

- a) Disconnect hoses on either side of the Fuel Filter. Follow instructions given above.
- b) Disconnect connector (3) and backshell (4) from fuel filter (2) and position wire out of working area. Refer to Figure 3.
- c) If replacing the fuel filter support assembly (6, in Figure 2), disconnect the wire harness from connector (3). Carefully pull harness through grommet located in the back of the fuel filter base assembly.(1). Remove screw (11), washer (12), spacer (16) and clamp (24) securing the harness to fuel filter (2). Retain hardware for reinstallation.
- d) Remove lockwire (8), screws (10, 3 places), and washers (11, 3 places) that secure the fuel filter (14) to top of fuel filter support assembly (6). Refer to Figure 2.
- e) Remove fuel filter (14). Retain screws (10) and washers (11) for reinstallation.

3) FUEL FILTER WIRING

- a) Remove damaged Airframe Fuel Filter wire or component.

4) DRAIN SUMP ASSEMBLY, DRAIN BRACKET, FUEL FILTER BASE ASSEMBLY, FUEL FILTER SUPPORT ASSEMBLY & FLOOR DOUBLER (Refer to Figures 2, 3 and 4)

- a) Remove the Fuel Filter. Follow instructions given above.
- b) To remove the drain sump assembly (6) disconnect the hose clamp (18) and remove hose (10). Remove screws (11, 4 places), washers (12, 8 places) and nuts (13, 4 places). Refer to Figure 3.
- c) Remove drain bracket (5) from rear bulk head and discard. Retain grommet (14) for reinstallation. Refer to Figure 3.
- d) If drain hose (13) is being replaced retain hardware. Refer to Figure 2.
- e) Drill out rivets securing the fuel filter base assembly (1, shown in Figure 2) to the floor doubler (1, shown in Figure 3). If replacing the fuel filter base assembly or fuel filter support assembly (6), drill out rivets and discard damaged part. Refer to Figure 2.
- f) Drill out rivets securing the floor doubler (1) and shim (3) to the transmission deck. Refer to Figures 2 and 4.
- g) Retain existing fwd and aft stringers located under the transmission deck.

Transport Canada - Accepted

AIRBUS HELICOPTERS CANADA LIMITED**8. REMOVAL AND REPLACEMENT (continued)****B. REPLACEMENT**

NOTE Use torque per MTC, Volume 2, Chapter 20.02.05.404, unless otherwise specified.

Safetying with Lockwire – refer to Safetying with Lockwire – MTC, Chapter 20-02-06-402.

Sealing compound PR-1422 B2 – refer to General methods for applying sealing compounds – MTC, Chapter 20.05.01.102 and Application of PR 1422 B sealant – MTC, Chapter 20-05-01-206.

Observe General Safety Instructions – Fuel System, refer to EC 130 B4, AMM, Chapter 28-00-00, 3-1.

Electrical Bonding – refer to Electrical Bonding – General, MTC, Chapter 20.02.07.101.

- 1) DRAIN SUMP ASSEMBLY, DRAIN BRACKET, FUEL FILTER BASE ASSEMBLY, FUEL FILTER SUPPORT ASSEMBLY & FLOOR DOUBLER (Refer to Figures 2, 3 and 4)
 - a) If replacing drain bracket (5), position drain bracket (5) onto rear bulkhead and secure using rivets (5 places [MS20470AD]) and reinstall grommet (14). Refer to Figure 3.
 - b) Position new floor doubler (1) onto transmission deck. Align opening and existing rivet holes. Temporarily secure to the transmission deck and match drill existing holes from the transmission deck into the floor doubler (1). Open 4 holes to 4.4 mm diameter as shown in Figure 4.
 - c) Position fuel filter base assembly (2) onto floor doubler (1). If replacing base, match drill holes from floor doubler (1) into fuel filter base assembly (2). Position fuel filter support assembly (6) onto base aligning pilot holes. Open up any pilot holes, copy drill remaining holes.
 - d) If replacing drain sump assembly (3), Temporarily position the drain sump assembly (3) into fuel filter base assembly (2) and match drill 4 pilot holes from fuel filter base assembly (2) into drain sump assembly (3). Refer to Figure 3.
 - e) Remove drain sump assembly (3), fuel filter support assembly (6), fuel filter base assembly (2) and floor doubler (1) from the transmission deck and deburr all newly drilled holes.
 - f) Reposition shim (3) and floor doubler (1) onto transmission deck and secure into place using rivets: (MS20470AD4-7, MS20470AD4-5, MS20615-()M5-7, MS20470AD4-6 and MS20426AD. Refer to Figure 4.
 - g) Seal faying surfaces and fillet seal edges of floor doubler (1) and shim (3) to transmission deck using sealant (4). Refer to NOTE 1 in Figure 4. Refer to General Sealing Procedures – MTC, Chapter 20.05.01.206.
 - h) Position the fuel filter support assembly (6) onto fuel filter base assembly (2) and secure into place using rivets (21, shown in Figure 2) and rivets (21 & 22, shown in Figure 3).
 - i) Position fuel filter base assembly (2) onto floor doubler (1) and secure using rivets (MS20426AD4-8, and MS20426AD4-7). Reposition previously removed AFT and FWD stringer to the edge of the cutout under the transmission deck and secure using rivets (MS20426AD4-7).
 - j) Seal open corners of enclosure using sealant (17). Refer to General Sealing Procedures – MTC, Chapter 20.05.01.206.

Transport Canada – Accepted

AIRBUS HELICOPTERS CANADA LIMITED**8. REMOVAL AND REPLACEMENT (continued)****B. REPLACEMENT (continued)**

NOTE: Do not seal between plate (23) and drain sump assembly (9).

- k) Position the drain sump assembly onto the fuel filter base assembly (2) and secure using screw (11, 4 places), washers (12, 4 places) and nuts (13, 4 places).
- l) Fillet seal all around drain sump assembly with sealant (17). Refer to General Sealing Procedures – MTC, Chapter 20.05.01.206.
- m) Reposition plate onto the fuel filter support assembly (6) and secure using rivets (22). Refer to Figure 2.
- n) Position the fuel filter (16) in the top angle of the fuel filter support assembly (2). Secure into place using washer (11), and screw (10). Torque screw to required specification and secure with lockwire (8). Refer to Figure 2. Refer to Safelying with Lockwire, MTC, Chapter 20-02-06-402.

2) HOSES (Refer to Figures 2 and 3)

NOTE: Reuse clamps, hose end cover and spiral wrap from existing hose.

NOTE: Apply grease (16) to the nipple of the elbow (3) and to the inside diameter of the hoses (12 a and b) before installation. Refer to Figure 2.

NOTE: To avoid any low or high spots in the routing of the fuel line hoses (12 a or b) and to produce the least strain on the hoses, adjust the angle of elbows (3).

- a) If replacing either hose from fuel filter, repack FWD elbow (3) with packing (2 b).
- b) If replacing hose (12 a), install existing hose end cover (4) into one end of hose (12 a). Connect hose to FWD elbow (3) on the fuel filter. Hose end cover (4) to be opened up to fit elbow (3).
- c) Trim opposite end of hose (12 a) to the required length to connect it to the existing fuel shut off hose. Install existing hose cover (4) into end of hose and secure to fuel shut off hose. Refer to Figure 2.
- d) Install spiral wrap on hose (12 a) at point of contact with hose clamp (15). Refer to Figure 3.
- e) If replacing hose (12 b), route the hose (12 b) from the fuel tank, through the existing grommet in the transmission deck.
- f) Install the hose end cover (4) into the hose (12 b), connect the hose to the AFT elbow (3). Hose end cover (4) to be opened up to fit aft elbow (3).
- g) Once hoses are adjusted secure using clamps (17).
- h) If replacing drain hose (10), connect the drain hose (10) to the drain sump assembly (6) and secure using hose clamp (18). Route hose through grommet (14) in drain bracket (5). Refer to Figure 3.
- i) Place spacer (19) between existing fuel line drain hose (13) and secure to existing fuel line using two ty-raps (15). Refer to Figure 2.
- j) Route the drain hose (13) behind cargo panel and secure clamp (17) to existing tooling hole using screw (10), washer (11) and nut (7).
- k) Run drain hose (13) through existing grommet in belly panel and trim hose as required.
- l) Install new identification tag on replaced hose (12 a or b).

Transport Canada - Accepted

AIRBUS HELICOPTERS CANADA LIMITED**8. REMOVAL AND REPLACEMENT (continued)****B. REPLACEMENT (continued)****3) FUEL FILTER (Refer to Figures 2 and 3)**

- a) Position fuel filter (14) into fuel filter support assembly (2) and secure using previously removed screws (10, 3 places), and washers (11, 3 places). Torque screws to required specifications and secure using lockwire (8). Refer to Figure 2.
- b) Repack elbow (3, 1 place) on LHS of fuel filter (14) with new packing (2b, 1 place). Reconnect hose (12 a) to elbow (3) and secure reusing hose clamps (5, 2 places).
- c) Repack elbow (4, 1 place) on RHS of fuel filter (14) with new packing (2a, 1 place). Reconnect hose (12 b) to elbow (3) and secure reusing hose clamps (5, 2 places).

NOTE Apply grease (16) to the nipple of elbows (3, 2 places) and to the inside diameter of the hoses (12 a and b, 2 places) before installation.

- d) Bring the harness through the grommet in the back of the fuel filter support assembly (6, in Figure 2) and reattach to connector (3). Attach the backshell (4) and connector (3) to the top of fuel filter (2). Secure harness to the back of the fuel filter support assembly with screws (11), washers (12), clamp (24) and spacer (16). Seal all around grommet with sealant (17).
- e) If a new fuel filter has been installed, ensure ident label, shown in Figure 7 is installed facing outboard after fuel filter installation.

4) FUEL FILTER WIRING

- a) Refer to Airframe Fuel Filter wiring drawings in this document to replace damaged components or wiring.
 - b) Install in accordance with AC43.13-1B, Chapter 11.
 - c) Check electrical bonding in accordance with AC 43.13-1B, Chapter 11, Section 15, Paragraph 11-189.
- 5) Check After Maintenance Work - Fuel System in accordance with EC 130 B4 AMM, Chapter 28-00-01, 6-2.
 - 6) Install the Purolator Dummy Filter Test Element (P/N 1741185), as per this document, and using the Purolator Operating Instruction for the filter assembly contained in this document in Appendix A, check for the correct operation of the fuel filter bypass function.
 - 7) Install the fuel filter element, and perform a leak check on runup.
 - 8) Close all areas opened for service in the PRELIMINARIES paragraph of this section.
 - 9) Before energizing the aircraft power supply system, read safety instructions (refer to Electrical Power Supply on the Ground, EC 130 AMM, Chapter 24-00-00, 2-1).
 - 10) Reconnect the external power unit and battery (refer to Removal/Installation, EC 130 AMM, Chapter 24-33-00, 4-1).
 - 11) Perform functional test in accordance with EC 130 AMM, Chapter 24-30-00, 5-1.
 - 12) Reposition cover on filter assembly.
 - 13) Close left MGB and engine cowlings.

Transport Canada - Accepted

AIRBUS HELICOPTERS CANADA LIMITED
9. WEIGHT AND BALANCE DATA
A. Removed Items

DESCRIPTION	WEIGHT		ARM		MOMENT	
	kg	lbs	m	in	kg m	lb in
Floor Cut-out	0.09	0.2	3.47	136.8	0.31	27.36
Total	-0.09	-0.2	3.47	136.8	-0.31	-27.36

B. Added Items

DESCRIPTION	WEIGHT		ARM		MOMENT	
	kg	lbs	m	in	kg m	lb in
Airframe Fuel Filter	4.20	9.3	3.47	136.8	14.60	1272.2
Total	4.20	9.3	3.47	136.8	14.60	1272.2

Transport Canada - Accepted

AIRBUS HELICOPTERS CANADA LIMITED

10. PLACARDS AND MARKINGS

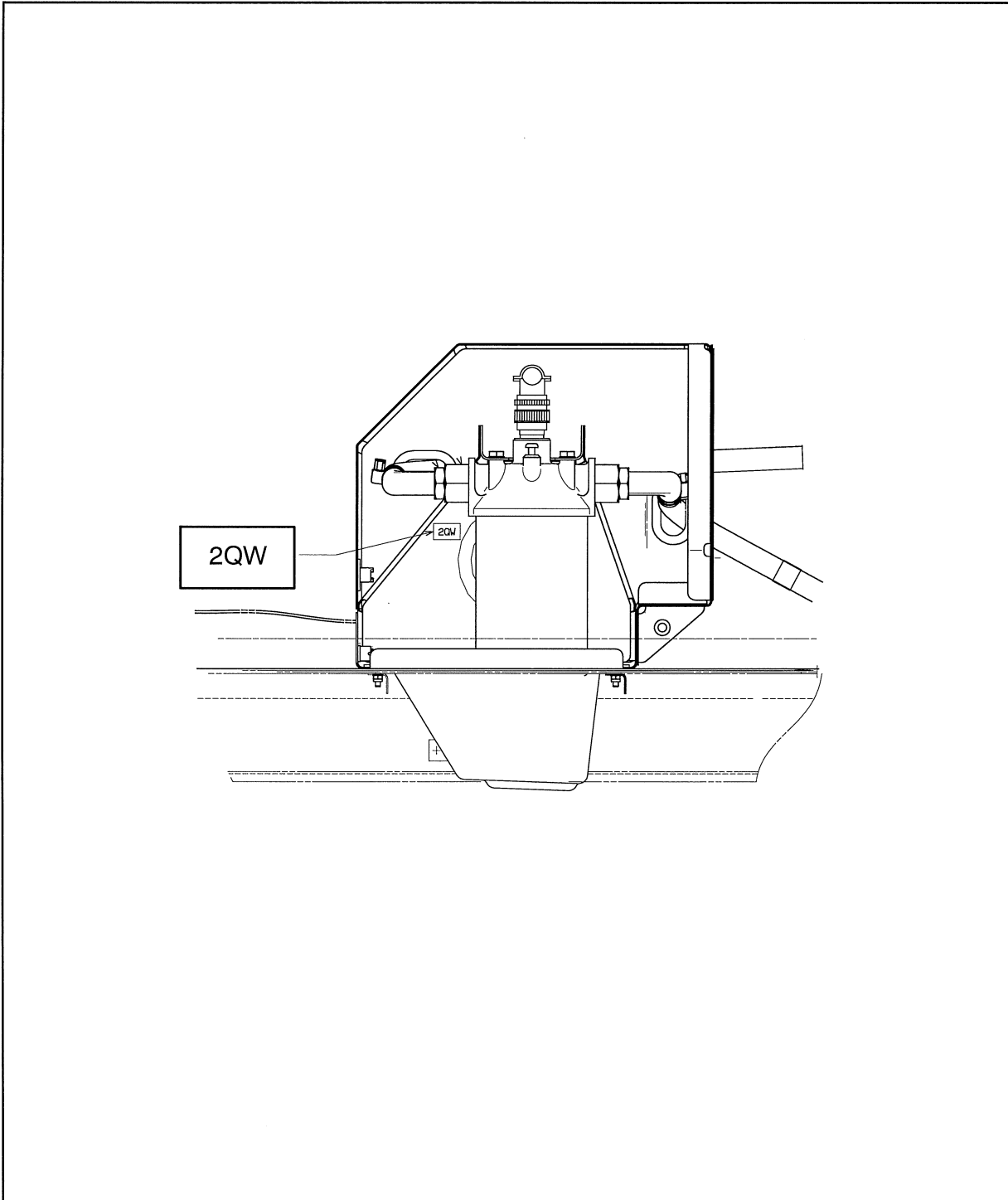

Figure 6 Typical label location on the Fuel Filter Support Assembly

Transport Canada - Accepted

AIRBUS HELICOPTERS CANADA LIMITED

10. PLACARDS AND MARKINGS

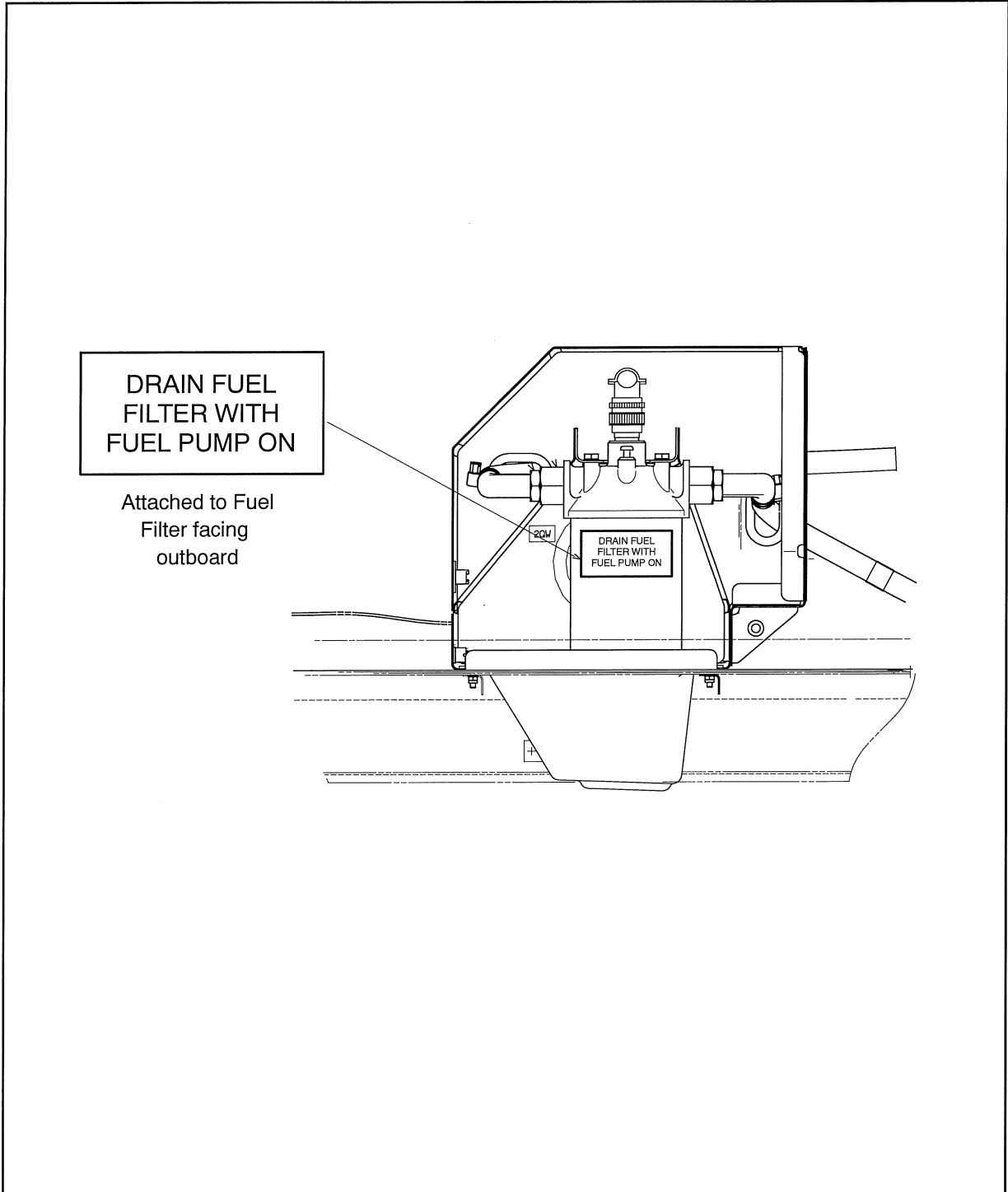

Figure 7 Typical label location on the Fuel Filter

Transport Canada - Accepted

AIRBUS HELICOPTERS CANADA LIMITED

10. PLACARDS AND MARKINGS (continued)

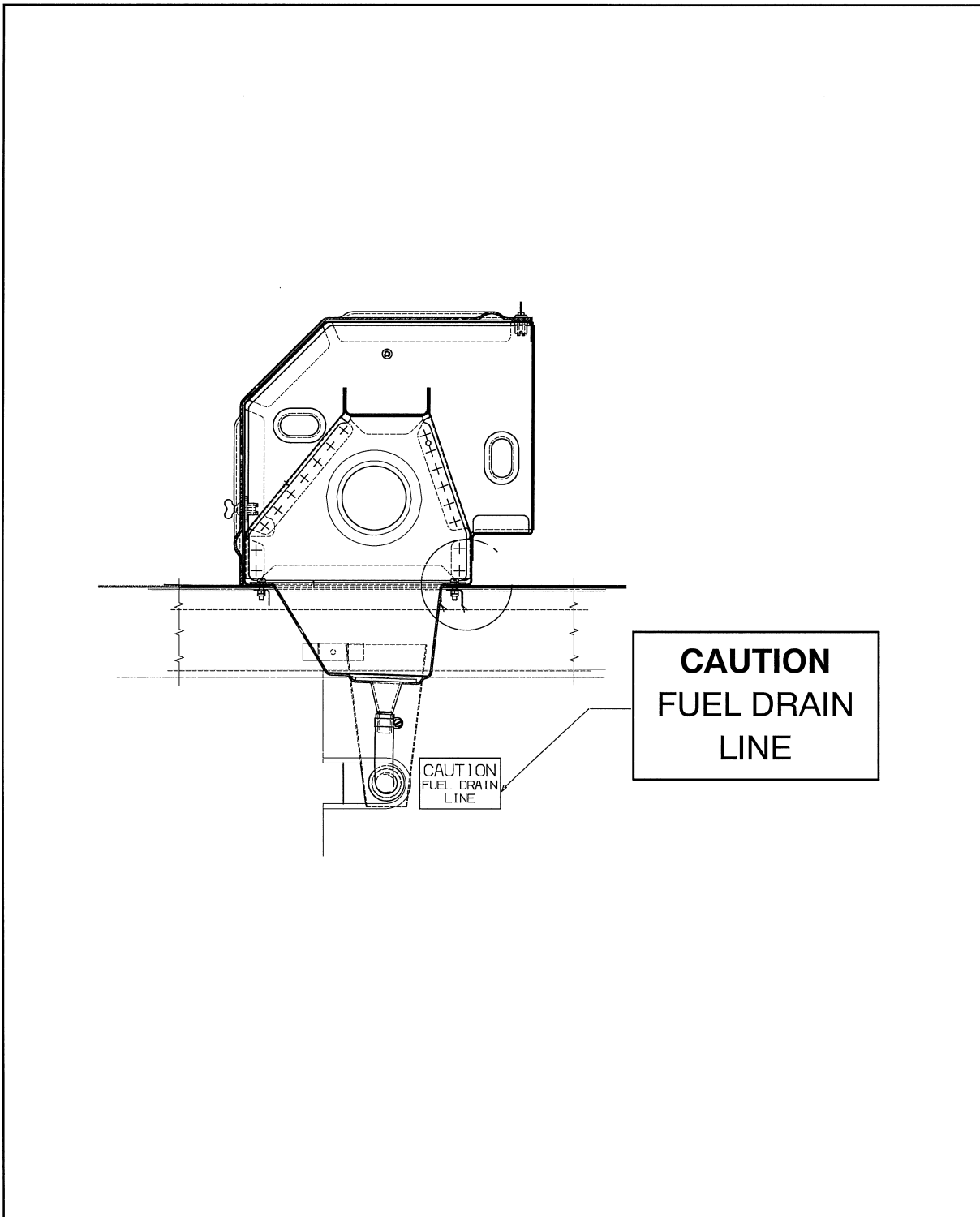

Figure 8 Typical label location in LH Cargo Compartment

Transport Canada - Accepted

10. PLACARDS AND MARKINGS (continued)

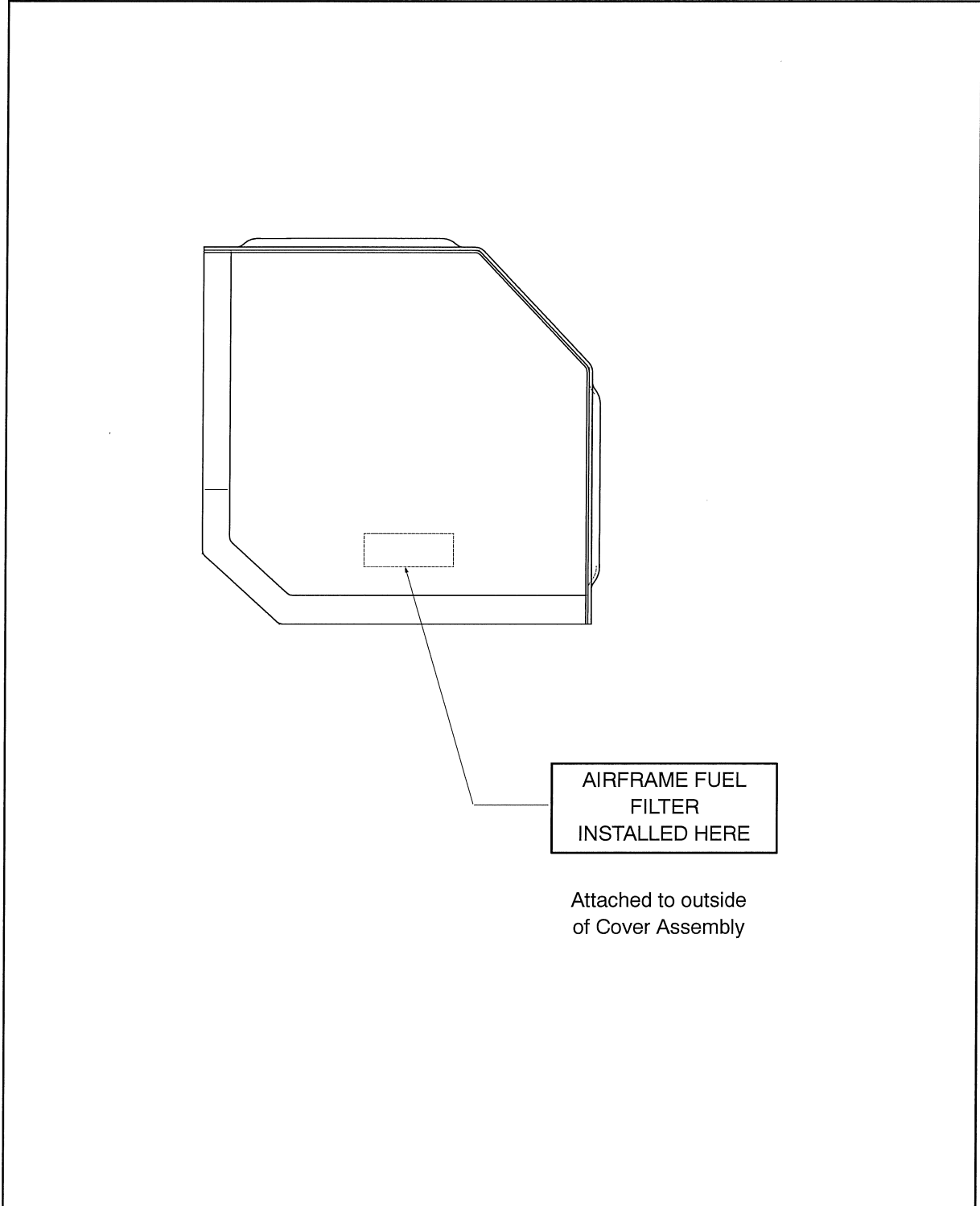

Figure 9 Typical label location on the Cover Assembly

Transport Canada - Accepted

10. PLACARDS AND MARKINGS (continued)

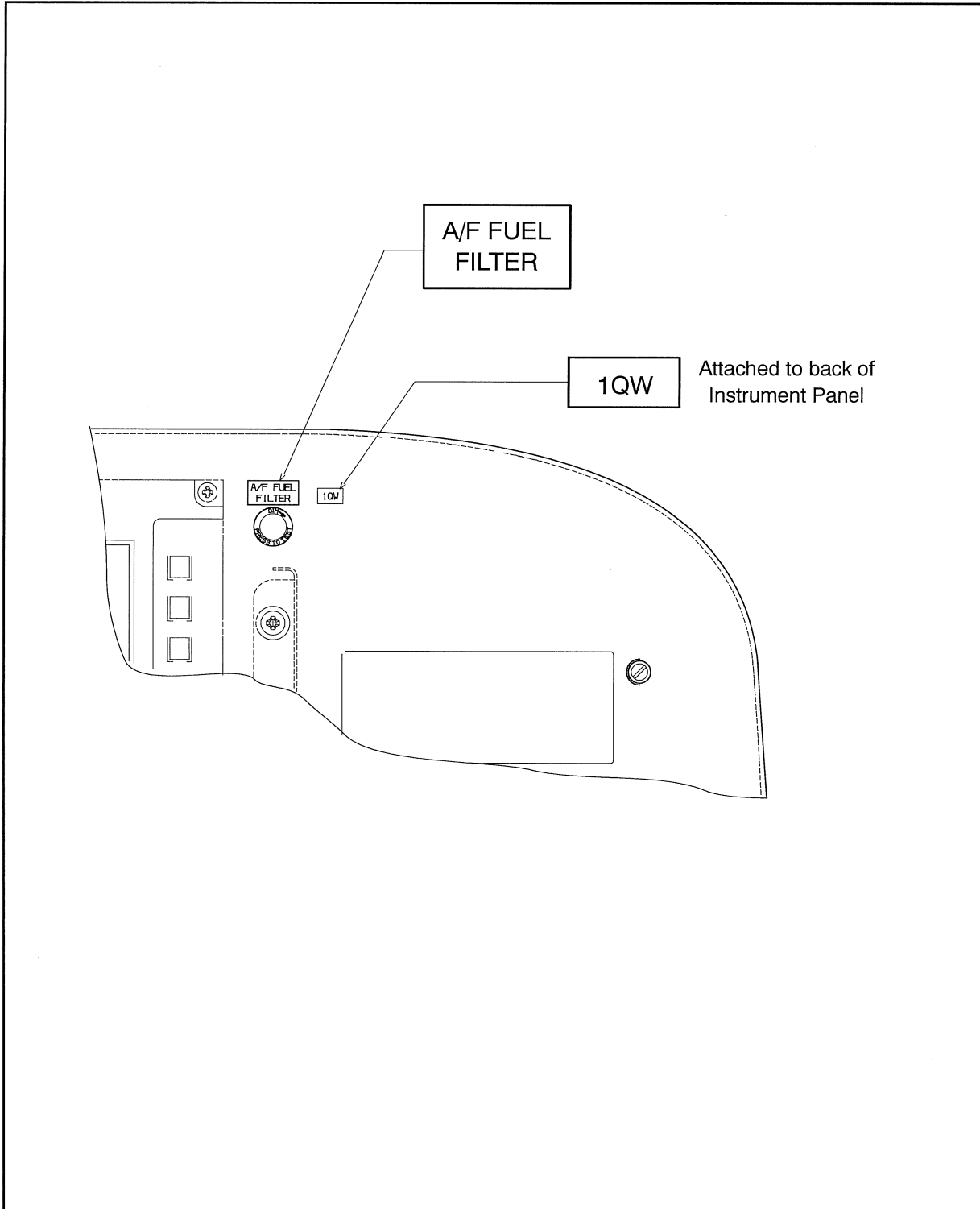

Figure 10 Typical label locations on the Instrument Panel

Transport Canada – Accepted

10. PLACARDS AND MARKINGS (continued)

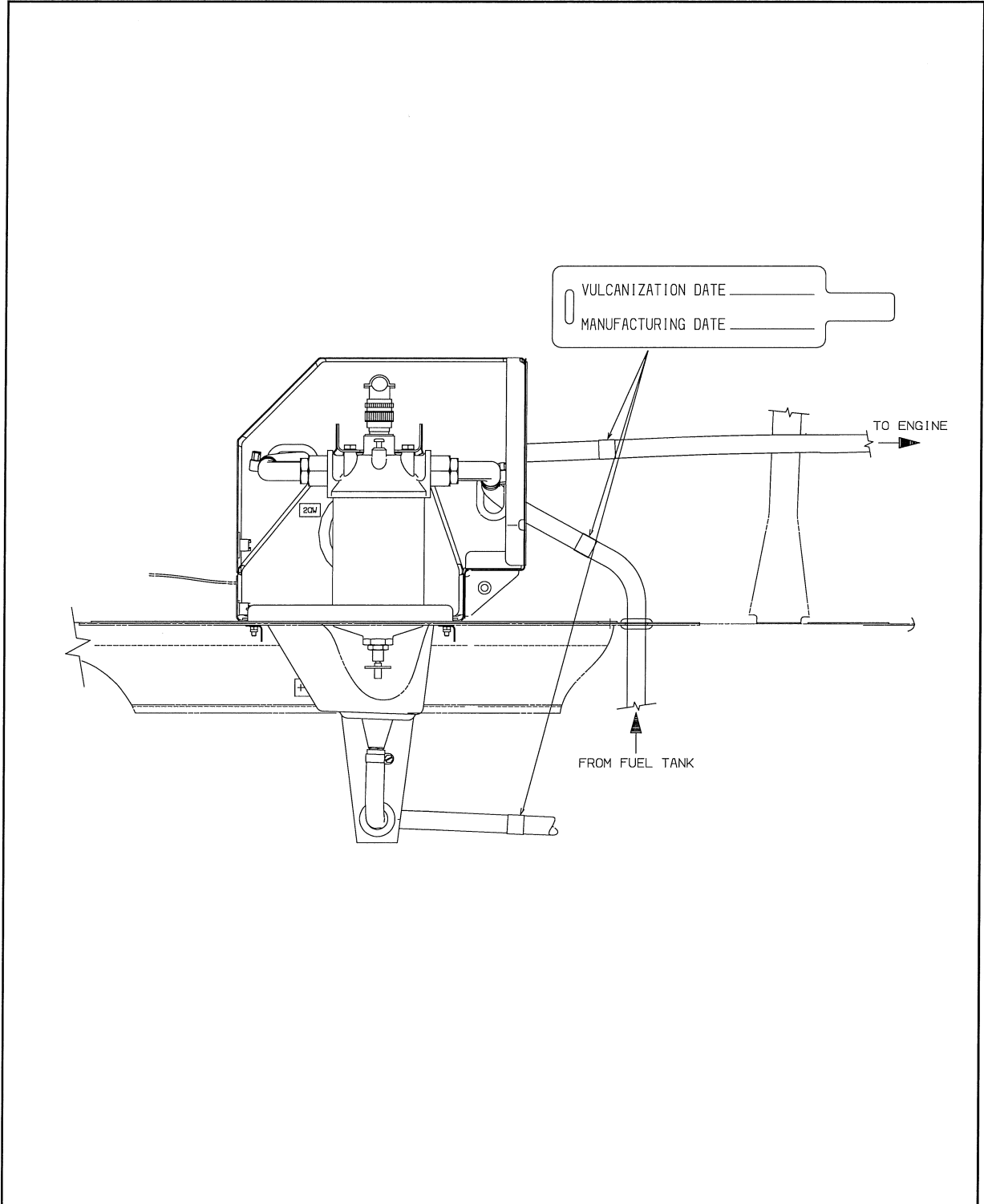

Figure 11 Typical location for identification tags on hoses

Transport Canada - Accepted



Operating & Design Specifications
Fuel Filter Assembly
Part No.: 1743640-01

Purolator Facet Inc.
8439 Triad Drive, Greensboro, NC 27409-9621
Phone: (336) 668-4444, Fax (336) 668-4452

Purolator Fuel Filter Assembly

Part No. 1743640-01

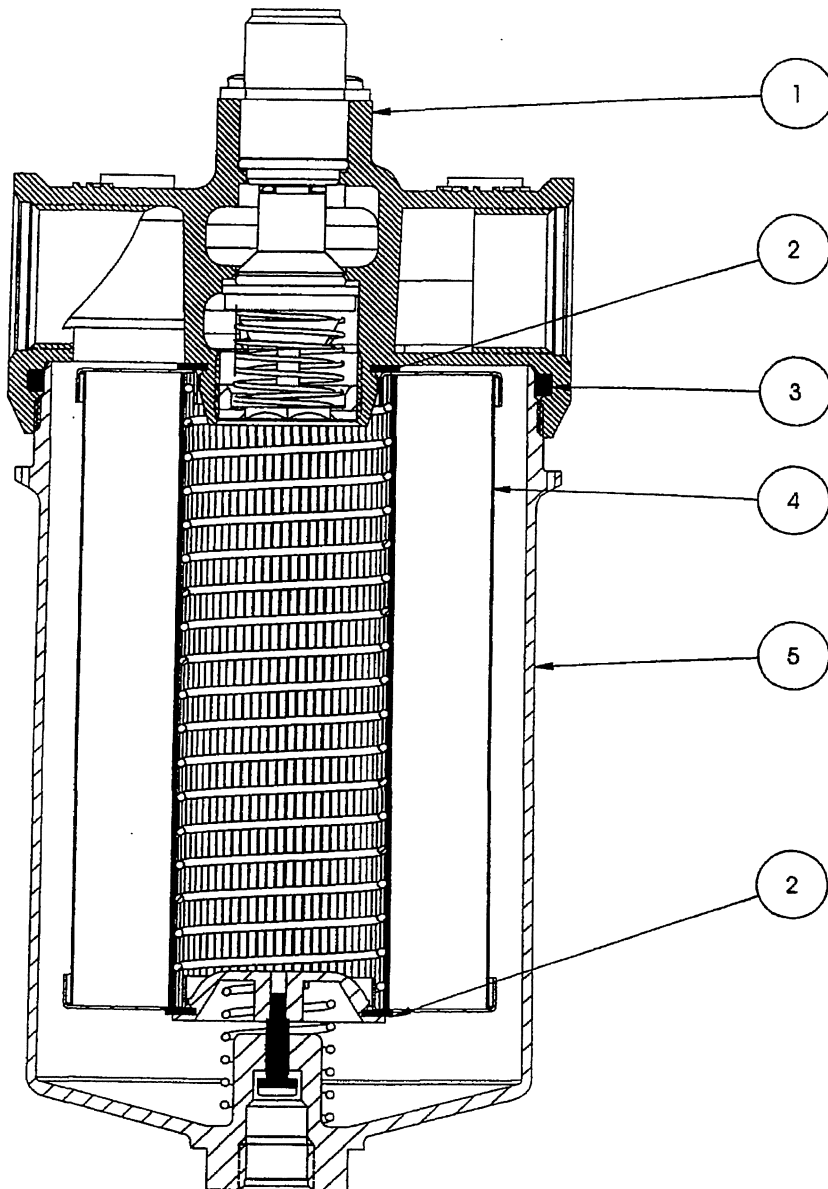

Replacement Parts for Filter Assembly Part No. 1743640-01

Item No.	Qty. Req.	Part No.	Description:
1.	1	1744990-01	Head Assembly
2.	2	1743629-01	Seal
3.	1	034921-01	O-Ring
4.	1	1743645-01	Element Assembly
5.	1	1745011	Bowl Assembly

NOTE: Purolator replacement element kit part no. 1743645-02 consists of items 2, 3 & 4

Operating Instructions:

Preflight Inspection Procedure Change:

1. Follow aircraft manufacturers recommended preflight instructions.
-

Scheduled Maintenance:

1. Fuel Filter Element Change:
 - A. Replace element at the intervals specified by the aircraft manufacturer.
 - B. Remove lockwire and unscrew filter bowl.
 - C. Remove used element.
 - D. Remove O-Ring and flat seals from filter head and inside of bottom of filter bowl.
 - E. Install new seals P/N: 1743629-01 on the nipple of the filter head and retainer in the filter bowl.
 - F. Install new filter element p/n: 1743645-01.
 - G. Install new O-Ring P/N: 034921-01 in the filter head.
 - H. Re-install filter bowl and torque to 130±20 inch pounds.
 - I. Secure filter head to filter bowl with lockwire.

**Purolator Fuel Filter Assembly
Part Number 1743640-01**

Design Specifications:

1. Filtration Rating: 10 Micrometres Nominal
2. Fluid: Mil-T 5624 Gr. JP-4, JP-5, ASTM-D-1655 Type A, A1 or B.
3. Temperature Range: -65°F to +160°F.
4. Bypass valve cracking Pressure: 3.75 PSID.
5. Microdelta® Differential Pressure Switch actuates at 0.875 PSID
7. Pressures: Operating: 60 PSI
 Proof: 90 PSI
 Burst: 180 PSI
8. Rated Flow: 0.5 GPM
9. Weight: 1.75 lbs. Max.

