



SUBJECT:

Required maintenance for the Airframe Fuel Filter (P/N 350-600024).

APPLICABILITY :

Aircraft with the subject modification embodied in accordance with TCCA STC. No. SH02-42 or any relevant foreign approvals.

THE INFORMATION CONTAINED IN THIS DOCUMENT SHALL BE TREATED AS THE PROPERTY OF EUROCOPTER CANADA LIMITED (ECL). THE RECIPIENT OF THIS DOCUMENT SHALL NOT DISCLOSE ANY INFORMATION CONTAINED HEREIN TO THIRD PARTIES WITHOUT THE WRITTEN PERMISSION OF ECL, AND SHALL NOT USE OR REPRODUCE THIS DOCUMENT IN WHOLE OR IN PART FOR ANY PURPOSE OTHER THAN ITS ORIGINALLY INTENDED PURPOSE, OR TO EVALUATE ITS CONTENTS.

	NAME AND SIGNATURE	DATE	COMPANY DEPARTMENT
PREPARED BY:	D. Kerr <i>D. Kerr</i>	17 Sept. 2012	ECL ENGINEERING
PREPARED BY:			
CHECKED BY:	C. Timmins <i>C. Timmins</i>	17 th Sep 2012	ECL ENGINEERING
CHECKED BY:	M. Merritt, for <i>[Signature]</i>	17 SEP 2012	ECL QUALITY ASSURANCE
APP'D / ACCEPTED (Civil A/W Authority)	(As per ICA Compliance Check Sheet) <i>C. Timmins</i>	20 th Dec 2012	TCCA
RELEASED BY:	R. Manson <i>R. Manson</i>	21 Dec 2012	ECL ENGINEERING



RECORD OF REVISIONS

Rev.	Pages at this Revision	Description, Reason Changed Pages	Prepared (name and date)	Checked (name and date)	App'd/Acc'd (Civil A/W Authority) (name and date)	Released (name and date)
0	1 through 12	Original Issue (Replaces MMS)	D. Kerr 29 July, 2004	C. Timmins 30 July, 2004	N/A	R. Manson 4 Aug., 2004
1	1 through 13	Changes to pages 1 to 13. General, and Troubleshooting revised as per TCCA request.	D. Kerr 8 September, 2004	C. Timmins 8 September, 2004	TCCA E. Cheung 8 September, 2004	R. Manson 8 September, 2004
2	1 through 21 A1 - A4	Format revised, Section 4 and 8 and Weight and Balance chart expanded. (Pages 3 to 6, 8 to 10, 12 to 21)	D. Kerr 21 July, 2006	C. Timmins 4 August, 2006	TCCA Floyd Eaves 9 August, 2006	R. Manson 9 August, 2006
3	1 through 24 A1 - A4	Replaced "boost" pump reference with "fuel" pump in Sec. 4. Added placard to outboard side of Fuel Filter. Wiring diagrams updated for latest basic a/c configuration. (Pages 3 to 5, 8, 9, 11 to 18, 20 to 24)	D. Kerr 28 March, 2008	C. Timmins 28 March, 2008	TCCA Floyd Eaves 7 April, 2008	R. Manson 10 April, 2008
4	1 through 29 A1 - A4	Revised format. Addition of 150 hr Press to Test. 100 flight hour increased to 150, 500 flight hours increased to 600 and 1000 flight hours increased to 1200 flight hours. Additional information added to Section 8. Weight and Balance Chart revised. (Pages 3 to 9, 11 to 23, 27)	See page 1.	See page 1.	See page 1.	See page 1.

NOTE: Revisions to this document will be distributed to operators of this equipment by the STC holder.

NOTE: Revised portions of affected pages are identified by a vertical black line in the margin adjacent to the change.

Transport Canada - Accepted



CONTENTS

SECTION	TITLE	PAGE
1	GENERAL	5
2	AIRWORTHINESS LIMITATIONS	10
3	CONTROL AND OPERATION	11
4	INSPECTION SCHEDULE AND MAINTENANCE ACTION	11
5	REPLACEMENT COMPONENTS AND REPAIR/OVERHAUL INFORMATION ..	15
6	TROUBLESHOOTING	15
7	SPECIAL TOOLING	18
8	REMOVAL AND REPLACEMENT	18
9	WEIGHT AND BALANCE	23
10	PLACARDS AND MARKINGS	24
APPENDIX A	PUROLATOR PRODUCTS COMPANY - Operating & Design Specifications (4 pages)	A1

FIGURES

FIGURE	TITLE	PAGE
1	General Layout	5
2	Airframe Fuel Filter Installation	6
3	Side view of Airframe Fuel Filter Installation	7
4	Deck Doubler and Base Installation Details	8
5	Airframe Fuel Filter, PRE & POST MOD: AMS 07-2797, Wiring Diagram	16
6	Airframe Fuel Filter, POST MOD: AMS 07-3274, Wiring Diagram	17
7	Identification Label on Fuel Filter Support Assembly	24
8	Placard on Fuel Filter	25
9	Placard in LH Baggage Compartment	26
10	Placard and Identification Label on Instrument Panel	27
11	Placards and Identification Label on alternative Instrument Panel	28
12	Identification Tags on hoses	29

Transport Canada - Accepted



TABLES

TABLE	TITLE	PAGE
1	Inspection Schedule and Maintenance Action Before the first flight of each day	11
2	Inspection Schedule and Maintenance Action Pre-Flight Check	11
3	Inspection Schedule and Maintenance Action Every 150 FH or 12 M (Margin: 15 FH or 36 D)	12
4	Inspection Schedule and Maintenance Action Every 600 FH or 24 M (Margin: 60 FH or 73 D)	13
5	Inspection Schedule and Maintenance Action Every 1200 FH or 48 M (Margin: 120 FH or 145 D)	13
6	Troubleshooting Guide	15

Transport Canada - Accepted

1. **GENERAL**

A. Introduction

The Airframe Fuel Filter enables operation of the helicopter at low temperatures without the use of anti-ice additives in the fuel. The filter is designed to collect ice particles. The filter contains a bypass valve and a bypass delta pressure switch. An annunciator light in the cockpit is provided to warn the pilot of an impending bypass of the filter. Refer to Figure 1.

The Airframe Fuel Filter consists of the following main components:

Fixed Provisions

- Fuel Filter Support Assembly
- Drain Sump Assembly
- Base
- Deck Doubler
- Drain Bracket

Detachable Provisions

- Fuel Filter
- Hoses

B. These Instructions for Continued Airworthiness are applicable to aircraft with the subject modification.

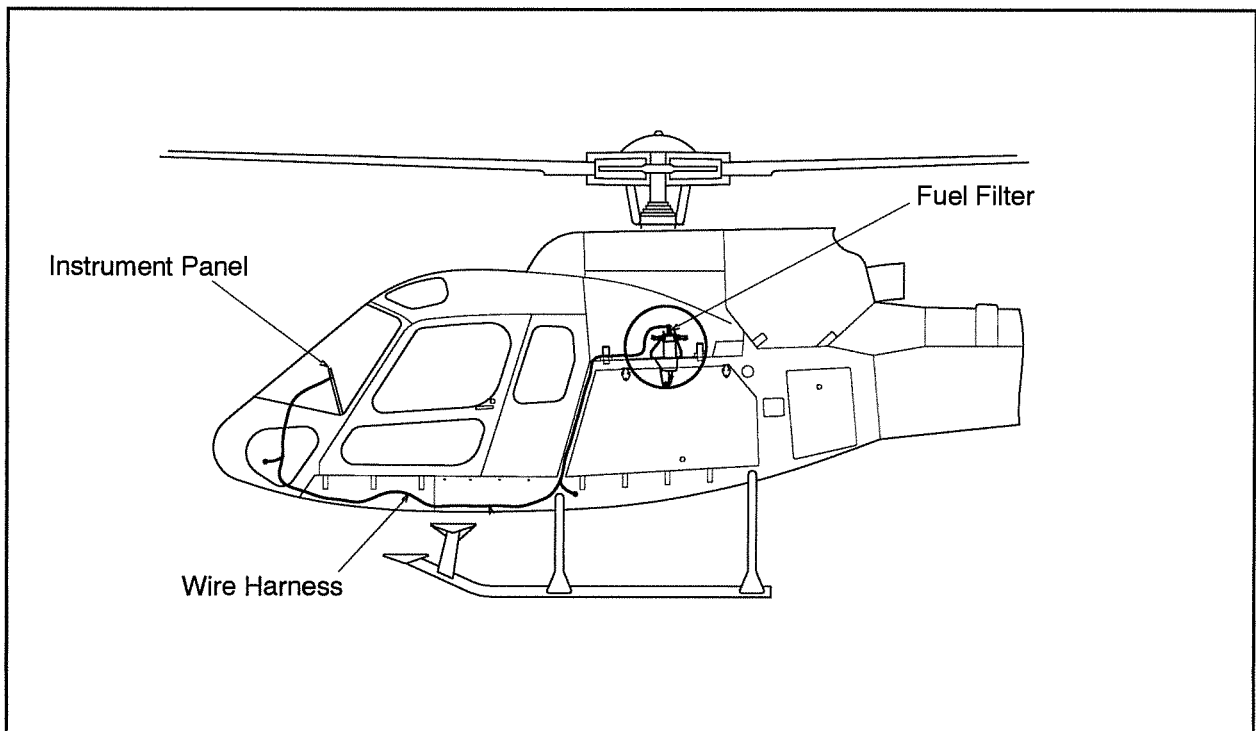

Figure 1 General Layout

Transport Canada - Accepted



Legend (for Figure 2)

Item	Description
1.	Deck Doubler
2.	Fuel Filter Support Assembly
3a.	Packing (P/N M83248/2-912)
3b.	Packing (P/N M83248/2-908)
4.	Elbow
5.	Hose End Cover
6.	Hose Clamp
7.	Nut
8.	Lockwire
9.	Reducer
10.	Screw
11.	Washer
12.	Hose (a and b)
13.	Drain Hose
14.	Grease (Mobil No. 28 / Aeroshell 22)
15.	Tywrap
16.	Fuel Filter
17.	Clamp
18.	Sealing Compound (P/N PR 1422 B2)
19.	Spacer

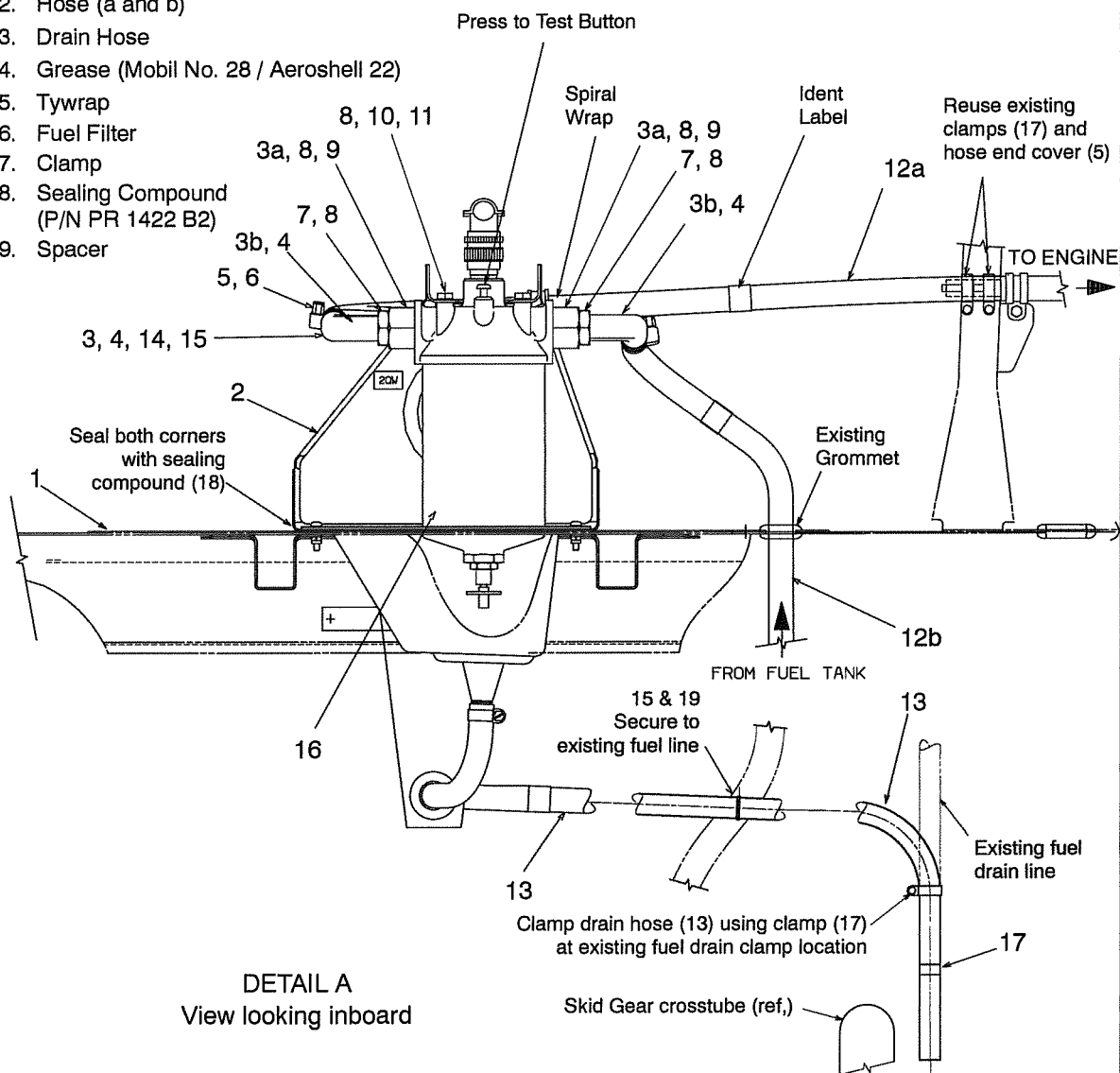
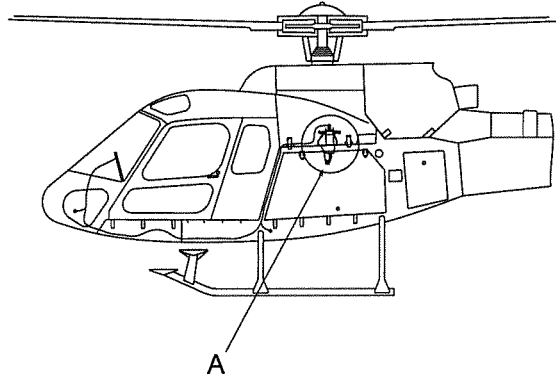

Figure 2 Airframe Fuel Filter Installation

Transport Canada - Accepted



Legend (for Figure 3)

Item	Description
1.	Base
2.	Fuel Filter
3.	Connector
4.	Backshell
5.	Drain Bracket
6.	Drain Sump Assembly
7.	Lockwire
8.	Packing (P/N MS29513-012)
9.	Drain Valve
10.	Drain Hose
11.	Screw
12.	Washer
13.	Nut
14.	Grommet
15.	Clamp
16.	Spacer
17.	Sealant (P/N PR 1422 B2)
18.	Hose Clamp

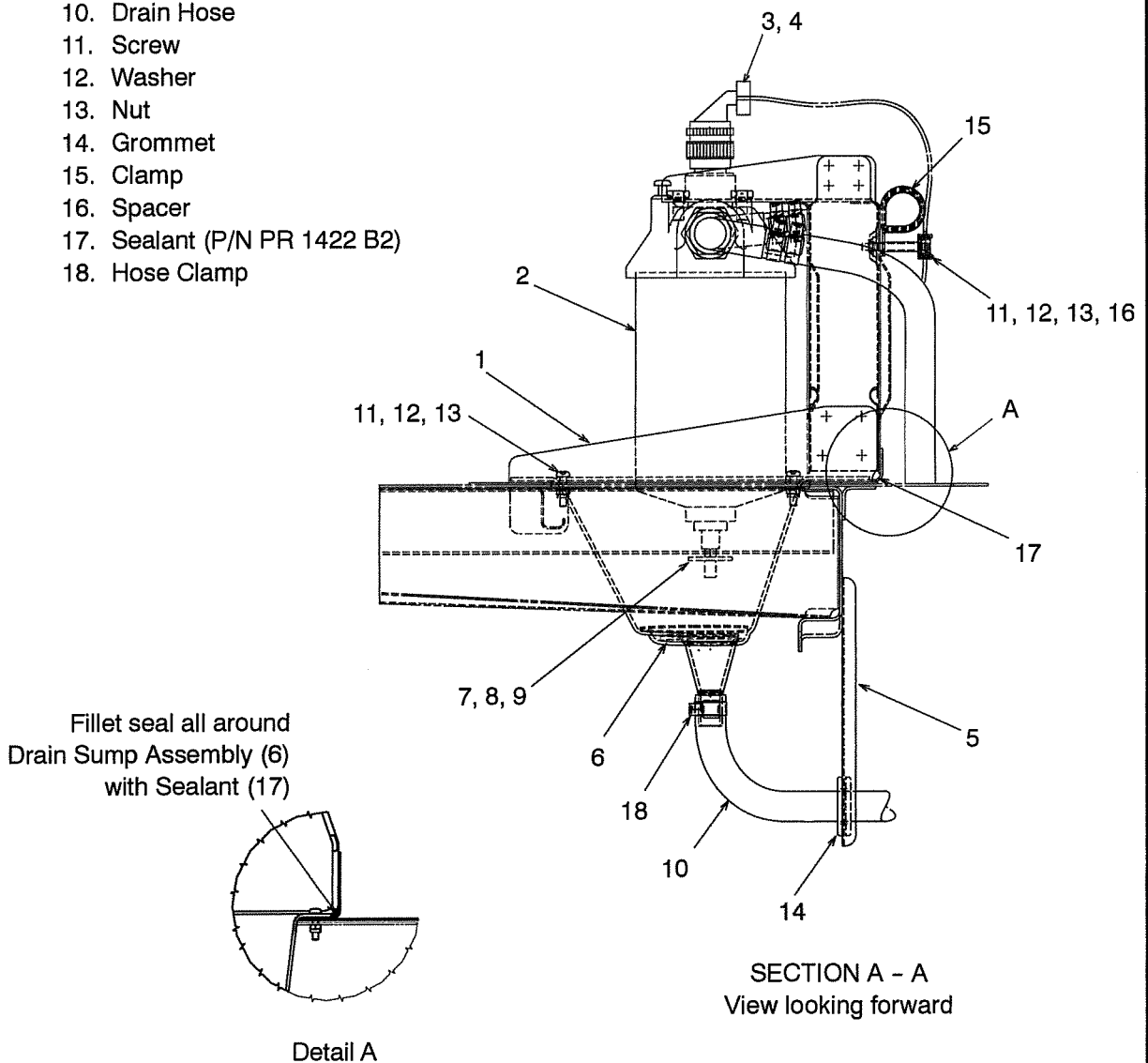
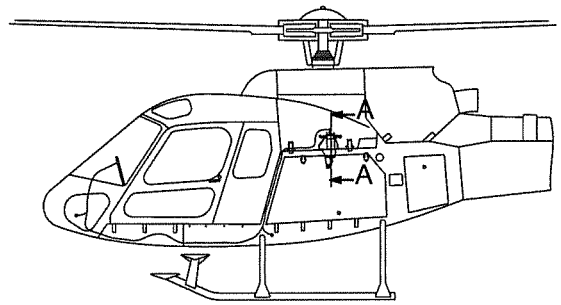

Figure 3 Side view of Airframe Fuel Filter Installation

Transport Canada - Accepted



Legend (for Figure 4)

Item	Description
1.	Deck Doubler
2.	Base
3.	Sealing Compound (PR 1422 B2)
4.	Rivets (P/N MS20470AD 4-5)
5.	Rivets (P/N MS20470AD 4-6)
6.	Rivets (P/N MS20470AD 4-7)
7.	Rivets (P/N MS20426AD 4-6)
8.	Rivets (P/N MS20426AD 4-7)
9.	Rivets (P/N MS20426AD 4-8)
10.	Rivets (P/N NAS9301B-4-02 or CR3213-4-02)
11.	Rivets (P/N NAS9301B-4-03 or CR3213-4-03)
12.	Rivets (P/N NAS9302B-4-02 or CR3212-4-02)
13.	Rivets (P/N NAS9307M-4-03 or CR3523-4-03)
14.	Rivets (P/N NAS9307M-4-05 or CR3523-4-05)

Through deck doubler (1)
and airframe only)

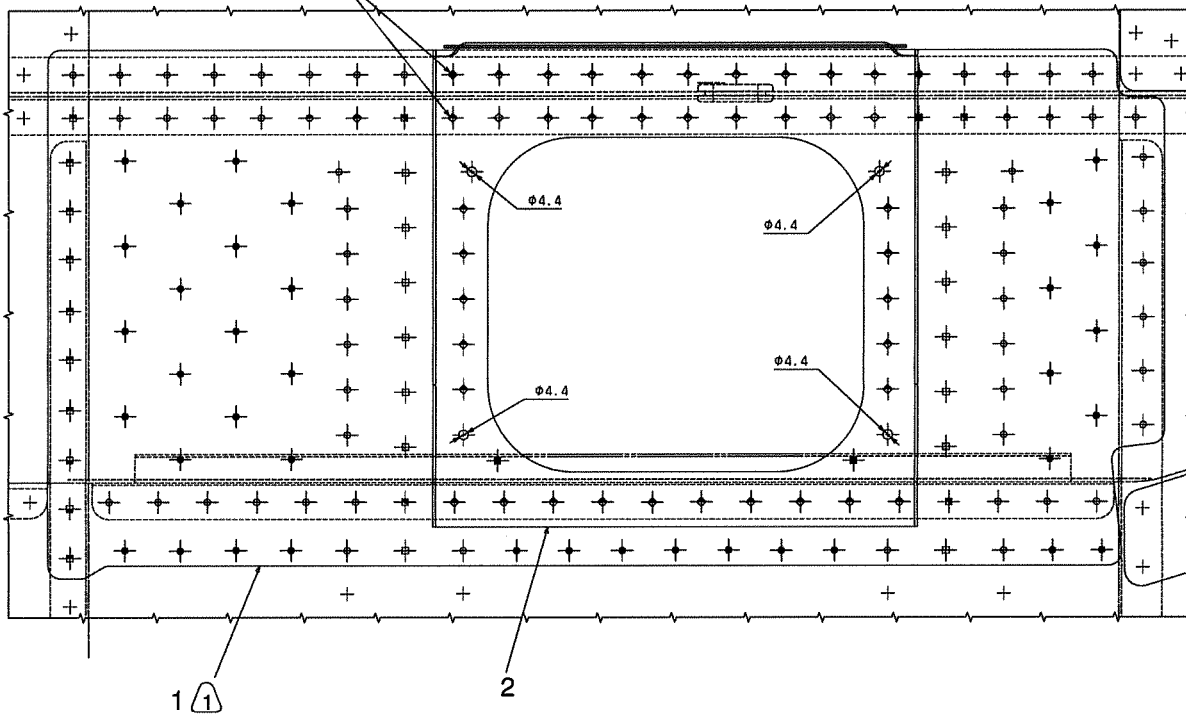

View looking down on Transmission Deck
Drain Sump Assembly and Fuel Filter not shown

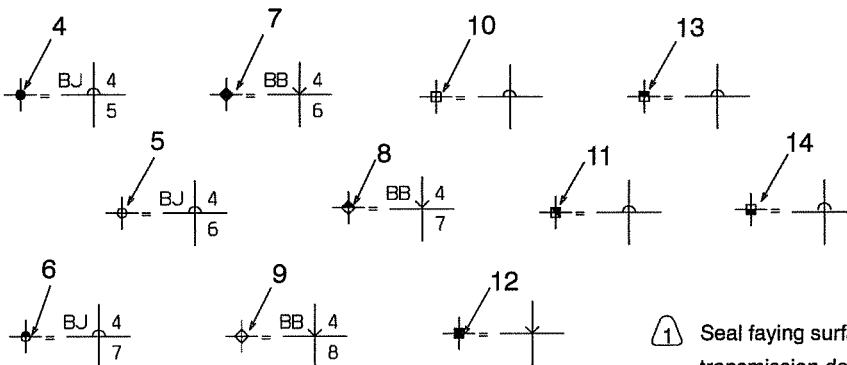

Rivets for this view shown above

① Seal faying surface and fillet seal edge of doubler (1) to transmission deck using sealant (3).

NOTES:

Figure 4 Deck Doubler and Base Installation Details

Transport Canada - Accepted

C. REFERENCES

DOCUMENT	DOCUMENT TITLE
AC-43.13 - 1B	Advisory Circular, Acceptable Methods, Techniques and Practices - Aircraft Inspection and Repair
AMM (AS 350 B2/B3 only)	Aircraft Maintenance Manual
MTC	Standard Practices Manual
IP-ECL-111	Installation Procedure
Manual Number 1743640-01	"Operating and Design Specifications", Fuel Filter Assembly, Purolator Products Company

D. ABBREVIATIONS AND DEFINITIONS

ABBREVIATION	DEFINITION
A/F	Airframe
D	Days
EC	Eurocopter (France)
ECL	Eurocopter Canada Limited
FH	Flight Hours
hrs	hours
LHS	Left-Hand Side
M	Months
Max.	Maximum
No.	Number
P/N	Part Number
Qty.	Quantity
RHS	Right-Hand Side

E. UNITS OF MEASUREMENT

ABBREVIATION / SYMBOL	UNIT OF MEASUREMENT
F	Fahrenheit
GPM	Gallons per Minute
in	inch
kg	kilogram
lb	pound
PSI	Pounds per Square Inch
PSID	Pounds per Square Inch Differential
®	Registered Trademark
°	degree
±	plus or minus

Transport Canada - Accepted

2. AIRWORTHINESS LIMITATIONS

The Airworthiness Limitations section is approved by the Minister and specifies maintenance required by any applicable airworthiness or operating rule unless an alternative program has been approved by the Minister.

No airworthiness limitations associated with this installation.

Transport Canada - Approved

3. CONTROL AND OPERATION

Control and operation of the aircraft remains unchanged.

4. INSPECTION SCHEDULE AND MAINTENANCE ACTION

For additional information on operation and maintenance, refer to the "Purolator" Operating and Design Specifications, Fuel Filter Assembly P/N: 1743640-01, located in Appendix A.

NOTE: Use torque per EC, MTC, Volume 2, Chapter 20.02.05.404, unless otherwise specified.

4.1. INSPECTION SCHEDULE

4.1.1. Before the first flight of each day:

ITEM	INSPECTION OR MAINTENANCE WORK	CORRECTIVE ACTION
A	<ul style="list-style-type: none"> - Turn on fuel pump and check Airframe Fuel Filter for: <ul style="list-style-type: none"> a. water in fuel b. air in fuel line c. leaks in the fuel filter and the drain valve 	<ul style="list-style-type: none"> a. Open drain valve, purge any water from the system. b. Hold drain valve open until all air is purged. c. No leaks with fuel pump on. Check valve seating, replace packing, item 8, in Figure 3 as necessary (P/N MS29513-012)
B	<ul style="list-style-type: none"> - Turn off fuel pump and check Airframe Fuel Filter for: <ul style="list-style-type: none"> a. debris in fuel drain, below the filter and/or on the transmission deck b. secure mounting and connection of filter and hoses c. condition of electrical connector and wiring 	<ul style="list-style-type: none"> a. Remove and clean as necessary. b. Secure as required. c. If cracks, fraying or burns are found, contact ECL for replacement parts.

Table 1 Inspection Schedule and Maintenance Action
Before the first flight of each day

4.1.2. Pre-Flight Check:

ITEM	INSPECTION OR MAINTENANCE WORK	CORRECTIVE ACTION
A	<ul style="list-style-type: none"> - Push A/F FUEL FILTER by-pass "Press to Test" caution light: <ul style="list-style-type: none"> a. apply power to 4 Alpha Warning Panel (Master/Battery switch to ON) and push Press to Test A/F FUEL FILTER annunciator - lamp must illuminate. 	<ul style="list-style-type: none"> a. If lamp fails to illuminate, refer to Chapter 6, Troubleshooting, item 1, in this document

Table 2 Inspection Schedule and Maintenance Action
Pre-Flight Check

Transport Canada - Accepted



4. **INSPECTION SCHEDULE AND MAINTENANCE ACTION** (continued)

4.1.3. Every 150 FH or 12 M (Margin: 15 FH or 36 D) to coincide with the 150 FH or 12 M helicopter inspection, whichever occurs first:

ITEM	INSPECTION OR MAINTENANCE WORK	CORRECTIVE ACTION
A	<ul style="list-style-type: none"> - Push the Press to Test Button on the Fuel Filter, shown in Figure 3: a. Push the Press to Test Button on the Fuel Filter, the A/F FUEL FILTER annunciator-lamp must illuminate. 	<ul style="list-style-type: none"> a. If lamp fails to illuminate, refer to Chapter 6, Troubleshooting, item 2, in this document.
B	<ul style="list-style-type: none"> - Check doubler, item 1, and fuel filter support assembly, item 2, in Figure 2 for: a. cracks or corrosion 	<ul style="list-style-type: none"> a. No cracks or corrosion are allowed. If cracks or deformation are found, contact ECL for replacement parts.
C	<ul style="list-style-type: none"> - Check hoses, item 12, and drain hose, item 13, in Figure 2 for: a. leaks b. cracking 	<ul style="list-style-type: none"> a. If leaks are found, contact ECL for replacement parts. b. No cracking is allowed. If cracking is found, contact ECL for replacement parts.
D	<ul style="list-style-type: none"> - Check base, item 1, and drain bracket, item 5, in Figure 3 for: a. cracks or corrosion 	<ul style="list-style-type: none"> a. No cracks or corrosion are allowed. If cracks or deformation are found, contact ECL for replacement parts.
E	<ul style="list-style-type: none"> - Check drain sump assembly, item 6, in Figure 3 for: a. cracks or deformation 	<ul style="list-style-type: none"> a. No cracks or deformation are allowed. If cracks or deformation are found, contact ECL for replacement parts.
F	<ul style="list-style-type: none"> - Check placards and markings in Figures 6, 7, 8, 9, 10 and 11 (Section 10) for: a. legibility b. secure mounting 	<ul style="list-style-type: none"> a. If placards and markings have become illegible, contact ECL for replacement parts. b. Secure, reattach placards as required.

Table 3 Inspection Schedule and Maintenance Action
Every 150 FH or 12 M to coincide with the 150 FH or 12 M helicopter inspection,
whichever occurs first

Transport Canada - Accepted



4. INSPECTION SCHEDULE AND MAINTENANCE ACTION (continued)

4.1.4. Every 600 FH or 24 M, (Margin: 60 FH or 73 D) to coincide with the 600 FH or 24 M helicopter inspection, whichever occurs first:

ITEM	INSPECTION OR MAINTENANCE WORK	CORRECTIVE ACTION
A	Perform Operational Test - Switch and Bypass Valve	See Operational Test Instructions given in Section 4.1.6.

Table 4 Inspection Schedule and Maintenance Action
Every 600 FH or 24 M to coincide with the 600 FH or 24 M helicopter inspection,
whichever occurs first

4.1.5. Every 1200 FH or 48 M (Margin: 120 FH or 145 D) to coincide with the 1200 FH or 48 M helicopter inspection, whichever occurs first:

ITEM	INSPECTION OR MAINTENANCE WORK	CORRECTIVE ACTION
A	Replace Fuel Filter Element	See Replacement Instructions given in Section 4.1.7.

Table 5 Inspection Schedule and Maintenance Action
Every 1200 FH or 48 M to coincide with the 1200 FH or 48 M helicopter inspection,
whichever occurs first

Transport Canada - Accepted

4. INSPECTION SCHEDULE AND MAINTENANCE ACTION (continued)

NOTE: Filter Element can be replaced more frequently if operational elements dictate.

NOTE: Should the A/F FUEL FILTER annunciator light illuminate, the fuel filter element must be replaced.



A partially blocked filter element will cause a differential pressure switch in the head assembly to close and the A/F FUEL FILTER annunciator to illuminate. If the filter element becomes fully blocked a differential pressure activated valve will permit fuel to bypass the filter.

4.1.6 Operational Test - Fuel Filter Switch and Bypass Valve

- a. Observe FUEL SYSTEM General Instructions. Refer to AMM 28-00-00, 01.
- b. Apply power to annunciator panel. Press differential pressure switch Test Button, on the top of the fuel filter, A/F FUEL FILTER annunciator must illuminate.
- c. Replace filter element with clean dummy element.
- d. Disconnect outlet hose of optional fuel filter from inlet of shut-off valve and place hose in a suitable container to collect fuel.
- e. Turn on fuel pump(s).
- f. The A/F FUEL FILTER annunciator should illuminate, and fuel should freely flow from outlet hose of fuel filter into the container.
- g. When test is successfully completed, remove dummy element and install filter element. Follow instructions given in Chapter 4, Replacement - Fuel Filter Element.
- h. Operate fuel pump and open fuel filter bowl drain until all air is purged.
- i. Reconnect outlet hose of optional fuel filter to inlet of shut-off valve.

4.1.7 Replacement - Fuel Filter Element

- a. Observe FUEL SYSTEM General Instructions. Refer to AMM 28-00-00, 01.
- b. Drain fuel from filter bowl into a container.
- c. Refer to Appendix "Operating Instructions" Purolator Products Company for Fuel Filter Element Change.
- d. Operate fuel pump and open fuel filter bowl drain until all air is purged.

NOTE: The Purolator Filter Assembly (Part No. 1743640-01) Replacement Element Kit is also available, Purolator Products Company Part No. 1743645.02. This kit consists of a Seal, an O-ring and an Element Assembly.

Transport Canada - Accepted

5. REPLACEMENT COMPONENTS AND REPAIR/OVERHAUL INFORMATION

Replacement components and repair/overhaul information required for this installation.

6. TROUBLESHOOTING

There are no unique characteristics which require special troubleshooting techniques: standard techniques are adequate.

For electrical system troubleshooting, refer to Figures 4 and 5, Wiring Diagram.

No.	Trouble Symptom	Probable Cause	Corrective Action
1	A/F FUEL FILTER lamp does not illuminate during Daily Preflight Inspection	Bulb burnt out.	Replace bulb, P/N MS25237-327
2	A/F FUEL FILTER lamp does not illuminate during either the 150 flight hr check or the Operational Test (600 flight hr check)	Break or short in annunciator circuit	Perform circuit continuity check and repair/replace wiring as applicable in accordance with AC43.13-1B, Chapter 11, Section 1.
		Fuel Filter Head Assembly defective	Replace Head Assembly, refer to the Purolator Documentation.
3	A/F FUEL FILTER illuminates during operations.	Excessive contamination in fuel supply.	Check quality of fuel supply.
		Filter is blocked prematurely.	Replace filter element.
		Short in annunciator circuit.	Perform circuit continuity check and repair/replace wiring as applicable in accordance with AC43.13-1B, Chapter 11, Section 1.

Table 6 Troubleshooting Guide

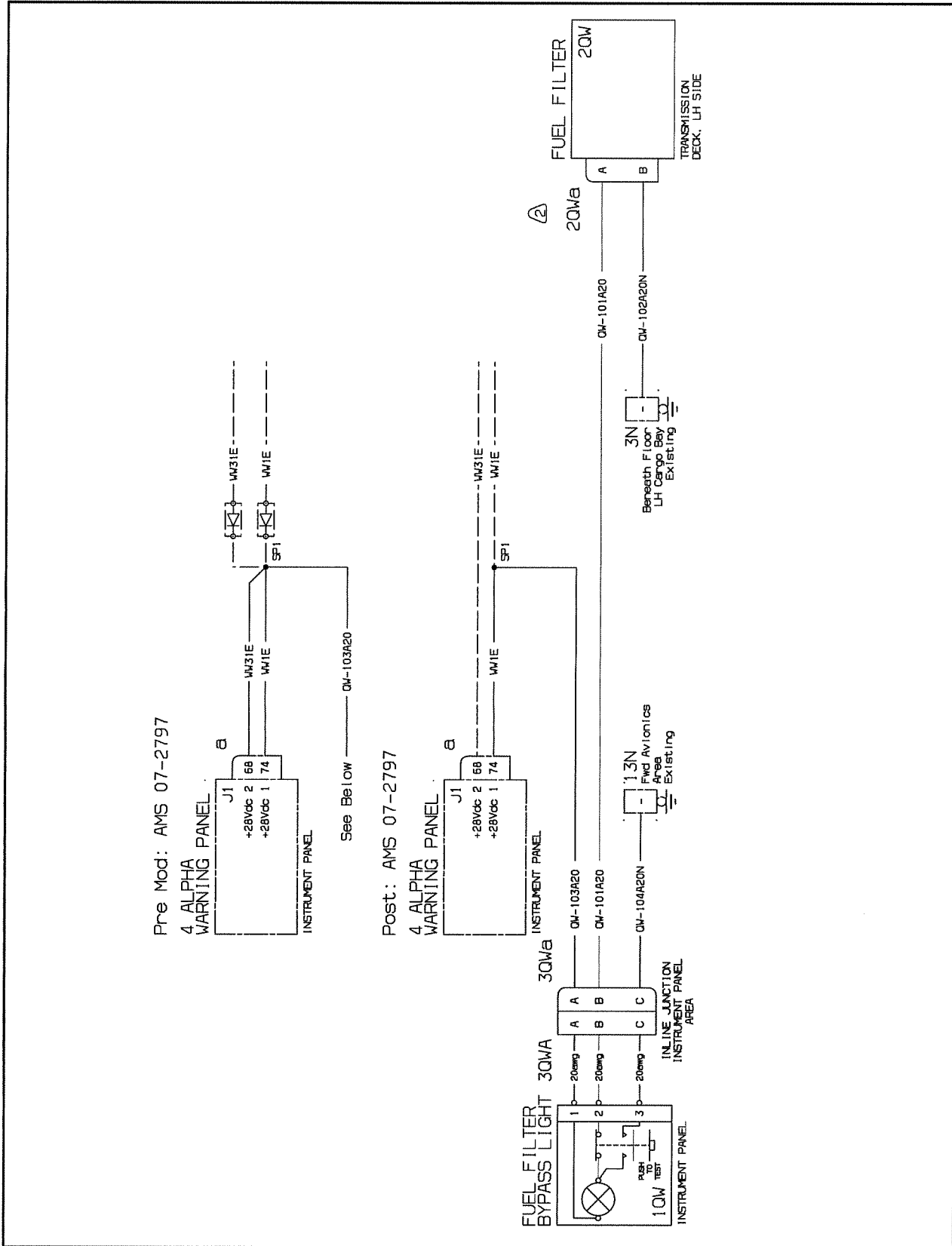

Figure 5 Airframe Fuel Filter, PRE & POST MOD: AMD 07-2797, Wiring Diagram

Transport Canada Accepted

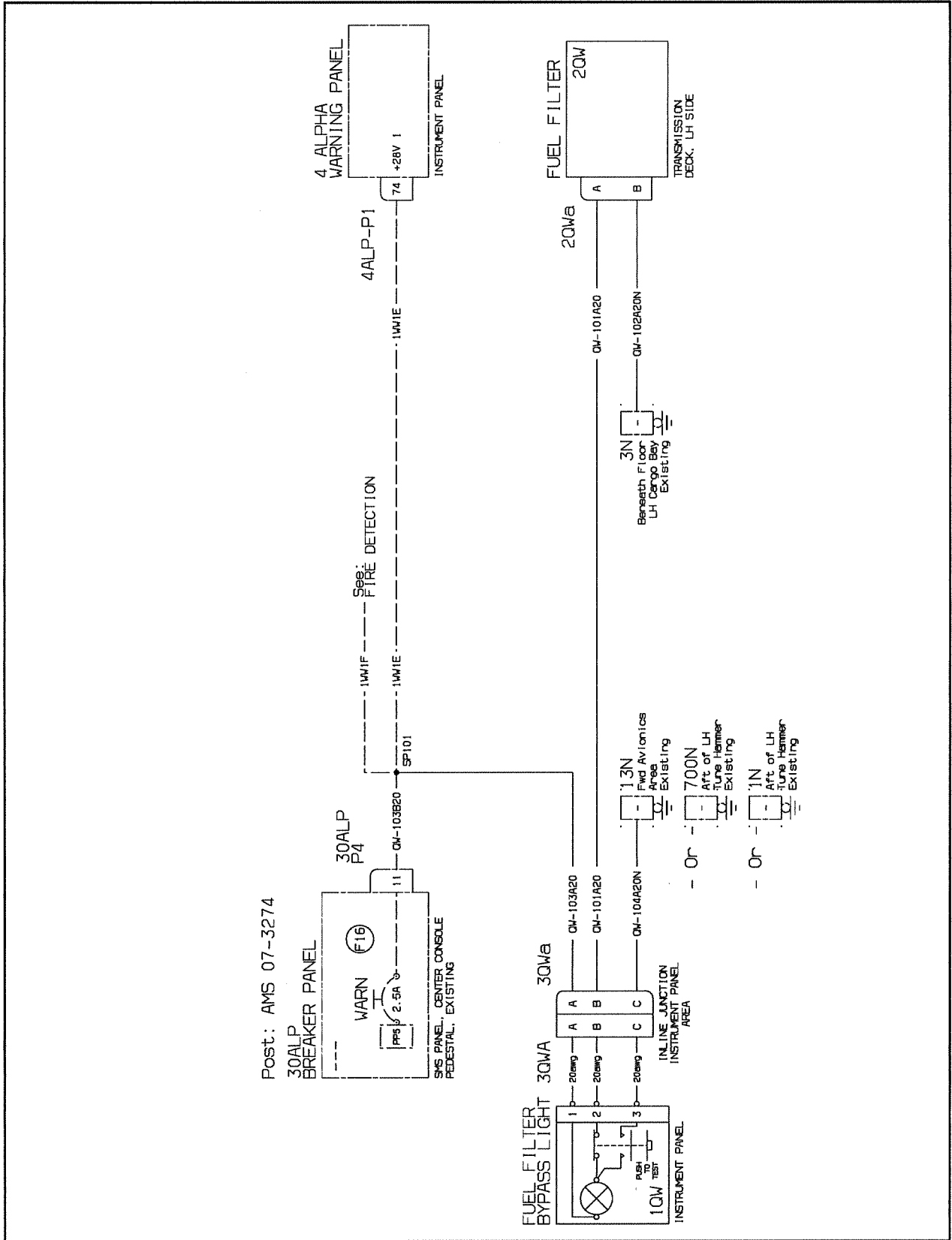

Figure 6 Airframe Fuel Filter, POST MOD: AMS 07-3274, Wiring Diagram

Transport Canada Accepted

7. SPECIAL TOOLING

No special test equipment or tools are required. Standard tools are adequate.

8. REMOVAL AND REPLACEMENT

Proceed as follows if fuel filter needs to be removed.

PRELIMINARIES

- Read General Safety Instruction - Electrical Power Supply, refer to AS 350 B2/B3 AMM, Chapter 24-00-00, 3-1.
- Read Electrical Power Supply on the Ground, refer to AS 350 B2/B3 AMM, Chapter 24-00-00, 2-1.
- Disconnect the external power unit and battery, refer to Removal/Installation, AS 350 B2/B3 AMM, Chapter 24-33-00, 4-1.
- Observe General Safety Instructions - Fuel System, refer to AS 350 B2/B3 AMM, Chapter 28-00-00, 3-1.
- Observe General Repair Instructions Unriveting Principle, refer to MTC, Chapter 20-03-01-102.
- Open the left MGB and engine cowling.

A. REMOVAL

1) Hoses (Refer to Figures 2 and 3)

- a) Disconnect hose clamps (6) and spiral wrap if applicable and remove hose (12a or b). Close hose end cover (5). Retain hose clamps (6), hose end covers (5) and spiral wrap for reinstallation. Refer to Figure 2.
- b) Remove packing (3b) from elbow (4) and discard packing. Refer to Figure 2.

NOTE: If hose (12a or b) are not being replaced, position hose out of work area and close hose end covers (5). Refer to Figure 2.

NOTE: Reuse clamps, hose end covers and spiral wrap from existing hose.

2) Fuel Filter (Refer to Figures 2 and 3)

- a) Disconnect hoses on either side of the Fuel Filter. Follow instructions given above.
- b) Disconnect connector (3) and backshell (4) from fuel filter (2) and position wire out of working area. Refer to Figure 3.
- c) Remove lockwire (8), screws (10, 3 places), and washers (11, 3 places) that secure the fuel filter (16) to top of fuel filter support assembly (2). Refer to Figure 2.
- d) Remove fuel filter (16). Retain screws (10) and washers (11) for reinstallation. Refer to Figure 2.

3) FUEL FILTER WIRING

- a) Remove damaged Airframe Fuel Filter wire or component.

8. REMOVAL AND REPLACEMENT (continued)

A. REMOVAL (continued)

- 4) Drain Sump Assembly, Drain Bracket, Fuel Filter Support, Base Fuel Filter Support Assembly & Deck Doubler (Refer to Figures 2 and 3)
 - a) Remove the Fuel Filter. Follow instructions given above.
 - b) To remove the drain sump assembly (6) disconnect the hose clamp (18) and remove hose (10). Remove screws (11, 4 places), washers (12, 8 places) and nuts (13, 4 places). Refer to Figure 3.
 - c) Remove drain bracket (5) from rear bulk head and discard. Retain grommet (14) for reinstallation. Refer to Figure 3.
 - d) Drill out rivets securing the base (2) to the deck doubler. If replacing base (2) or fuel filter support assembly, drill out rivets and discard damaged part. Refer to Figures 2 and 4.
 - e) Drill out rivets securing the deck doubler to the transmission deck. Refer to Figure 4.

Transport Canada - Accepted

8. REMOVAL AND REPLACEMENT

B. REPLACEMENT

NOTE Use torque per EC, MTC, Volume 2, Chapter 20.02.05.404, unless otherwise specified.

Safetying with Lockwire - refer to Safetying with Lockwire - MTC, Chapter 20-02-06-402.

Sealing compound PR-1422 B2 - refer to General methods for applying sealing compounds - MTC, Chapter 20.05.01.102 and Application of PR 1422 B sealant - MTC, Chapter 20-05-01-206.

Observe General Safety Instructions - Fuel System, refer to AS 350 B2/B3 AMM, Chapter 28-00-00, 3-1.

Electrical Bonding - refer to Electrical Bonding - General, MTC, Chapter 20.02.07.101.

1) Drain Bracket, Deck Doubler, Base & Drain Sump Assembly (Refer to Figures 2 and 3)

- a) If replacing drain bracket (5), position drain bracket (5) onto rear bulkhead and secure using rivets (5 places [MS20470AD]) and reinstall grommet (14). Refer to Figure 3.
- b) Position new deck doubler (1) onto transmission deck. Align opening and existing rivet holes. Temporarily secure to the transmission deck and match drill existing holes from the transmission deck into the deck doubler (1). Open 4 holes to 4.4 mm diameter as shown in Figure 4.
- c) Position base (2) onto deck doubler (1). If replacing base, match drill holes from deck doubler (1) into base (2) as shown in Figure 4.
- d) If replacing drain sump assembly (3), Temporarily position the drain sump assembly (3) onto base (2) and match drill 4 pilot holes from base (2) into drain sump. Refer to Figure 3.
- e) Remove drain sump assembly (3), base (2) and deck doubler (1) from transmission deck and deburr all newly drilled holes.
- f) Reposition deck doubler (1) onto transmission deck and secure into place using rivets. Follow rivet chart shown in Figure 4.
- g) Position base (2) onto deck doubler (1) and seal faying surfaces with sealant (3) and secure into place using rivets. Follow rivet chart shown in Figure 4. Refer to General Sealing Procedures - MTC, Chapter 20.05.01.206.
- h) Fillet seal edge of doubler (1) to transmission deck using sealant (3). Refer to NOTE 1 in Figure 4. Refer to General Sealing Procedures - MTC, Chapter 20.05.01.206.
- i) Position drain sump assembly and secure using screws (11, 4 places), washers (12, 4 places) and nuts (13, 4 places). Refer to Figure 3.
- j) Position fuel filter support assembly (2) onto base aligning holes. If replacing fuel filter support assembly, match drill holes from base. Deburr holes. Refer to Figure 2.
- k) Secure fuel filter support assembly (2) onto base using (15 places [MS20470AD]).
- l) Seal around drain sump assembly (6) using sealing compound (17). Refer to Figure 3, Detail A. Refer to General Sealing Procedures - MTC, Chapter 20.05.01.206.
- m) Install plate (23) into fuel filter support assembly (8) and secure into place using rivets (18 places [110]), and (4 places [MS20470AD]).

NOTE: Do not seal between plate (23) and drain sump assembly (9).

- n) Position the fuel filter (16) in the top angle of the fuel filter support assembly (2). Secure into place using washer (11), and screw (10). Torque screw to required specification and secure with lockwire (8). Refer to Figure 2. Refer to Safetying with Lockwire, MTC, Chapter 20-02-06-402.

Transport Canada - Accepted

8. **REMOVAL AND REPLACEMENT** (continued)

B. **REPLACEMENT** (continued)

2) Hoses (Refer to Figures 2 and 3)

NOTE: Reuse clamps, hose end cover and spiral wrap from existing hose.

NOTE: Apply grease (14) to the nipple of the elbow (4) and to the inside diameter of the hoses (12a and b) before installation. Refer to Figure 2.

NOTE: To avoid any low or high spots in the routing of the fuel line hoses (12a or b) and to produce the least strain on the hoses, adjust the angle of elbows (4).

- a) If replacing either hose from fuel filter, repack FWD elbow (4) with packing (3b).
- b) If replacing hose (12a), install existing hose end cover (5) into one end of hose (12a). Connect hose to elbow (4) on the fuel filter. Hose end cover (5) to be opened up to fit elbow (4).
- c) Trim opposite end of hose (12a) to the required length to connect it to the existing fuel shut off hose. Install existing hose cover (5) into end of hose and secure to fuel shut off hose. Refer to Figure 2.
- d) Install spiral wrap on hose (12a) at point of contact with hose clamp (15).
- e) If replacing hose (12b), route the hose (12b) from the fuel tank, through the existing grommet in the transmission deck.
- f) Install the hose end cover (5) into the hose (12b), connect the hose to the AFT elbow (4). Hose end cover (5) to be opened up to fit elbow (4).
- g) Once hoses are adjusted secure using clamps (17).
- h) If replacing hose (10), connect the drain hose (10) to the drain sump assembly (6) and secure using hose clamp (18). Route hose through grommet (14) in drain bracket (5). Refer to Figure 3.
- i) Place spacer (19) between existing fuel line drain hose (13) and secure to existing fuel line using two ty-raps (20). Refer to Figure 2.
- j) Route the drain hose (13) to existing fuel drain line and clamp at existing fuel drain clamp location using clamp (17). Trim hose as required.
- k) Secure existing drain and hose (13) using hose clamp (17).
- l) Install new identification tag on replaced hose (12 a or b).

Transport Canada – Accepted

8. REMOVAL AND REPLACEMENT (continued)

B. REPLACEMENT (continued)

3) Fuel Filter (Refer to Figures 2 and 3)

- a) Position fuel filter (16) into fuel filter support assembly (2) and secure using previously removed screws (10, 3 places), and washers (11, 3 places). Torque screws to required specifications and secure using lockwire (8). Refer to Figure 2.
- b) Repack elbow (4, 1 place) on LHS of fuel filter (16) with new packing (3, 1 place). Reconnect hose (12) to elbow (4) and secure reusing hose clamps (6, 2 places).
- c) Repack elbow (4, 1 place) on RHS of fuel filter (16) with new packing (3, 1 place). Reconnect hose (12) to elbow (4) and secure reusing hose clamps (6, 2 places).

NOTE Apply grease (14) to the nipple of elbows (4, 2 places) and to the inside diameter of the hoses (12, 2 places) before installation.

If a new fuel filter has been installed, ensure ident label, shown in Figure 8 is installed facing outboard after fuel filter installation.

4) FUEL FILTER WIRING

- a) Refer to Airframe Fuel Filter wiring drawings in this document to replace damaged components or wiring.
 - b) Install in accordance with AC43.13-1B, Chapter 11.
 - c) Check electrical bonding in accordance with AC 43.13-1B, Chapter 11, Section 15, Paragraph 11-189.
- 5) Check After Maintenance Work - Fuel System in accordance with AS 350 B2/B3 AMM, Chapter 28-00-00, 6-2.
 - 6) Install the Purolator Dummy Filter Test Element (P/N 1741185), as per this document, and using the Purolator Operating Instruction for the filter assembly contained in this document in Appendix A, check for the correct operation of the fuel filter bypass function.
 - 7) Install the fuel filter element, and perform a leak check on runup.
 - 8) Close all areas opened for service in the PRELIMINARIES paragraph of this section.
 - 9) Before energizing the aircraft power supply system, read Safety Instructions (refer to General Safety Instruction - Electrical Power Supply System, AS 350 B2/B3 AMM, Chapter 24-00-00, 3-1).
 - 10) Reconnect the external power unit and battery (refer to Removal/Installation AS 350 B2/B3 AMM, Chapter 24-33-00, 4-1).
 - 11) Perform functional test - DC Power Supply System in accordance with AS 350 B2/B3 AMM, Chapter 24-30-00, 5-1.
 - 12) Close left MGB and engine cowlings.

Transport Canada - Accepted

9. WEIGHT AND BALANCE DATA

A. Removed Items

DESCRIPTION	WEIGHT		ARM		MOMENT	
	kg	lbs	m	in	kg m	lb in
Transmission Deck Cut-out	0.09	0.2	3.50	137.7	0.31	27.54
Total	-0.09	-0.2	3.50	137.7	-0.31	-27.54

B. Added Items

DESCRIPTION	WEIGHT		ARM		MOMENT	
	kg	lbs	m	in	kg m	lb in
Airframe Fuel Filter	0.91	2.0	3.50	137.8	3.19	275.6
Fuel Filter Support Assembly	0.28	0.6	3.50	137.8	0.98	82.7
Hardware and Harness	2.25	5.0	3.50	137.8	7.88	689.0
Total	3.44	7.6	3.50	137.8	12.04	1047.3

Transport Canada - Accepted

10. **PLACARDS AND MARKINGS**

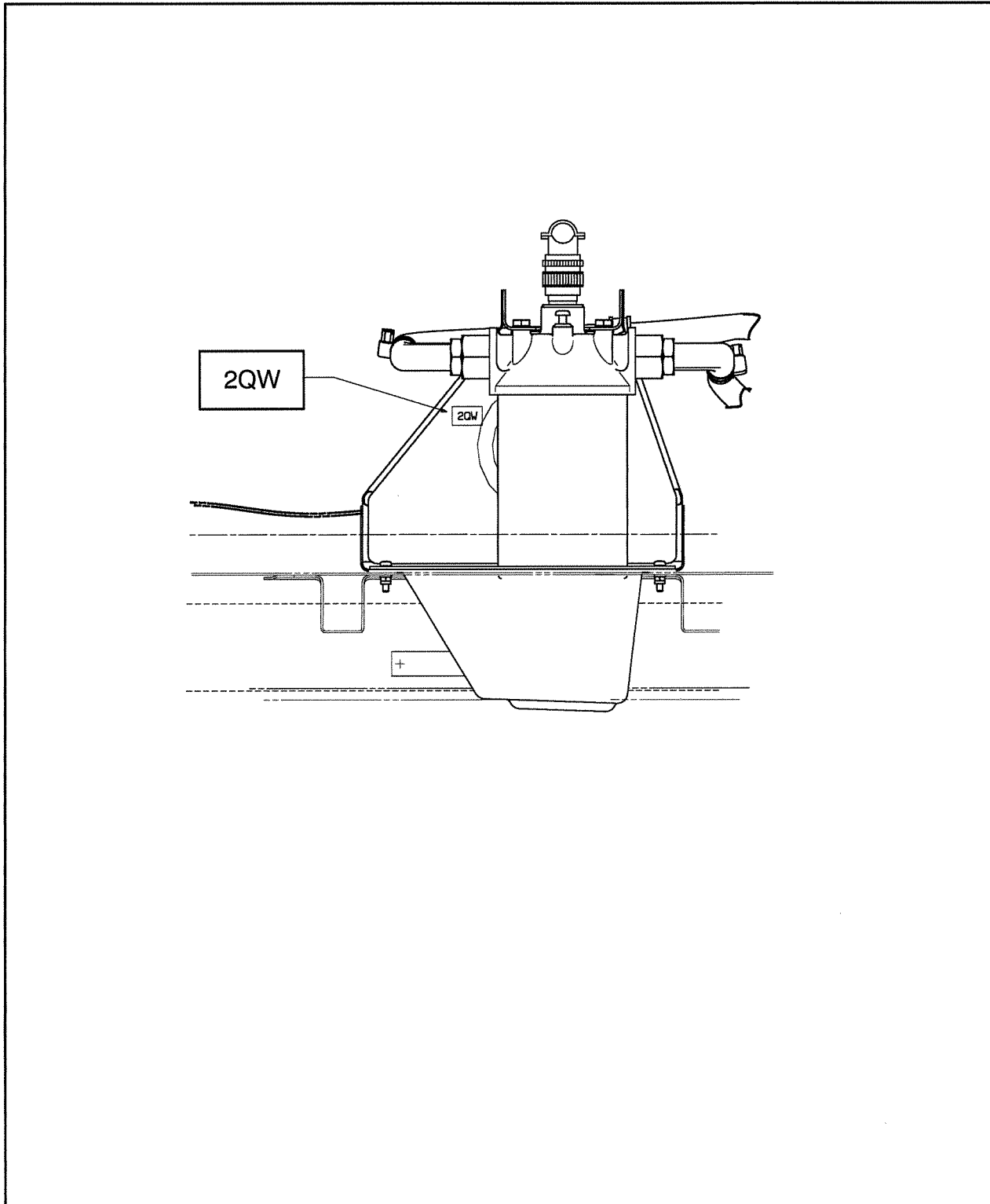

Figure 7 Identification Label on Fuel Filter Support Assembly

Transport Canada - Accepted

10. **PLACARDS AND MARKINGS**

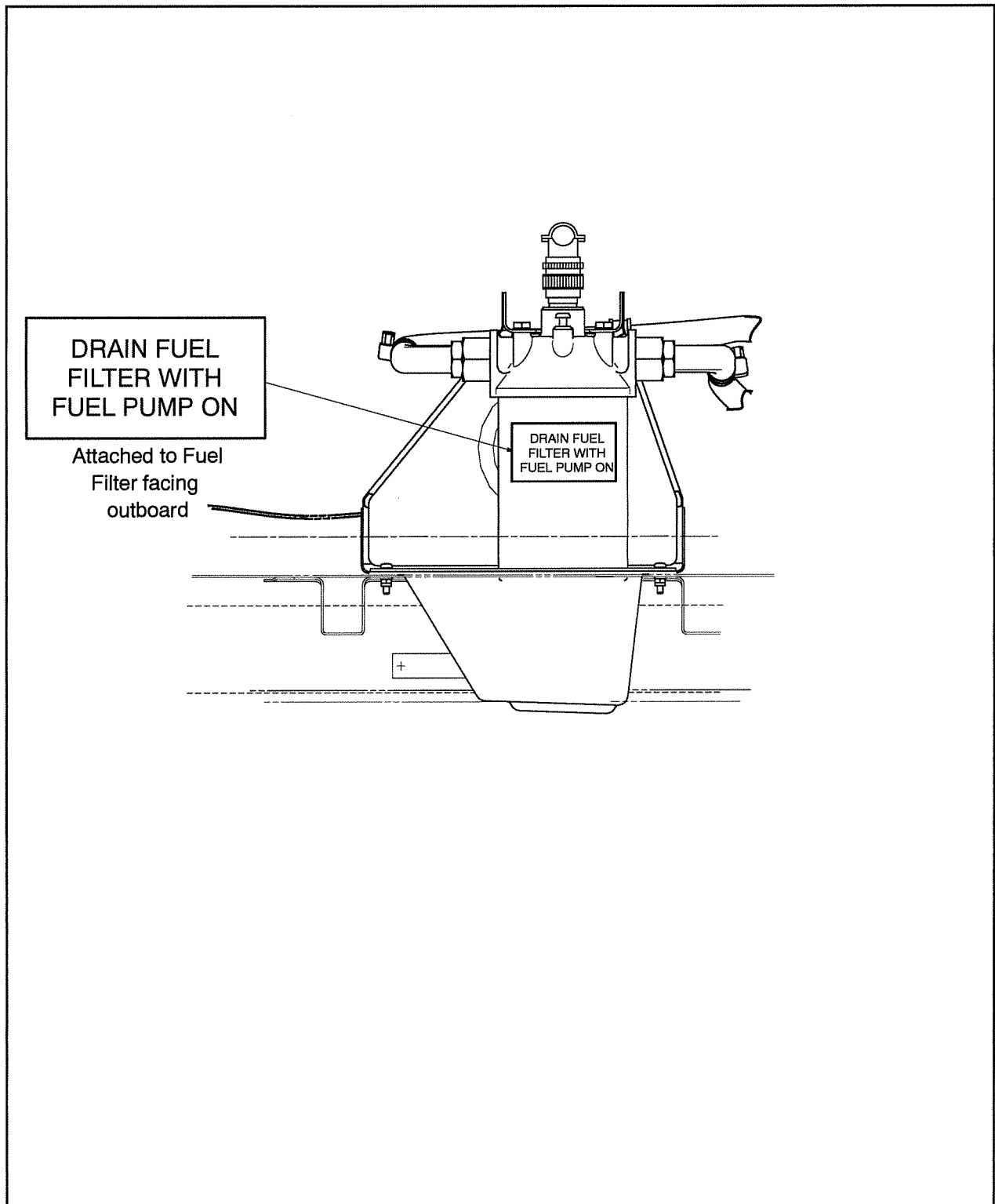

Figure 8 Placard on Fuel Filter

Transport Canada - Accepted



10. **PLACARDS AND MARKINGS** (continued)

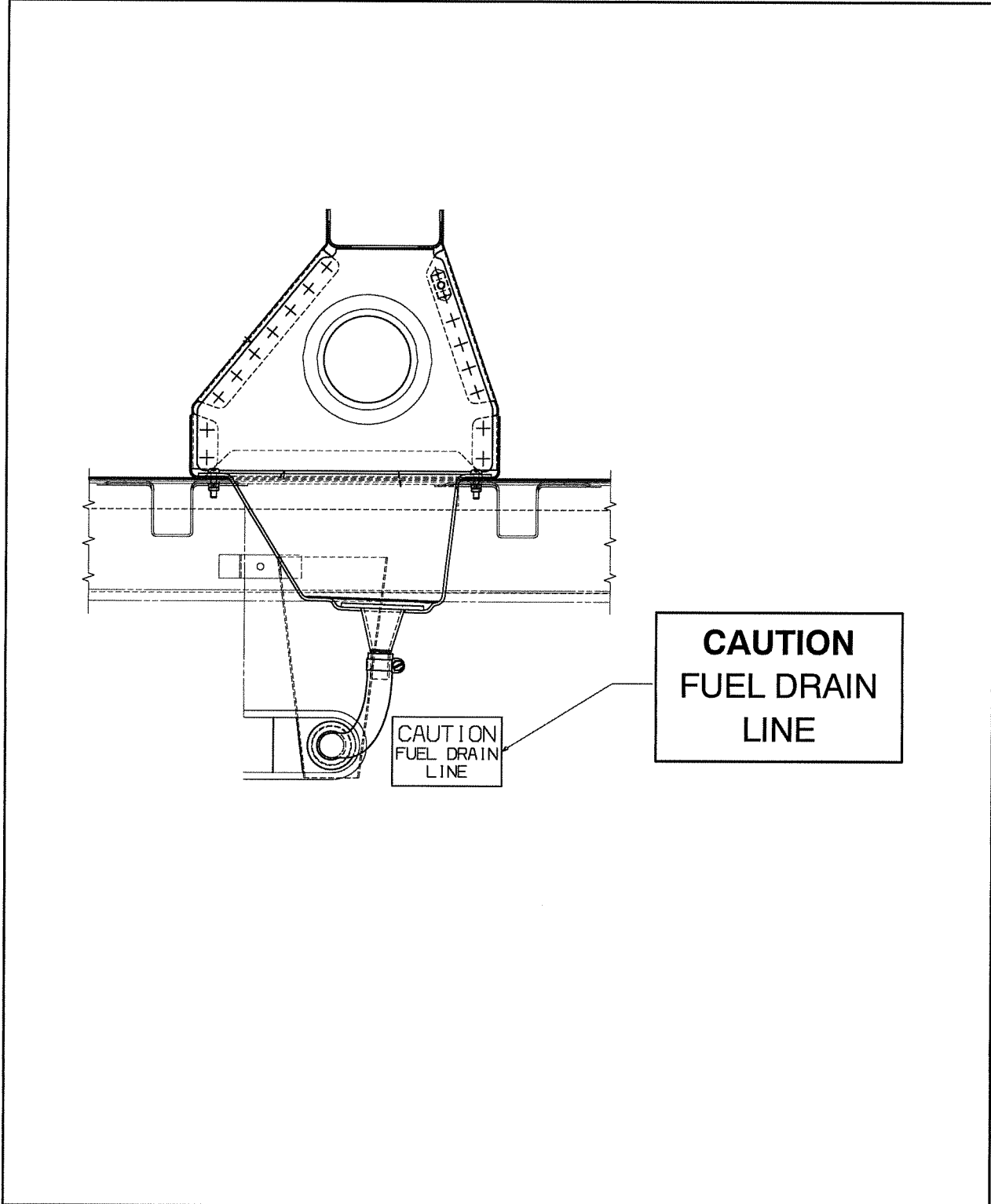

Figure 9 Placard in LH Cargo Compartment

Transport Canada - Accepted



1BLACARDS AND MARKINGS (continued)

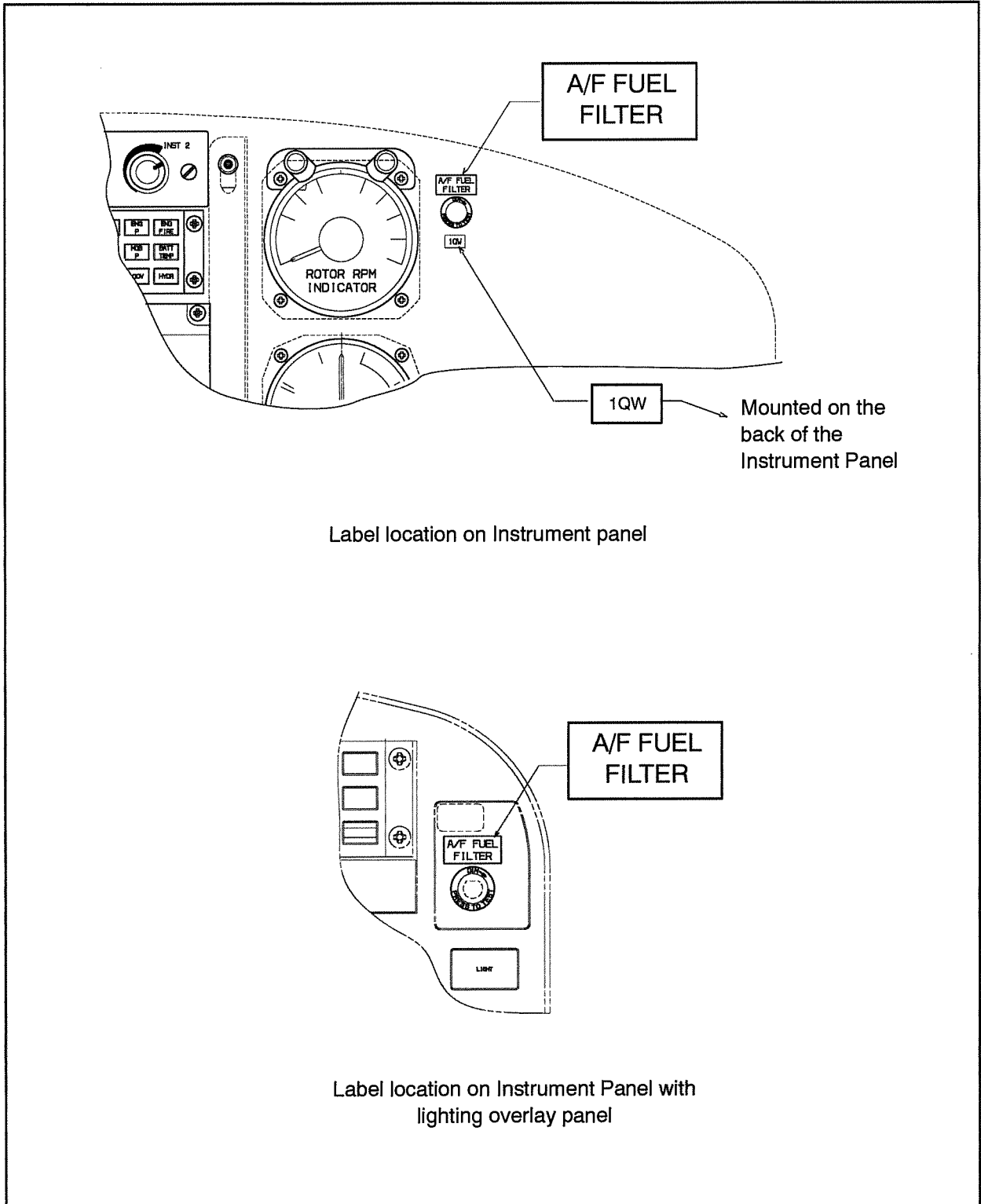

Figure 10 Placard and Identification Label on Instrument Panel

Transport Canada - Accepted

10. **PLACARDS AND MARKINGS** (continued)

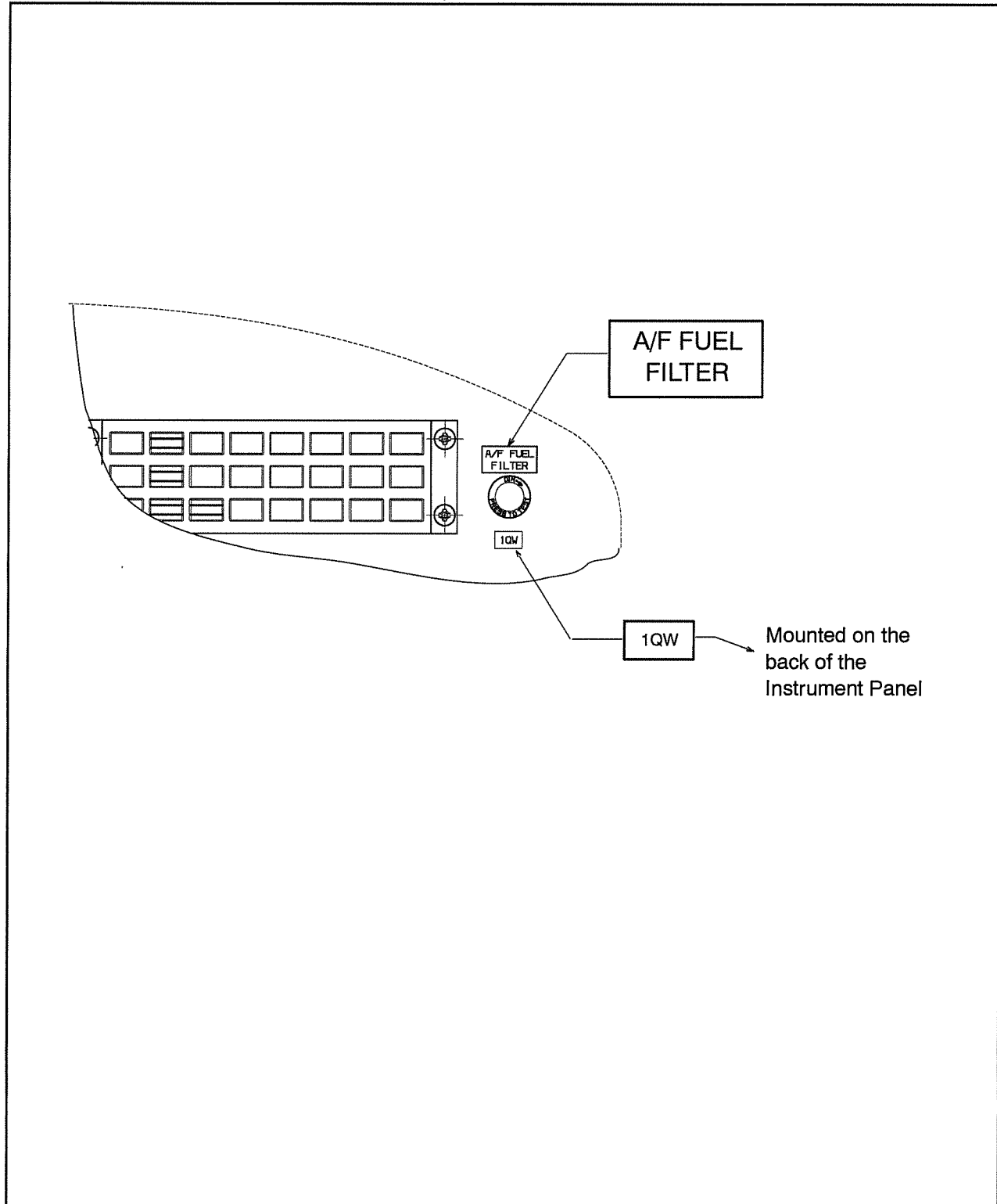

Figure 11 Placard and Identification Label on alternative Instrument Panel

Transport Canada – Accepted

10. **PLACARDS AND MARKINGS** (continued)

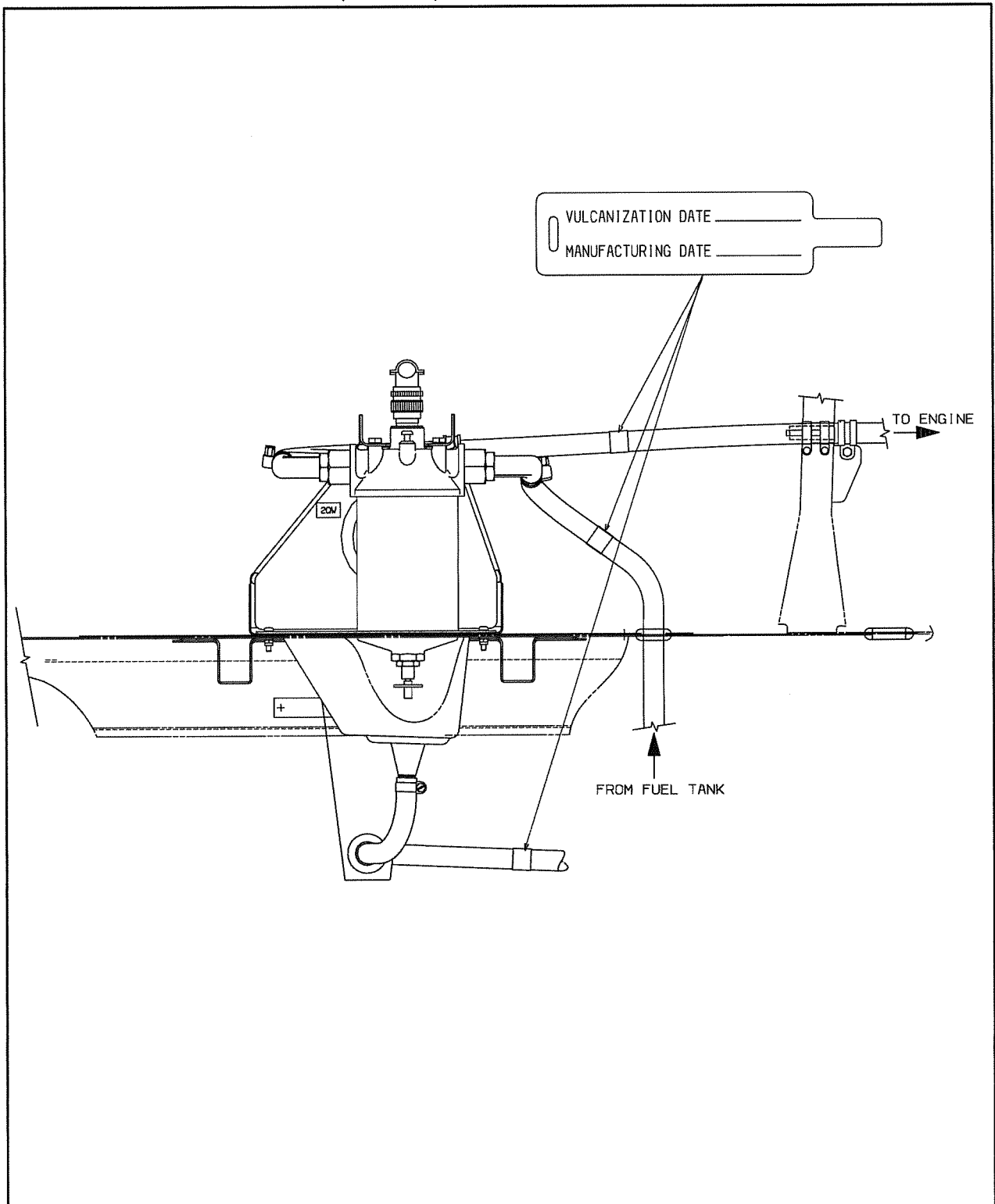

Figure 12 Identification Tags on hoses

Transport Canada - Accepted



**Operating & Design Specifications
Fuel Filter Assembly
Part No.: 1743640-01**

Purolator Facet Inc.
8439 Triad Drive, Greensboro, NC 27409-9621
Phone: (336) 668-4444, Fax (336) 668-4452

Purolator Fuel Filter Assembly Part No. 1743640-01

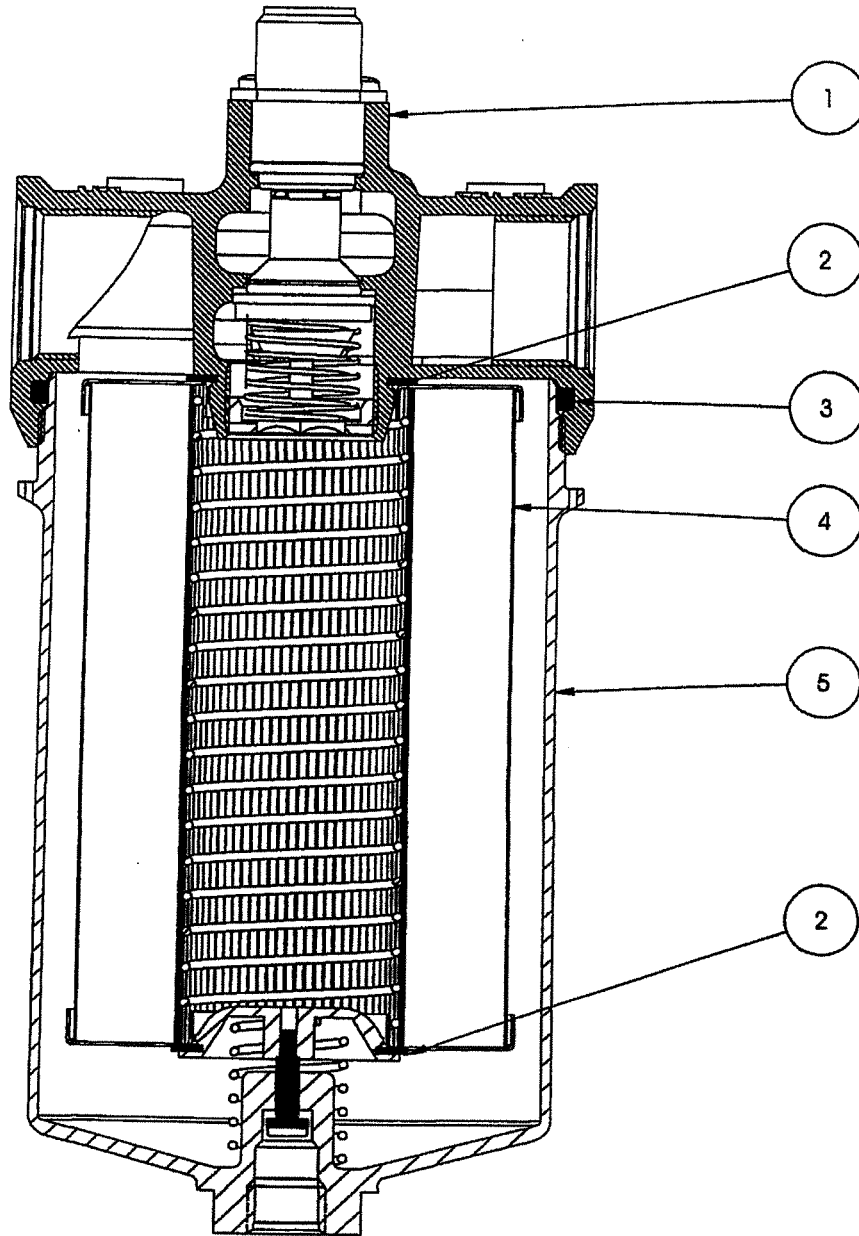

Replacement Parts for Filter Assembly Part No. 1743640-01

Item No.	Qty. Req.	Part No.	Description:
1.	1	1744990-01	Head Assembly
2.	2	1743629-01	Seal
3.	1	034921-01	O-Ring
4.	1	1743645-01	Element Assembly
5.	1	1745011	Bowl Assembly

NOTE: Purolator replacement element kit part no. 1743645-02 consists of items 2, 3 & 4

Operating Instructions:

Preflight Inspection Procedure Change:

1. Follow aircraft manufacturers recommended preflight instructions.
-

Scheduled Maintenance:

1. Fuel Filter Element Change:
 - A. Replace element at the intervals specified by the aircraft manufacturer.
 - B. Remove lockwire and unscrew filter bowl.
 - C. Remove used element.
 - D. Remove O-Ring and flat seals from filter head and inside of bottom of filter bowl.
 - E. Install new seals P/N: 1743629-01 on the nipple of the filter head and retainer in the filter bowl.
 - F. Install new filter element p/n: 1743645-01.
 - G. Install new O-Ring P/N: 034921-01 in the filter head.
 - H. Re-install filter bowl and torque to 130±20 inch pounds.
 - I. Secure filter head to filter bowl with lockwire.

**Purolator Fuel Filter Assembly
Part Number 1743640-01**

Design Specifications:

1. Filtration Rating: 10 Micrometres Nominal
2. Fluid: Mil-T 5624 Gr. JP-4, JP-5, ASTM-D-1655 Type A, A1 or B.
3. Temperature Range: -65°F to +160°F.
4. Bypass valve cracking Pressure: 3.75 PSID.
5. Microdelta® Differential Pressure Switch actuates at 0.875 PSID
7. Pressures: Operating: 60 PSI
 Proof: 90 PSI
 Burst: 180 PSI
8. Rated Flow: 0.5 GPM
9. Weight: 1.75 lbs. Max.