



EUROCOPTER CANADA LIMITED

SUBJECT:

Required maintenance for the Wire Strike Protection System (P/N 130-300214).

APPLICABILITY:

Aircraft with the subject modification embodied in accordance with TCCA STC. No. SH05-39 or any relevant foreign approvals.



THE INFORMATION CONTAINED IN THIS DOCUMENT SHALL BE TREATED AS THE PROPERTY OF EUROCOPTER CANADA LIMITED (ECL). THE RECIPIENT OF THIS DOCUMENT SHALL NOT DISCLOSE ANY INFORMATION CONTAINED HEREIN TO THIRD PARTIES WITHOUT THE WRITTEN PERMISSION OF ECL, AND SHALL NOT USE OR REPRODUCE THIS DOCUMENT IN WHOLE OR IN PART FOR ANY PURPOSE OTHER THAN ITS ORIGINALLY INTENDED PURPOSE, OR TO EVALUATE ITS CONTENTS.

	NAME AND SIGNATURE	DATE	COMPANY / DEPARTMENT
PREPARED BY:	D. Kerr <i>D Kerr</i>	25 Aug. 05	ECL ENGINEERING
PREPARED BY:			ECL ENGINEERING
CHECKED BY:	C. Timmins <i>C. Timmins</i>	29 th August 2005	ECL ENGINEERING
CHECKED BY:	M. Merritt <i>M Merritt</i>	2005-08-29	ECL QUALITY ASSURANCE
APP'D / ACCEPTED (Civil A/W Authority)	(See TCCA stamp)		TCCA
RELEASED BY:	R. Manson <i>R Manson</i>	8 Sep 2005	ECL ENGINEERING

CONTENTS

SECTION	TITLE	PAGE
1	GENERAL	4
2	AIRWORTHINESS LIMITATIONS	6
3	CONTROL AND OPERATION	7
4	INSPECTION SCHEDULE AND MAINTENANCE ACTION	7
5	OVERHAUL REQUIREMENTS	10
6	TROUBLESHOOTING	10
7	SPECIAL TOOLING	11
8	REMOVAL AND REPLACEMENT	11
9	WEIGHT AND BALANCE DATA	13
10	PLACARDS AND MARKINGS	19

Appendix A Wire Strike Protection System, Magellan Aerospace Corporation / Bristol Aerospace Limited, Maintenance Manual Supplement and Illustrated Parts List, Document Number PM-965-054A, Rev. A, Issued 3 August 2005, (17 Pages)

FIGURES

FIGURE	TITLE	PAGE
1	Wire Strike Protection System - Installation	4
2	Upper Cutter Detachable Provisions	14
3	Lower Cutter Detachable Provisions	15
4	Upper Cutter Details	16
5	Lower Cutter Details	17
6	Roof Reinforcement - Composite Layup	18
7	View showing relocated placard location on Overhead Panel	19

TABLES

TABLE	TITLE	PAGE
1	Inspection Schedule and Maintenance Action Before the first flight of each day	7
2	Inspection Schedule and Maintenance Action Every 100 flight hrs or 12 months	8
3	Inspection Schedule and Maintenance Action Supplemental Maintenance Instructions	9

TC Accepted
AUG 30 2005
JZ

1. **GENERAL**

A. Introduction

The Wire Strike Protection System (WSPS) is designed to provide a measure of protection from inadvertent flight into horizontally strung wires and cables.

B. Description

The Wire Strike Protection System (WSPS) consists of two cable-cutting devices, one mounted on the upper part of the forward fuselage, another on the lower part of the forward fuselage, and an airframe structure reinforcement. The Air Intake Cowling is also modified to provide clearance for the upper cutter. Inserts mounted into the roof enable the upper cutter to be secured into place. The lower cutter is secured to the chin panel directly behind the center window and reinforced by the addition of an internally mounted frame. The forward tip of the lower cutter is designed to break away in the event of contact with the ground.

NOTE If the aircraft is PRE AMS OP-3560, the roof has been reinforced in accordance with ECL drawing number 130-200394.

The Wire Strike Protection System consists of the following main components:

Detachable Provisions

- Upper cutter assembly
- Lower cutter assembly

Fixed Provisions

- Inlet Cap
- Doubler Angle
- Frame
- Doubler
- AFT Angle

For instructions for initial installation, see IP-ECL-113.

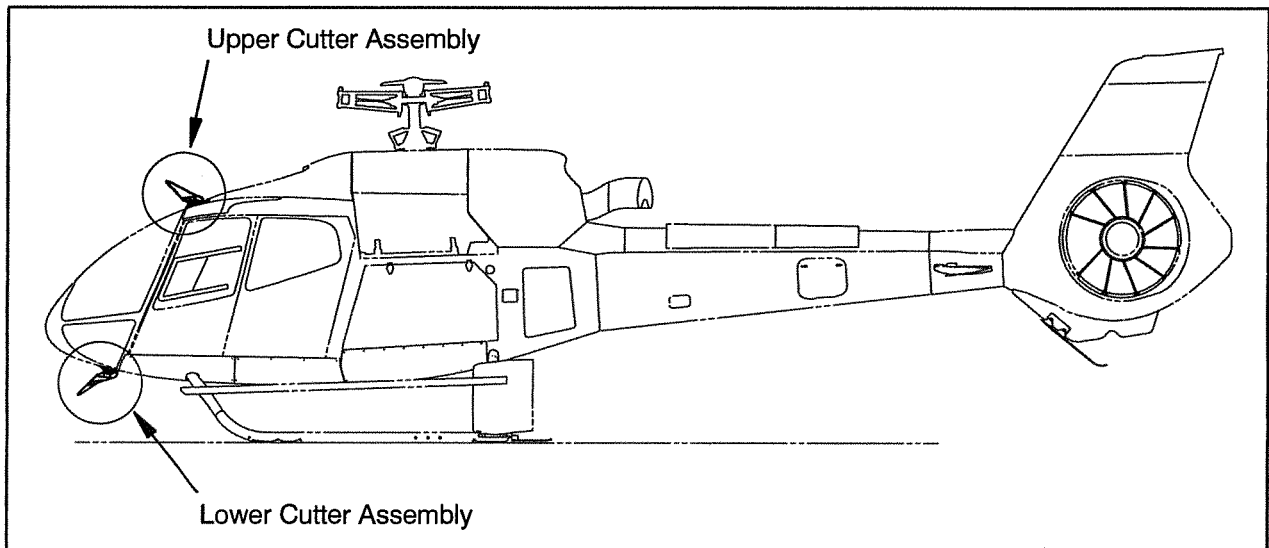
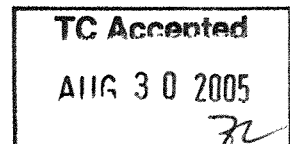

Figure 1 Wire Strike Protection System - Installation

Transport Canada - Accepted



EUROCOPTER CANADA LIMITED

C. REFERENCES

DOCUMENT	DOCUMENT TITLE
AMM	Aircraft Maintenance Manual
AMS OP-3560	Roof Reinforcement Modification
MSM	Master Servicing Manual
MTC	Standard Practices Manual
IP-ECL-113	Installation Procedure, Wire Strike Protection System

D. ABBREVIATIONS & DEFINITIONS

ABBREVIATION	DEFINITION
EC	Eurocopter (France)
ECL	Eurocopter Canada Limited
hrs	hours
P/N	Part Number
WSPS	Wire Strike Protection System
LHS	Left Hand Side
RHS	Right Hand Side

E. UNITS OF MEASUREMENT

ABBREVIATION / SYMBOL	UNIT OF MEASUREMENT
kg	kilogram
lb	pound
m	meter
in	inch

Transport Canada - Accepted

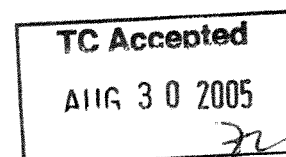

2. AIRWORTHINESS LIMITATIONS

The Airworthiness Limitations section is approved by the Minister and specifies maintenance required by any applicable airworthiness or operating rule unless an alternative program has been approved by the Minister.

No airworthiness limitations associated with this installation.

TC Approved
AUG 30 2005

Transport Canada - Approved

EUROCOPTER CANADA LIMITED

3. CONTROL AND OPERATION

Control and operation of the aircraft remains unchanged.

4. INSPECTION SCHEDULE AND MAINTENANCE ACTION

WARNING: TO AVOID INJURIES, THE LOWER CUTTER ASSEMBLY MUST NOT BE USED FOR GROUND HANDLING OF THE HELICOPTER.

For additional information on inspection and maintenance, refer to the Magellan Aerospace/Bristol Aerospace Maintenance Manual Supplement and Illustrated Parts List located in Appendix A as indicated below.

Use torque per EC MTC, Volume 2, Chapter 20.02.05.404, unless otherwise specified.

4.1. INSPECTION SCHEDULE

4.1.1. Before the first flight of each day:

ITEM	INSPECTION OR MAINTENANCE WORK	CORRECTIVE ACTION
A	<ul style="list-style-type: none"> - Visually inspect cutter blades , item 1, in Figures 2 and 3 for: <ul style="list-style-type: none"> a. condition b. security c. ground contact on lower cutter d. evidence and indication of wire strike 	<ul style="list-style-type: none"> a. If sealant damaged or missing, reapply sealing compound (P/N PR1422). If blade is damaged, contact ECL for replacement parts. b. To check for looseness, apply hand pressure to assembly. Retighten as required. c. Replace breakaway tip (see Figure 3, View A) in accordance with Appendix A if damaged or loose rivets are found. d. Refer to Sections 4.1.2 and 4.1.3.

Table 1 Inspection Schedule and Maintenance Action
Before the first flight of each day

Transport Canada - Accepted

TC Accepted
 AUG 30 2005

EUROCOPTER CANADA LIMITED

4.1. INSPECTION SCHEDULE (continued)

4.1.2. Every 100 flight hrs or 12 months (to coincide with the 100 hrs or 12 month helicopter inspection or if wire strike is suspected):

ITEM	INSPECTION OR MAINTENANCE WORK	CORRECTIVE ACTION
A	<ul style="list-style-type: none"> - Visually inspect complete Wire Strike Protection System for: <ul style="list-style-type: none"> a. scoring b. corrosion 	<ul style="list-style-type: none"> a. If scoring is found, refer to Appendix A. b. If corrosion is found, refer to Appendix A.
B	<ul style="list-style-type: none"> - Visually inspect cutter blades, items 8 and mounting angles, items 9, in Figure 2 respectively (refer to Appendix A) for: <ul style="list-style-type: none"> a. minor nicks and scratches b. cracks or deformation 	<ul style="list-style-type: none"> a. If minor nicks and scratches are found, repair in accordance with Appendix A. b. No cracks or deformation are allowed. If cracks or deformation are found refer to Section 4.1.3.
C	<ul style="list-style-type: none"> - Visually inspect all fasteners for: <ul style="list-style-type: none"> a. condition b. security 	<ul style="list-style-type: none"> a. Replace if damaged. Refer to Appendix A. b. Secure as required. Refer to Appendix A.
D	<ul style="list-style-type: none"> - Visually inspect aircraft structure for: <ul style="list-style-type: none"> a. damage 	<ul style="list-style-type: none"> a. If permanent structure damage is evident, refer to Section 4.1.3.
E	<ul style="list-style-type: none"> - Check placard for: <ul style="list-style-type: none"> a. legibility b. secure mounting (refer to Section 10, Placards and Markings) 	<ul style="list-style-type: none"> a. If placard has become illegible, contact ECL for replacement part. b. Secure or reattach placard as required.

NOTE If evidence of a wire strike is apparent, refer to Section 4.1.3 and AMM.

Table 2 Inspection Schedule and Maintenance Action
Every 100 flight hrs or 12 months

Transport Canada - Accepted

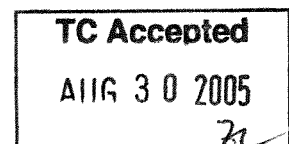

EUROCOPTER CANADA LIMITED

4.1. INSPECTION SCHEDULE (continued)

4.1.3. Supplemental Maintenance Instructions (only if wire strike is apparent after section 4.1.2 has been completed):

WARNING Carry out detailed inspection of complete aircraft in accordance with MSM in addition to the following:

ITEM	INSPECTION OR MAINTENANCE WORK	CORRECTIVE ACTION
A	- Visually inspect cutter blades, item 8, and mounting angles, item 9, in Figure 2 (refer to Appendix A) for: a. damage	a. Refer to Appendix A.
B	- Visually inspect the doubler angle, item 6, in Figure 2 for: a. cracking around mounting holes (2 places)	a. No cracking is allowed. If cracking is found, contact ECL for replacement parts.
C	- Visually inspect the doubler, item 8, in Figure 3 for: a. surface cracking and cracking around mounting holes (4 places) b. deformation	a. No cracking is allowed. If cracking is found, contact ECL for replacement parts. b. No deformation is allowed. If deformation is found, contact ECL for replacement parts.
D	- Visually inspect the airframe reinforcement, item 7, Figure 3 for: a. cracking around mounting holes (2 places)	a. No cracking is allowed. If cracking is found, contact ECL for replacement parts.
E	- Visually inspect roof inserts, item 2, in Figure 4 for: a. security (upper cutter assembly must be removed for this inspection)	a. Remove the adhesive (P/N EA9396) from core surrounding the loose insert. Reinstall each insert through bottom of hole, securing it into place with a screw coated with release agent. Refill core cavity with adhesive paste (mix adhesive P/N EA9396 with microballoons P/N BJOA0930 at a ratio of 10:3). Cure the adhesive at room temperature for 24 hours. Remove the screw securing the insert.

Table 3 Inspection Schedule and Maintenance Action
Supplemental Maintenance Instructions
(continued on following page)

Transport Canada - Accepted

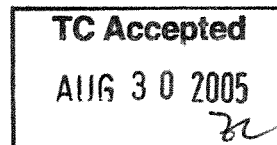

EUROCOPTER CANADA LIMITED

4.1. INSPECTION SCHEDULE (continued)

4.1.3. Supplemental Maintenance Instructions (continued):

ITEM	INSPECTION OR MAINTENANCE WORK	CORRECTIVE ACTION
F	<ul style="list-style-type: none"> - Remove overhead panel and visually inspect area around roof inserts, item 2, Figure 4 for: <ul style="list-style-type: none"> a. cracking 	<ul style="list-style-type: none"> a. Follow same corrective action given in Section 4.1.3., item E.
G	<ul style="list-style-type: none"> - Visually inspect the aft angle, item 2, in Figure 5 for: <ul style="list-style-type: none"> a. cracking around mounting holes (2 places) 	<ul style="list-style-type: none"> a. No cracking is allowed. If cracking is found, contact ECL for replacement parts.
H	<ul style="list-style-type: none"> - Visually inspect the rivets, item 5, Figure 5 for: <ul style="list-style-type: none"> a. cracking and deformation 	<ul style="list-style-type: none"> a. No cracking or deformation allowed. If cracking or deformation is found, replace rivets where applicable.
I	<ul style="list-style-type: none"> - Visually inspect cabin roof for: <ul style="list-style-type: none"> a. cracking, depressions or holes 	<ul style="list-style-type: none"> a. If cracking, a depression or a hole is found, repairs must be performed by qualified composite personnel. If aircraft is PRE AMS OP-3560, repairs may be accomplished (ref. Figure 6) with EC MTC, Volume 3 Chapters 20.03.06.401 and 20.03.06.402, and AC43.13-1B, Chapter 3, Section 1. If aircraft is POST AMS OP-3560, repairs may be accomplished (ref. Figure 6 for materials) with EC MTC, Volume 3 Chapters 20.03.06.401 and 20.03.06.402, and AC43.13-1B, Chapter 3, Section 1.
J	<ul style="list-style-type: none"> - Visually inspect the lower part of the forward fuselage <ul style="list-style-type: none"> a. cracking, depressions or holes 	<ul style="list-style-type: none"> a. If cracking, a depression or a hole is found, repairs must be performed by qualified composite personnel. Repairs may be accomplished (ref. Figure 6 for materials) with EC MTC, Volume 3 Chapters 20.03.06.401 and 20.03.06.402, and AC43.13-1B, Chapter 3, Section 1.

Table 3 Inspection Schedule and Maintenance Action
Supplemental Maintenance Instructions

Transport Canada - Accepted

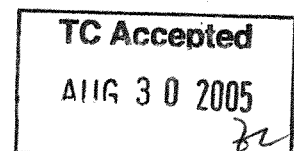

5. OVERHAUL REQUIREMENTS

No overhaul requirements for this installation.

6. TROUBLESHOOTING

There are no unique characteristics which require special troubleshooting techniques; standard techniques are adequate.

7. SPECIAL TOOLING

No special test equipment or tools are required. Standard tools are adequate.

8. REMOVAL AND REPLACEMENT

Proceed as follows if any of these items need to be removed.

Refer to Figures 2, Upper Cutter Detachable Provisions, and Figure 3, Lower Cutter Detachable Provisions, for component removal and replacement.

NOTE For information on disassembly of cutter assemblies refer to the Bristol Aerospace Maintenance Manual Supplement and Illustrated Parts List (Appendix A).

A. REMOVAL

- 1) Upper Cutter (Refer to Figure 2)
 - a) Remove bolts (2) (6 places), and washers (3) (6 places) from the cabin roof.
 - b) Remove FWD bolts (7) (2 places) and washers (3) (2 places) from the cabin roof. Remove nuts (5) (2 places), washers (3) (2 places) and spacers (4) (2 places) from between the roof and the carbon beam.
 - c) Carefully remove the sealing compound and the upper cutter assembly (1).
- 2) Lower Cutter (Refer to Figure 3)
 - a) Remove bolts (2) (4 places) and washers (3) (4 places).
 - b) Carefully remove the sealing compound and the lower assembly cutter (1).

Transport Canada - Accepted

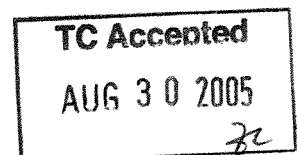

8 REMOVAL AND REPLACEMENT (continued)

B. REPLACEMENT

NOTE For information on assembly of cutter assemblies refer to the Bristol Aerospace Maintenance Manual Supplement and Illustrated Parts List (Appendix A).

NOTE Use torque per EC MTC, Volume 2, Chapter 20.02.05.404, unless otherwise specified.

- 1) Upper Cutter (Refer to Figure 2)
 - a) Ensure contact area is free of all non-conductive coating. Protect bare metal surface with protective coating (Nycote).
 - b) Secure upper cutter assembly (1) into place using bolts (2) (6 places), and washers (3) (6 places) coated with sealant (P/N PR1422).
 - c) Place spacer (4) (2 places) into carbon beam.
 - d) Secure LHS using bolt (7) (1 place), washer (3) (2 places), and nut (5) (1 place). Dome seal nuts with sealant (P/N PR1422).
 - e) Secure RHS using bolt (7) (1 place), washer (3) (2 places), and nut (5) (1 place). Dome seal nuts with sealant (P/N PR1244).
 - f) After assembly, bare metal surfaces to be protected with protective coating (Nycote).
- 2) Lower Cutter (Refer to Figure 3)
 - a) Ensure contact areas are clean of all non-conductive coating to a diameter of 8 mm. Protect bare metal surface with protective coating (Nycote).
 - b) Position the lower cutter assembly (1) on the doubler.
 - c) Secure lower cutter assembly to aircraft using washer (3) (4 places), and bolts (2) (4 places).
 - d) Install the aft hardware with sealant (P/N PR1422).
 - e) Fillet seal around fastener heads of forward hardware with sealant (P/N PR1422).

Transport Canada - Accepted

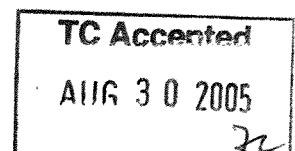

EUROCOPTER CANADA LIMITED

9. WEIGHT AND BALANCE DATA

A. <u>Weight and Balance of Components Installed</u>						
DESCRIPTION	WEIGHT		ARM		MOMENT	
	kg	lb	m	in	m kg	in lb
Wire Strike Protection System (complete)	5.37	11.9	0.88	34.9	4.75	415.2
- Upper Cutter Fixed Provisions (P/N 130-200234)	0.36	0.8	1.43	56.4	0.51	45.1
- Upper Cutter Detachable Provisions (P/N 130-200244)	1.95	4.3	1.28	50.6	2.50	217.6
- Lower Cutter Fixed Provisions Provisions (P/N 130-200314)	1.30	2.9	0.66	26.1	0.86	75.7
- Lower Cutter Detachable Provisions (P/N 130-200324)	1.76	3.9	0.50	19.7	0.88	76.8

B. <u>Weight and Balance of Components Removed</u>						
- Not applicable						

NOTE Minor calculation discrepancies may result from round-off errors.

Transport Canada - Accepted

<p>TC Accepted AUG 30 2005 <i>zc</i></p>

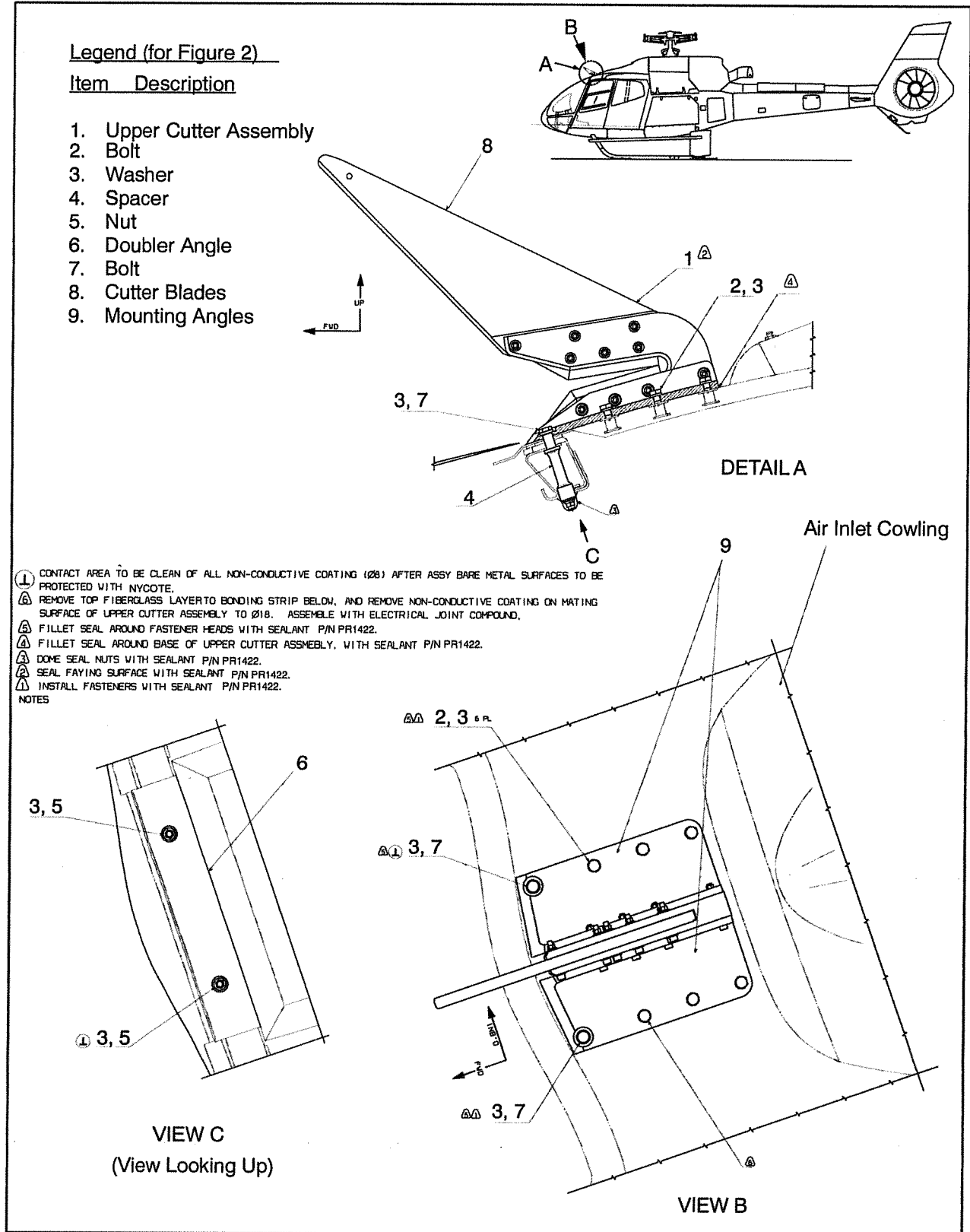

Figure 2 Upper Cutter Detachable Provisions

Transport Canada - Accepted

TC Accepted
AUG 30 2005
zc

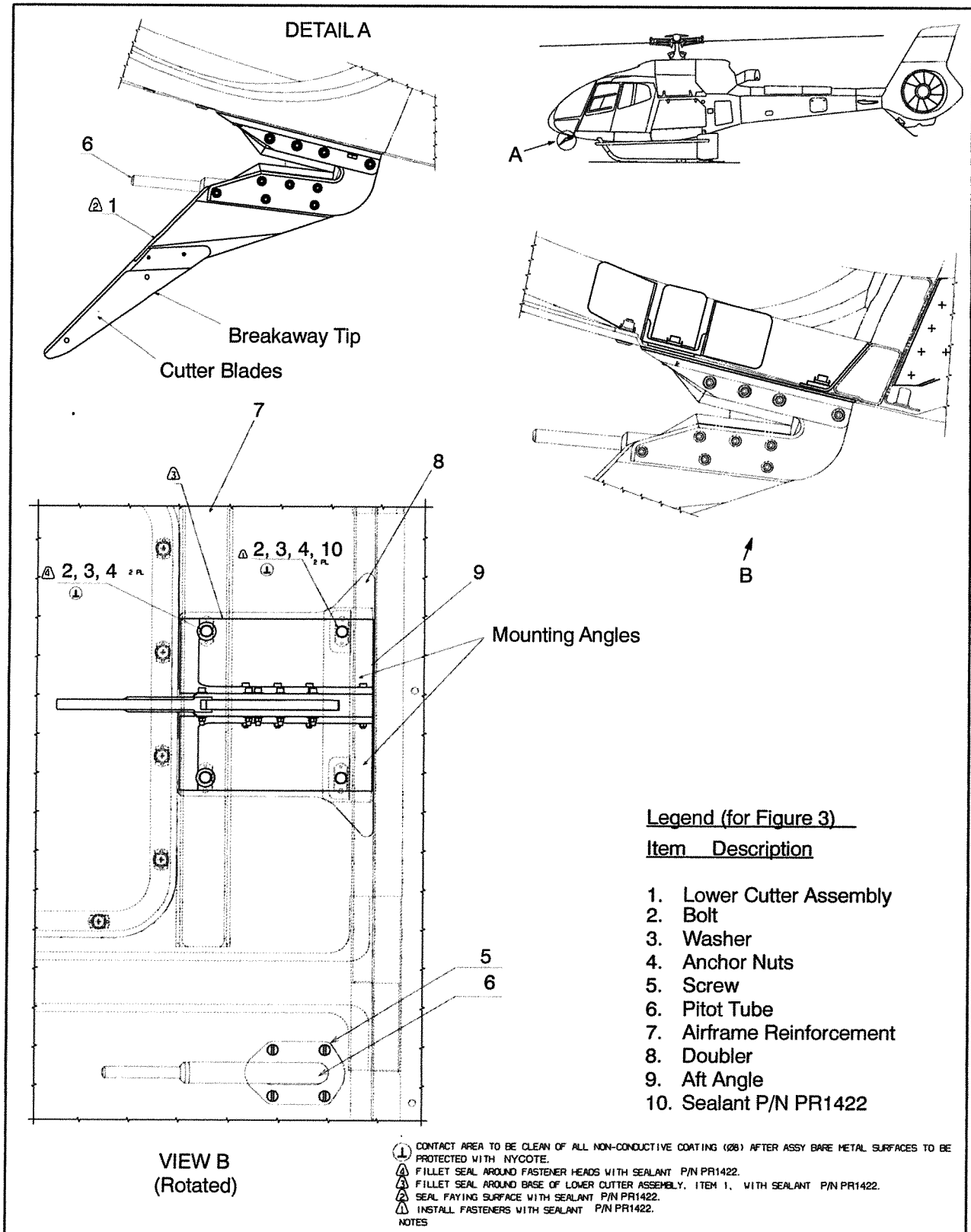
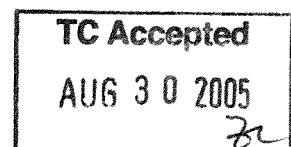

Figure 3 Lower Cutter Detachable Provisions

Transport Canada - Accepted



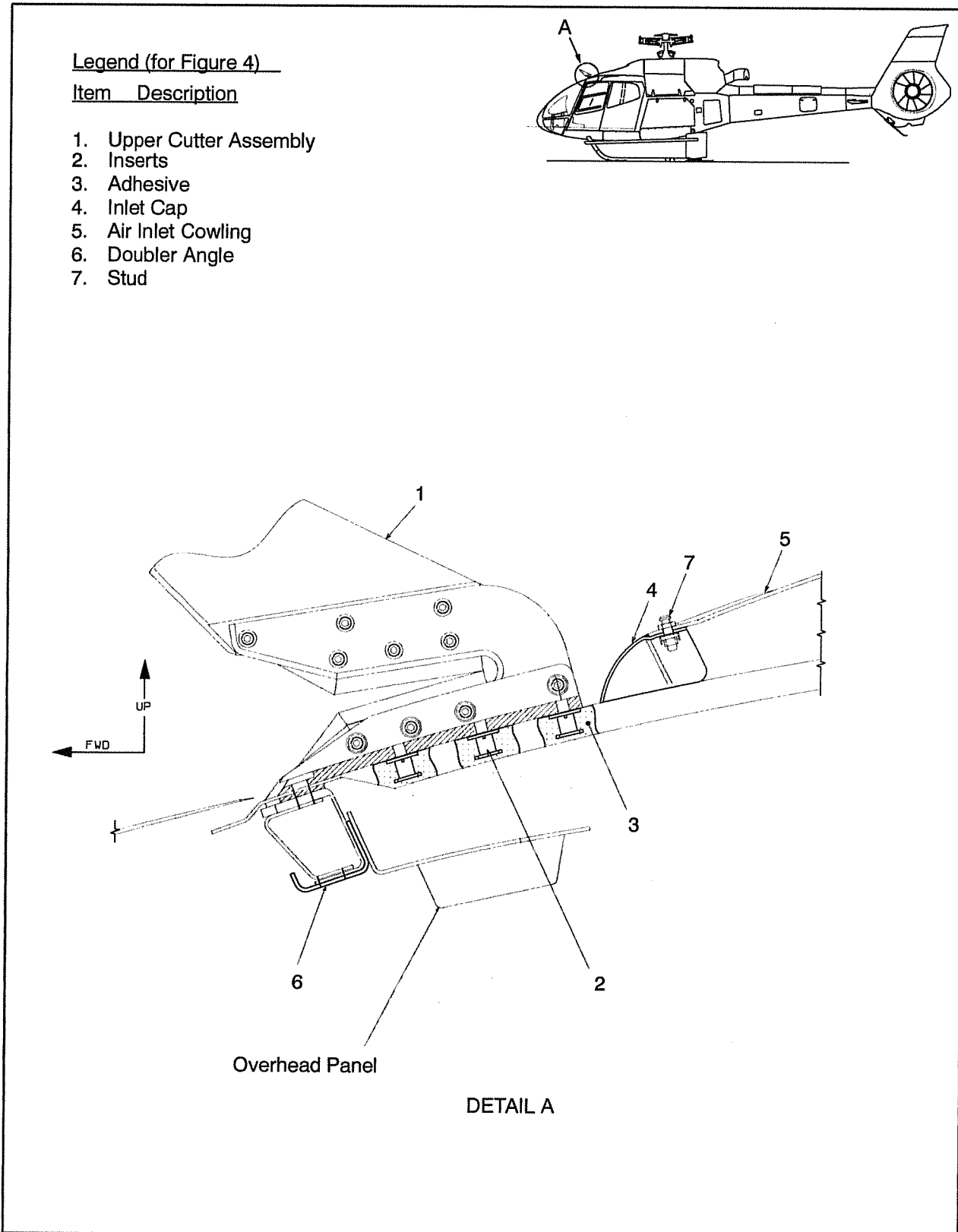

Figure 4 Upper Cutter Details

Transport Canada - Accepted

TC Accepted
AUG 30 2005
RL



Legend (for Figure 5)

Item Description

- 1. Lower Cutter Assembly
- 2. Aft Angle
- 3. Airframe Reinforcement
- 4. Anchor Nuts
- 5. Rivets

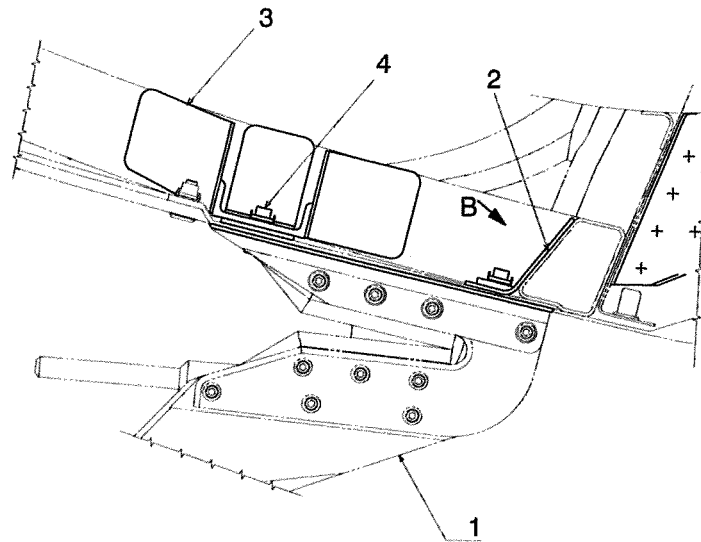
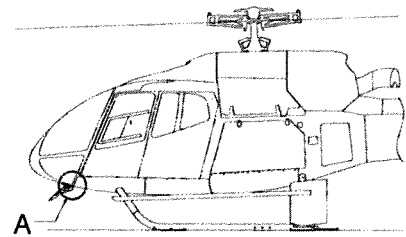

VIEW A

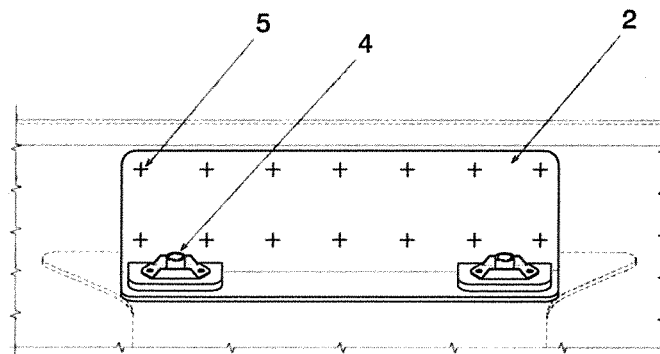

DETAIL B
(Rotated)

Figure 5 Lower Cutter Details

Transport Canada - Accepted

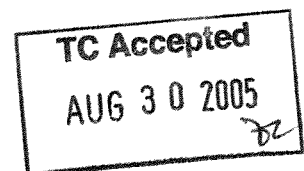

Legend (for Figure 6)

Item Description

1. Carbon Fabric P/N Style 3K-70-PW or K Gew Carbon Fabric P/N MI-10126
2. Fiberglass Cloth P/N 8.4548.60 or Fiberglass Cloth P/N STYL 7781
3. Adhesive P/N EA9396
4. EMI Shielding Tape P/N 1181

Roof Reinforcement
PRE AMS OP-3560

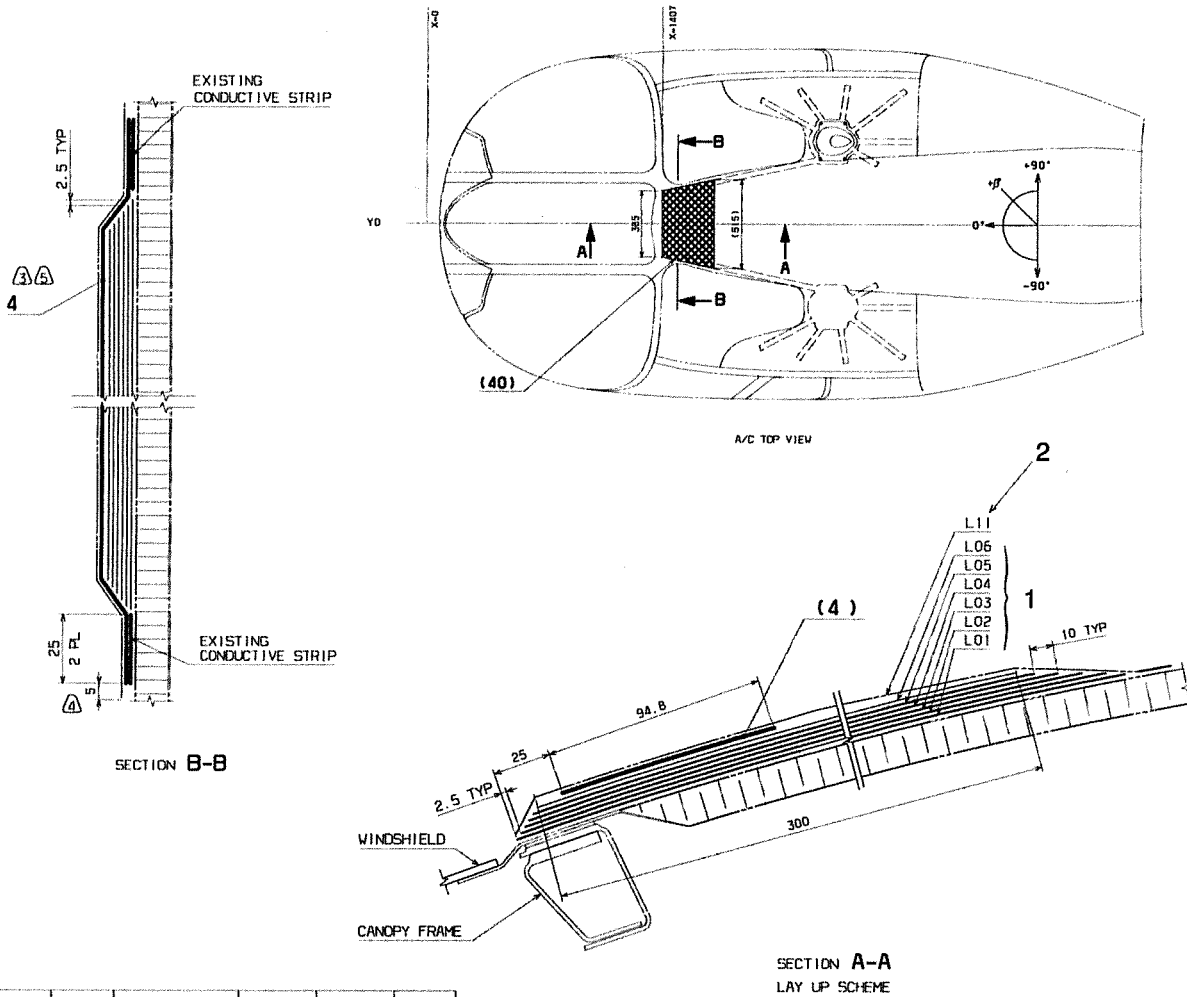
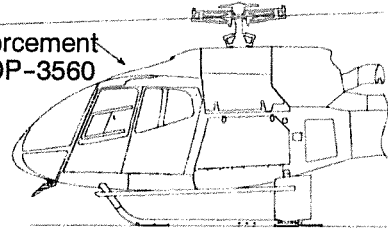

ITEM NO	LAYER NO	FIBRE OR WARP DIRECTION	LENGTH (MM)	WIDTH (MM)	PLY QUANTITY /APPL. TO
2	L11	0°			1
1	L06	90°			1
1	L05	0°			1
1	L04	90°			1
1	L03	0°			1
1	L02	90°			1
1	L01	0°			1

LAY-UP PLAN

- ⚠ ITEM 4 TO BE BONDED AFTER ITEM 1 IS CURED;
 ⚠ ITEM 2 MUST BE 5MM MINIMUM WIDER THAN EXISTING CONDUCTIVE STRIPS BOTH SIDE.
 ⚠ ITEM 4 MUST OVERLAP 25MM MINIMUM WITH EXISTING CONDUCTIVE STRIPS.
 CONTACT AREA OF CONDUCTIVE STRIPS MUST BE FREE FROM FOREIGN MATERIALS.
 2. CURE LAMINATE USING VACUUM BAG (21Hg) AT ROOM TEMPERATURE FOR 24 HOURS.
 1. LAY-UP ITEMS 1 AND 2 USING ADHESIVE
- NOTES

Figure 6 Roof Reinforcement PRE AMS OP-3560 - Composite Layup

Transport Canada - Accepted

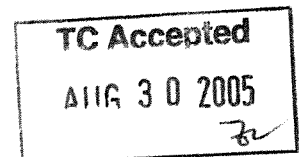

10. PLACARDS AND MARKINGS

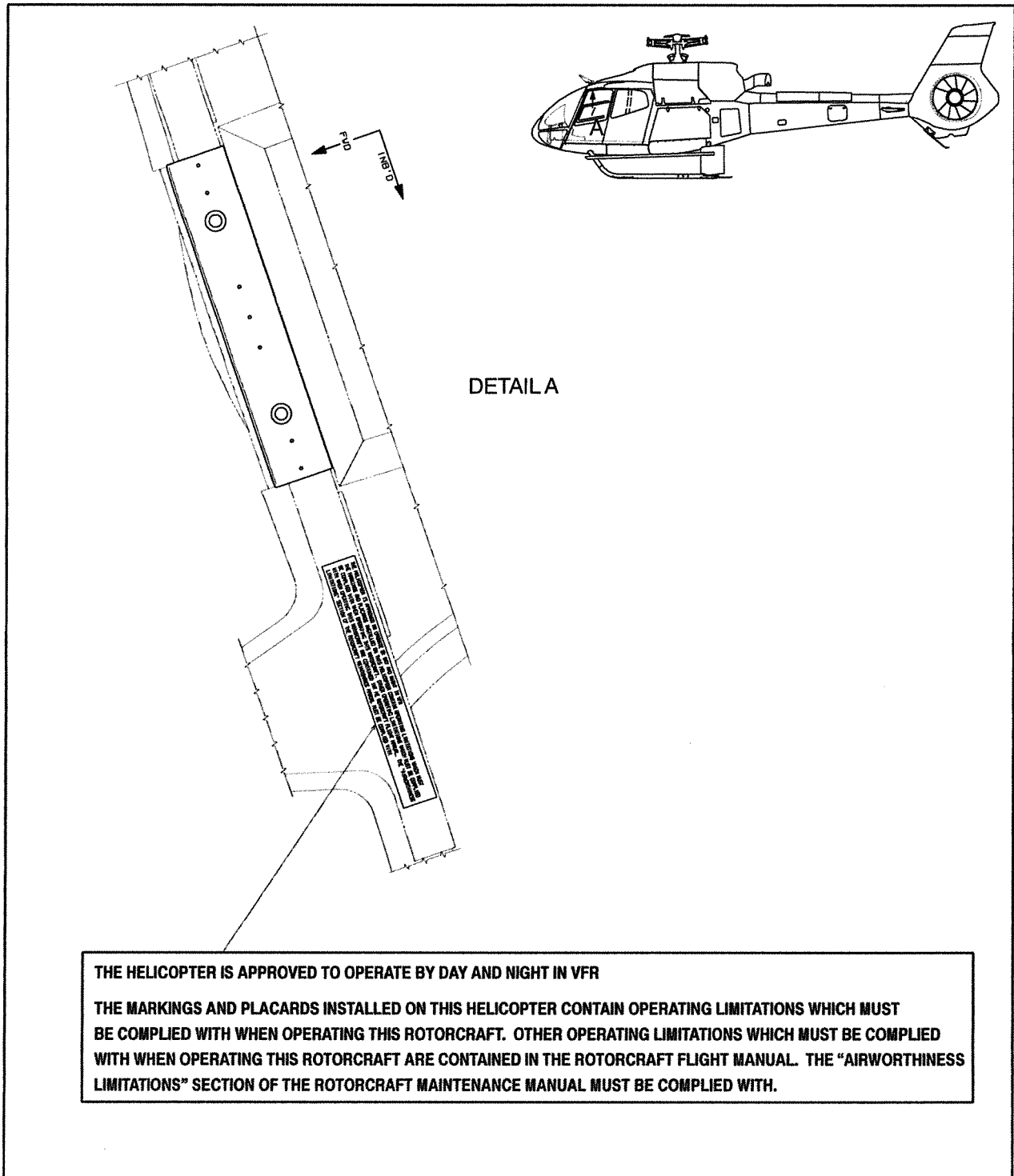

Figure 7 View showing relocated placard location on Overhead Panel

Transport Canada - Accepted

TC Accepted
AUG 30 2005
[Signature]



WIRE STRIKE PROTECTION SYSTEM

EUROCOPTER EC130 HELICOPTER

MAINTENANCE MANUAL SUPPLEMENT AND ILLUSTRATED PARTS LIST

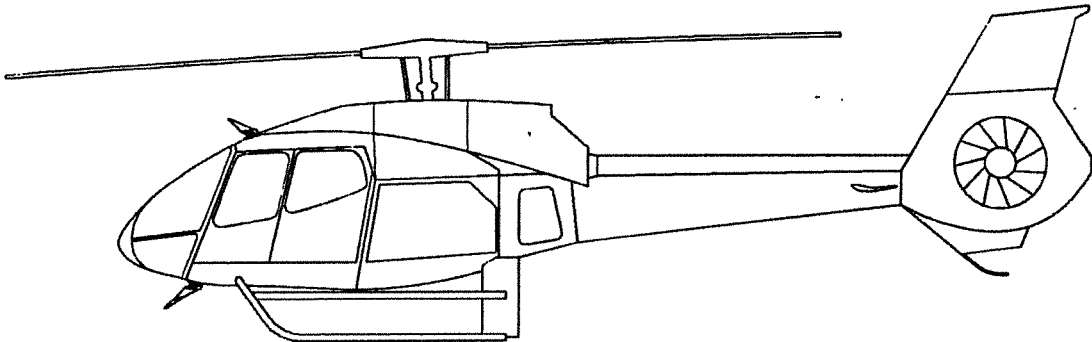

BRISTOL AEROSPACE LIMITED

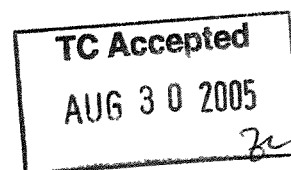

PM-965-054A

**This manual applies to
Bristol Aerospace Limited
WSPS® Kit 965-19701-001
for the
Eurocopter EC130 Helicopter**

WSPS® is a Registered Trade Mark of Bristol Aerospace Limited

TC Accepted

AUG 30 2005

72

CHANGE RECORD SHEET

ISSUE	CHANGE	BY	DATE	APPROVAL
A DR1008884	Original Issue	M. Bouchard <i>[Signature]</i> D. DEESCHUM	03 Aug 2005 3 AUG 05	<i>[Signature]</i> 3 Aug 2005

TC Accepted
AUG 30 2005
[Signature]

This page intentionally left blank

TC Accepted
AUG 30 2005
[Handwritten signature]

Table of Contents

Section/Title	Page
1. Inspection	5
1.1 Pre-flight Inspection	5
1.2 Lower WSPS Ground Contact Inspection	5
1.3 Post Wire Strike Inspection	5
2. Maintenance.....	7
2.1 Consumable Materials Required for Maintenance	7
2.2 Preventive Maintenance.....	7
2.3 Inspection and Repair Procedures: Cutter Assemblies	7
2.4 Inspection and Repair Procedures: Cutter Blades	9
3. Illustrated Parts List.....	12
3.1 Upper Cutter Installation	12
3.2 Lower Cutter Installation	14

Table of Illustrations

Figure/Title	Page
Figure 1-1 EC130 WSPS Installation	6
Figure 2-1 Upper Cutter Installation	10
Figure 2-2 Lower Cutter Installation	11
Figure 3-1 Upper Cutter Breakdown	12
Figure 3-2 Lower Cutter Breakdown	14

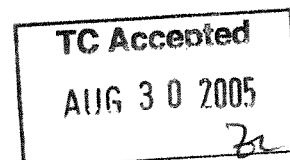

Preface

This manual contains inspection and maintenance procedures for the Bristol Aerospace Limited Eurocopter EC130 Helicopter Wire Strike Protection System (WSPS).

Operators and maintenance personnel should ensure that they are familiar with the contents of this manual. This manual should be kept in a safe and accessible location.

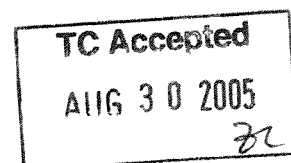

1. Inspection

All inspections are performed visually without magnification.

1.1 Pre-flight Inspection

Visually inspect the WSPS upper cutter and lower cutter for obvious damage or signs of deterioration. See Figure 1-1.

To check the security of the WSPS, apply hand pressure to the components to check for looseness. If any looseness is evident, re-torque or replace mounting screws.

1.2 Lower WSPS Ground Contact Inspection

In case of lower WSPS ground contact, visually inspect the lower cutter for damage in accordance with section 2.3.

NOTE

The breakaway tip rivets are designed to shear in the event of ground contact. Replace the entire breakaway tip if damaged or loose rivets are found.

1.3 Post Wire Strike Inspection

After an observed or suspected wire strike:

- a. Visually inspect the aircraft and external components for damage and repair in accordance with helicopter manufacturer's recommendations.
- b. Visually inspect the WSPS components for damage in accordance with sections 2.3 to 2.4.
- c. Replace cutter blades involved in wire strike.

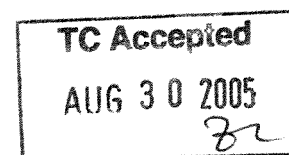

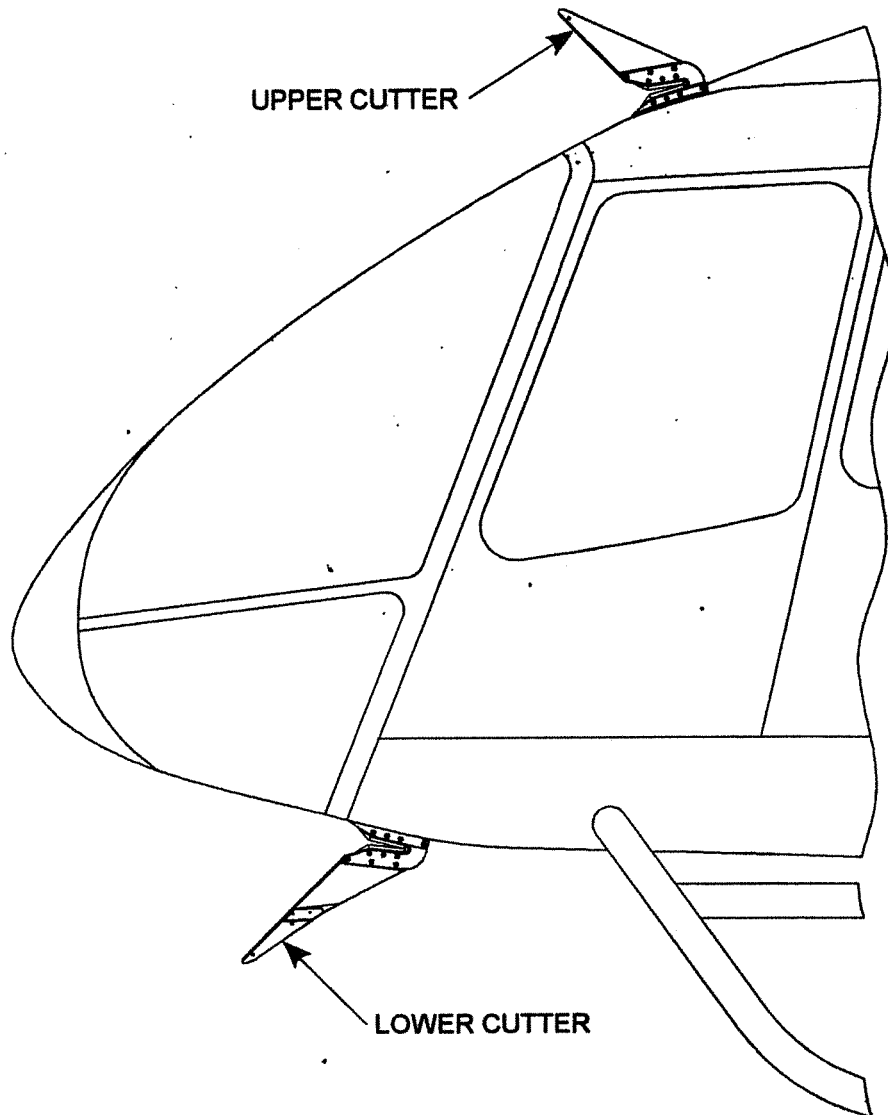

Figure 1-1 EC130 WSPS Installation

TC Accepted
AUG 30 2005
ZL

2. Maintenance

WARNING

All hardware used on the WSPS is of approved aircraft grade. Bristol Series 990 screws are heat treated to withstand projected cutting and impact loads and should not be replaced with any other type of screw.

Maintenance procedures for WSPS will fall into two basic categories: preventative maintenance to offset deterioration caused by time or weather, and corrective procedures to repair units damaged through accidents.

NOTE

Refer to rotorcraft maintenance manuals to prepare aircraft for maintenance. Follow all safety measures referred to in the manual.

2.1 Consumable Materials Required for Maintenance

The following table lists the recommended materials for maintenance of the WSPS.

COSUMABLE	TYPE	SPECIFICATION *
Abrasive Cloth Sandpaper	180-320 Grit	N/A
Primer	Epoxy Polyamide	MIL-PRF-23377 Type I Class C
Paint	As Applicable.	As Applicable
Chemical Conversion Coating (Alodine)	Brush or Immersion	MIL-C-5541 Class 1A
Sealant	Sealing and Coating Compound, Corrosion Inhibitive	MIL-S-81733 Type II, Class 1, Grade A

* Equivalent materials may be substituted

2.2 Preventive Maintenance

2.2.1 Inspect condition and security of WSPS cutter assemblies. Minor nicks and scratches to components may be dressed out, with the exception of cutter blades. Replace any cracked or deformed components. Re-torque loose fasteners or replace if damaged.

2.2.2 Inspect cutter blades for any deformation, corrosion, nicks, scratches, cracks, or gouges. Blades showing evidence of any type of damage must be replaced. Damaged or missing rubber coating may be repaired using approved sealant.

2.2.3 Inspect and verify that lower cutter breakaway tip is secure. Replace tip and rivets if the rivets are loose or damaged.

2.2.4 Inspect all components for surface finish deterioration and/or corrosion damage. Refinish areas where surface paint has been removed or damaged. Components showing evidence of light or moderate corrosion may be repaired and refinished, except cutter blades, which must be replaced. Replace components showing signs of heavy corrosion.

NOTE: Evaluate corrosion as follows:

Light corrosion: characterized by discoloration or pitting to a depth of approximately 0.02 mm maximum.

Moderate corrosion: appears similar to light corrosion except pitting depth may be as deep as 0.25 mm.

Heavy corrosion: general appearance may be similar to moderate corrosion with blistering, exfoliating, scaling or flaking. Pitting depths will be deeper than 0.25 mm.

2.3 Inspection and Repair Procedures: Cutter Assemblies

2.3.1 Inspection:

- a. Inspect the assembly for paint deterioration, superficial paint scratches, and corrosion. Heavy corrosion is not allowed. Scratches, nicks, or gouges to a depth of 0.25 mm may be repaired.
- b. Inspect the cutter blades as specified in section 2.4.

TC Accepted
AUG 30 2005
JL

- c. Inspect the deflector for cracks and permanent deformation. Deflectors showing evidence of any cracks or permanent deformation must be replaced.
- d. Check security of the cutter assembly. Retorque loose fasteners or replace if damaged.
- e. Inspect the surrounding support structure for evidence of permanent deformation. If permanent structural deformation exists, replace the entire cutter assembly and repair structure to manufacturer's specifications.

2.3.2 Removal:

2.3.2.1 Cutter Assemblies (Refer to Figure 2-1 and 2-2)

- a. Remove bolts securing cutter assembly to aircraft.
- b. Remove cutter assembly.
- c. Clean sealant from the cutter assembly and mounting structure.

2.3.2.2 Deflectors (Refer to Figure 2-1 and 2-2)

- a. Remove cutter assembly.
- b. Remove breakaway tip (applicable to lower cutter only, See 2.3.2.3)
- c. Remove nuts, washers, and screws securing deflector to cutter body and remove.
- d. Clean sealant from deflector and cutter body.

2.3.2.3 Breakaway Tip (Lower Cutter, Refer to Figure 2-2)

- a. Drill out rivets and drop tip free of cutter assembly.

2.3.2.4 Mounting Angle

- a. Remove cutter assembly.
- b. Remove nuts, washers, and screws securing mounting angles to cutter body and remove.
- c. Clean sealant from mounting angles and cutter body.

2.3.2.5 Cutter Bodies (Refer to Figure 2-1 and 2-2)

- a. Remove cutter assembly.
- b. Remove deflectors and mounting angles.
- c. Remove cutter blades. See Section 2.4.
- d. Clean sealant from deflectors, mounting

2.3.3 Repair: Clean and repair areas of light or moderate corrosion or deterioration on metal surfaces. Use sandpaper to remove scratches to a maximum depth of 0.25 mm. Alodine and prime bare metal, and paint superficial paint scratches.

2.3.4 Installation:

WARNING

All hardware used on the WSPS is of approved aircraft grade. Bristol Series 990 screws are heat treated to withstand projected cutting and impact loads and should not be replaced with any other type of screw.

2.3.4.1 Breakaway Tip (Lower Cutter, Refer to Figure 2-2.)

- a. Position breakaway tip on lower deflector and install rivets.

CAUTION

The breakaway tip rivets are designed to shear in the event of ground contact. Reinstall the same type of rivets.

- b. Prime and paint as required.

2.3.4.2 Deflectors (Refer to Figure 2-1 and 2-2)

- a. Apply sealant to deflectors and cutter body faying surfaces and install screws, washers, and nuts.
- b. Torque screws to 3.4-4.0 Nm (30-35 in lb).
- c. Clean off excess sealant.

2.3.4.3 Mounting Angles (Refer to Figure 2-1 and 2-2)

- a. Apply sealant to mounting angles and cutter body faying surfaces and install screws, washers, and nuts.
- b. Torque screws to 3.4-4.0 Nm (30-35 in lb).
- c. Clean off excess sealant.

2.3.4.4 Cutter Body (Refer to Figure 2-1 and 2-2)

- a. Install cutter blades. See Section 2.4.
- b. Install mounting angles and deflectors.
- c. Install cutter assembly.

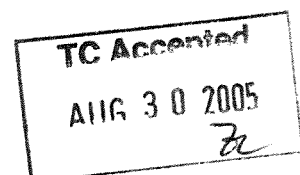

2.3.4.5 Cutter Assemblies (Refer to Figure 2-1 and 2-2)

- a. Apply sealant to cutter assembly faying surfaces.
- b. Position cutter assembly on aircraft and install bolts, washers, and nuts. Tighten bolts to required torque as specified in aircraft maintenance manual.
- b. Clean off excess sealant.
- c. Prime and paint as required.

- a. Apply sealant to the cutter blade(s) and position in cutter assembly.
- b. Install new capscrews, washers, and nuts. Check gap of aft portion of cutter throat blades. Maximum allowable gap is 0.5 mm with blades forced against the retaining screws. Torque screws to 3.4-4.0 Nm (30-35 in lb).

END

2.4 Inspection and Repair Procedures: Cutter Blades

2.4.1 Inspection:

- a. Inspect cutter blades for evidence of nicks, abrasions and shedding of rubber coating.

2.4.2 Removal: (Refer to Figure 2-1 and 2-2)

- a. Remove nuts, washers, and capscrews of blade to be removed.
- b. Remove cutter blade.
- c. Clean sealant from cutter body.

2.4.3 Repair:

NOTE:

Blades with nicks, abrasions, or corrosion on the cutting edge must be replaced.

- a. To repair damaged rubber coating, mask off cutter body on each side of cutter blades and apply a minimal coating of sealant to the cutter edge. Allow sealant to set before removing masking.
- b. Prime and paint as required.

2.4.4 Installation: (Refer to Figure 2-1 and 2-2)

WARNING

All hardware used on the WSPS is of approved aircraft grade. Bristol Series 990 screws are heat treated to withstand projected cutting and impact loads and should not be replaced with any other type of screw.

TC Accepted
AUG 30 2005
2

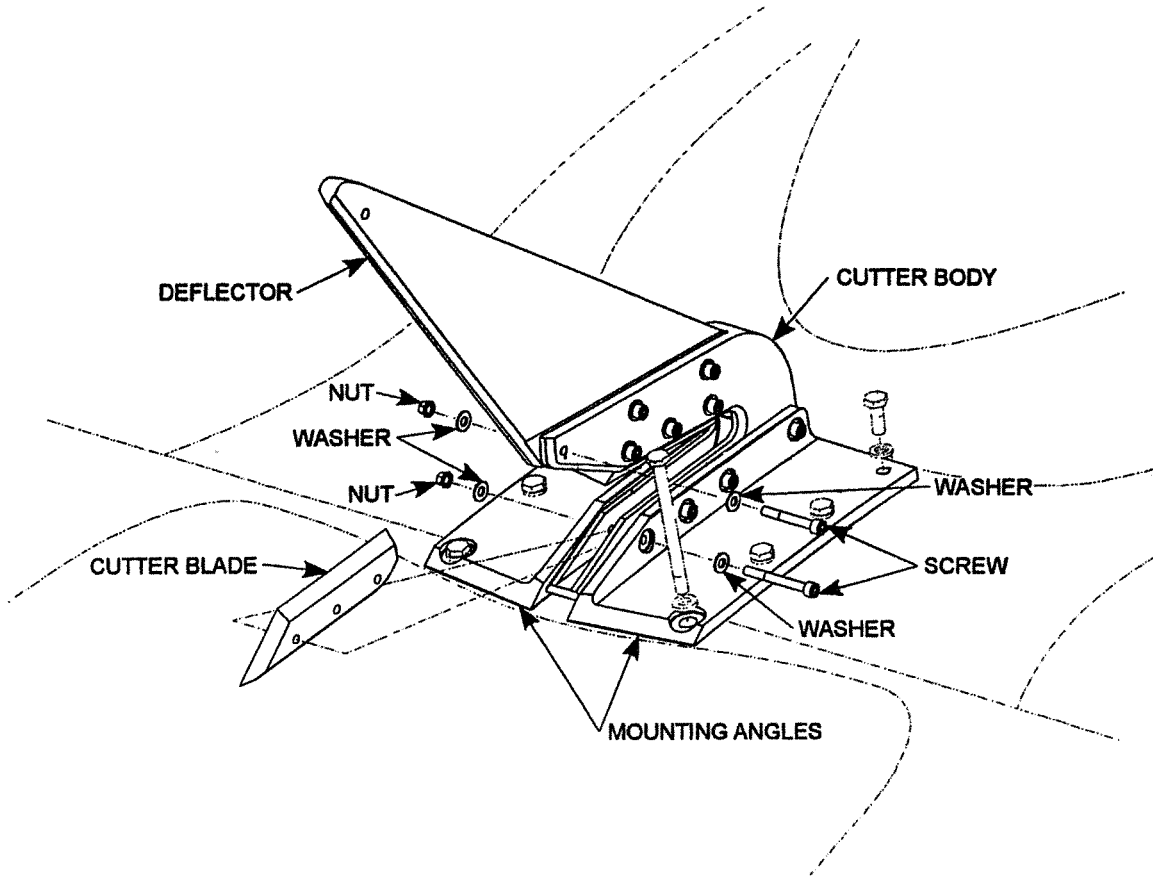

Figure 2-1 Upper Cutter Installation

TC Accepted
AUG 30 2005
31

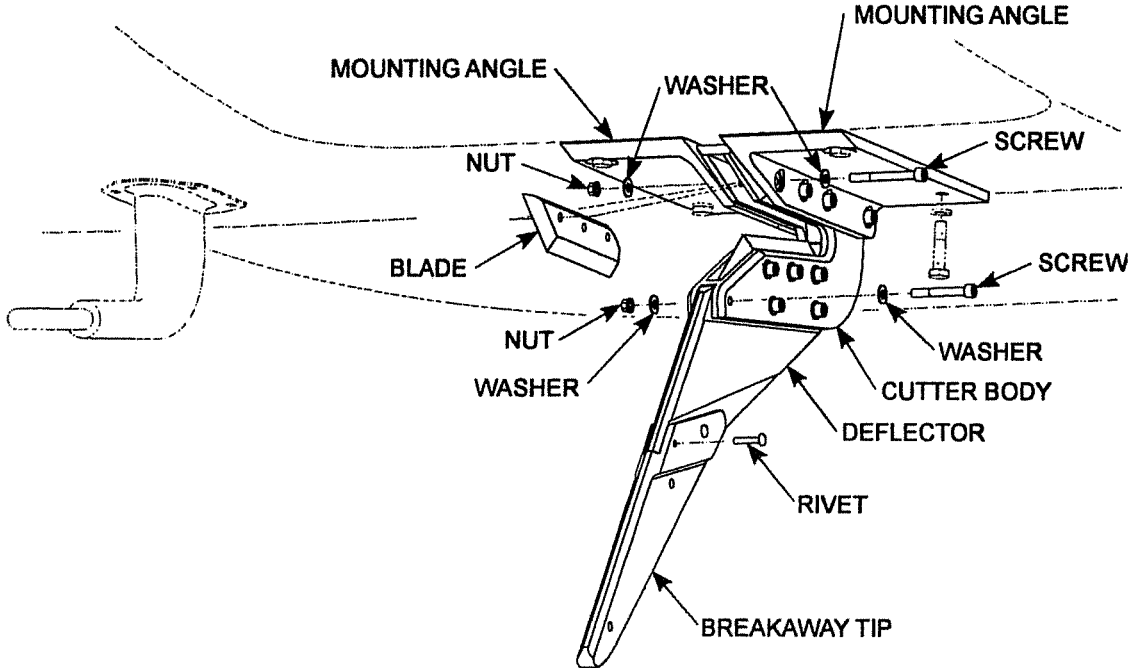

Figure 2-2 Lower Cutter Installation

TC Accepted
AUG 30 2005
72

3. Illustrated Parts List

3.1 Upper Cutter Installation

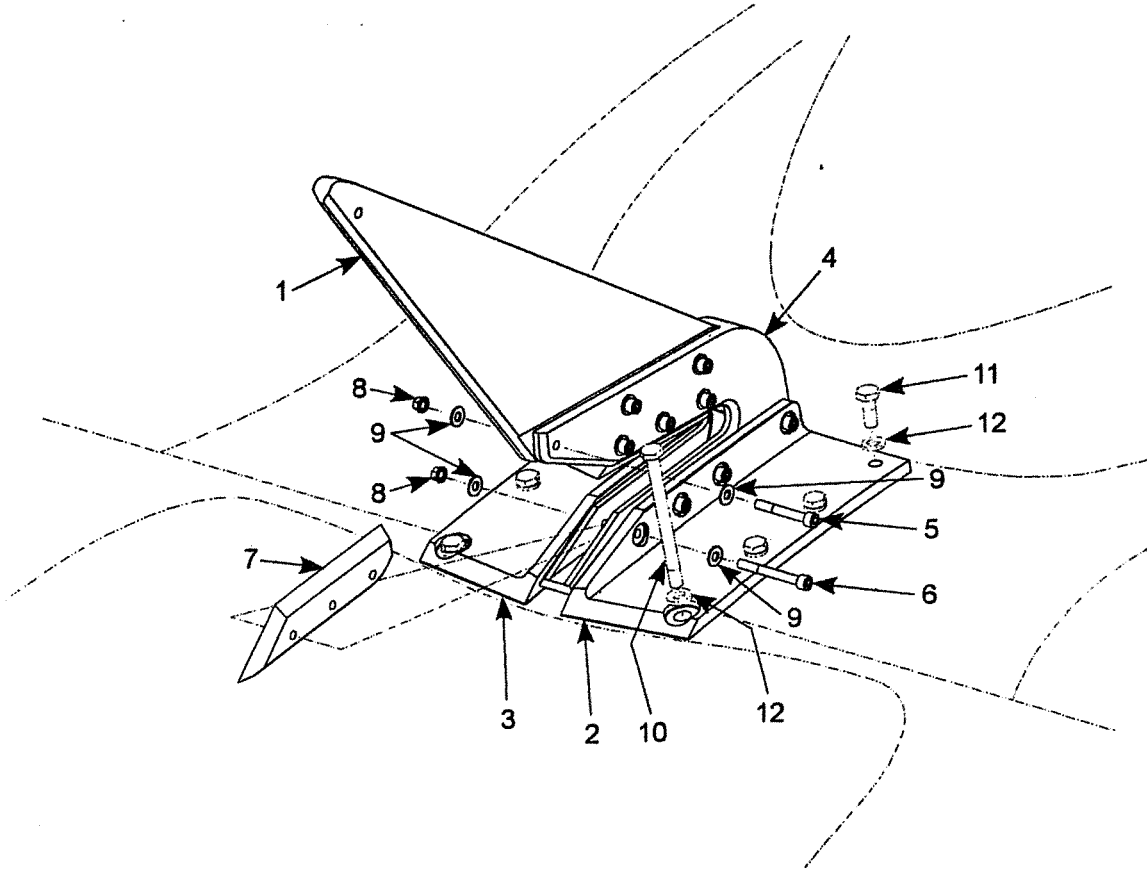

Figure 3-1 Upper Cutter Breakdown

TC Accepted
AUG 30 2005
72

**Indented Parts List
Eurocopter EC130
Wire Strike Protection System Installation**

Index Number	Wire Strike Protection System Upper Cutter Installation		UNITS PER A/C	NOTE
	PART NUMBER	NOMENCLATURE		
Fig. 3-1		Upper Cutter, Installation		
1	197-83001-1	• Upper Cutter Assembly	1	
2	197-83004-1	•• Deflector	1	
3	197-83006-1	•• Mounting Angle	1	
4	197-83006-2	•• Mounting Angle	1	
5	470-83005-1	•• Cutter Body	1	
6	990-00026-3	•• Screw	6	
7	990-00026-9	•• Screw	4	
8	990-00059-1	•• Blade	2	
9	MS21042L08	•• Nut	10	
10	NAS1149FN832P	•• Washer	20	
11		• Bolt	2	1
12		• Bolt	6	1
		• Washer	8	1
NOTE 1 - SUPPLIED BY EUROCOPTER				

TC Accepted

AUG 30 2005

3.2 Lower Cutter Installation

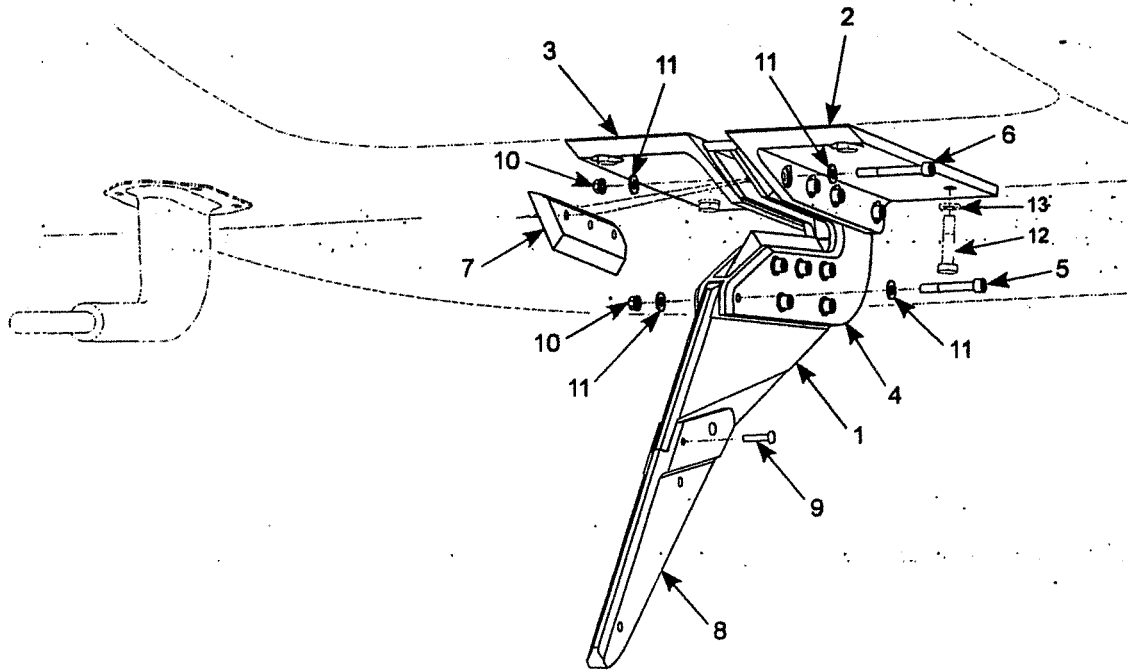

Figure 3-2 Lower Cutter Breakdown

TC Accepted
AUG 30 2005
JS

**Eurocopter EC130
Wire Strike Protection System Installation
Indented Parts List**

Index Number	Wire Strike Protection System Lower Cutter Installation		UNITS PER A/C	NOTE
	PART NUMBER	NOMENCLATURE		
Fig. 3-2		Lower Cutter, Installation	1	
	197-83002-1	• Lower Cutter Assembly	1	
1	197-83005-1	•• Deflector	1	
2	197-83007-1	•• Mounting Angle	1	
3	197-83007-2	•• Mounting Angle	1	
4	470-83005-1	•• Cutter Body	1	
5	990-00026-3	•• Screw	6	
6	990-00026-9	•• Screw	4	
7	990-00059-1	•• Blade	2	
8	990-00065-3	•• Breakaway Tip	1	
9	MS20470AD4-12	•• Rivet	2	
10	MS21042L08	•• Nut	10	
11	NAS1149FN832P	•• Washer	20	
12		•• Bolt	4	1
13		•• Washer	4	1
NOTE 1 - SUPPLIED BY EUROCOPTER				

TC Accepted
 AUG 30 2005
ZL