



EUROCOPTER CANADA LIMITED

SUBJECT:

These Instructions for Continued Airworthiness define the required maintenance for aircraft with the subject modification embodied.

Settling Protectors are designed to prevent the helicopter from sinking into soft ground. The settling protectors comprise LH and RH side pads and are installed at the aft end of the landing gear skid tubes.

APPLICABILITY:

SETTLING PROTECTORS (P/N 120-500214-01)

These Instructions for Continued Airworthiness are applicable to aircraft with the subject modification embodied.

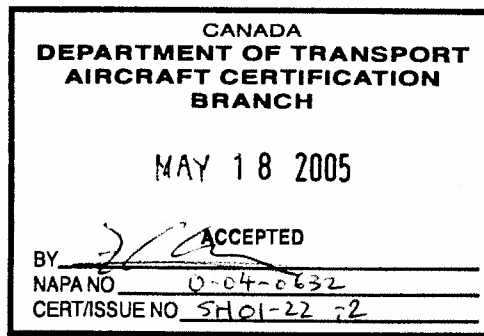

THE INFORMATION CONTAINED IN THIS DOCUMENT SHALL BE TREATED AS THE PROPERTY OF EUROCOPTER CANADA LIMITED (ECL). THE RECIPIENT OF THIS DOCUMENT SHALL NOT DISCLOSE ANY INFORMATION CONTAINED HEREIN TO THIRD PARTIES WITHOUT THE WRITTEN PERMISSION OF ECL, AND SHALL NOT USE OR REPRODUCE THIS DOCUMENT IN WHOLE OR IN PART FOR ANY PURPOSE OTHER THAN ITS ORIGINALLY INTENDED PURPOSE, OR TO EVALUATE ITS CONTENTS.

	NAME AND SIGNATURE	DATE	COMPANY DEPARTMENT
PREPARED BY:	D. Kerr <u>[Signature]</u>	17 May 2005	ECL ENGINEERING
PREPARED BY:			
CHECKED BY:	C. Timmins <u>[Signature]</u>	17 th May 2005	ECL ENGINEERING
CHECKED BY:	M. Merritt <u>[Signature]</u>	2005-05-18	ECL QUALITY ASSURANCE
APP'D / ACCEPTED (Civil A/W Authority)	(SEE TCCA STAMP)		TCCA
RELEASED BY:	R. Manson <u>[Signature]</u>	18 May 2005	ECL ENGINEERING



CONTENTS

SECTION	TITLE	PAGE
1	GENERAL	4
2	AIRWORTHINESS LIMITATIONS	6
3	CONTROL AND OPERATION	7
4	INSPECTION SCHEDULE AND MAINTENANCE ACTION	7
5	OVERHAUL REQUIREMENTS	7
6	TROUBLESHOOTING	8
7	SPECIAL TOOLING	6
8	REMOVAL AND REPLACEMENT	8
9	WEIGHT AND BALANCE DATA	9
10	PLACARDS AND MARKINGS	9

FIGURES

FIGURE	TITLE	PAGE
1	Settling Protector - Installation	4
2	Settling Protector - Details	10

TABLES

TABLE	TITLE	PAGE
1	Inspection Schedule	7

Transport Canada - Accepted

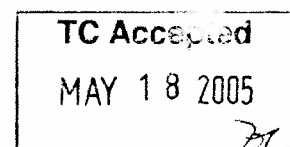

1. GENERAL

- A. Settling Protectors are designed to prevent the helicopter from sinking into soft ground during landing. The settling protectors comprise LH and RH side pads and are installed at the aft end of the landing gear skid tubes.

For instructions for initial installation, see IP-ECL-43.

- B. These Instructions for Continued Airworthiness are applicable to aircraft with the subject modification embodied.

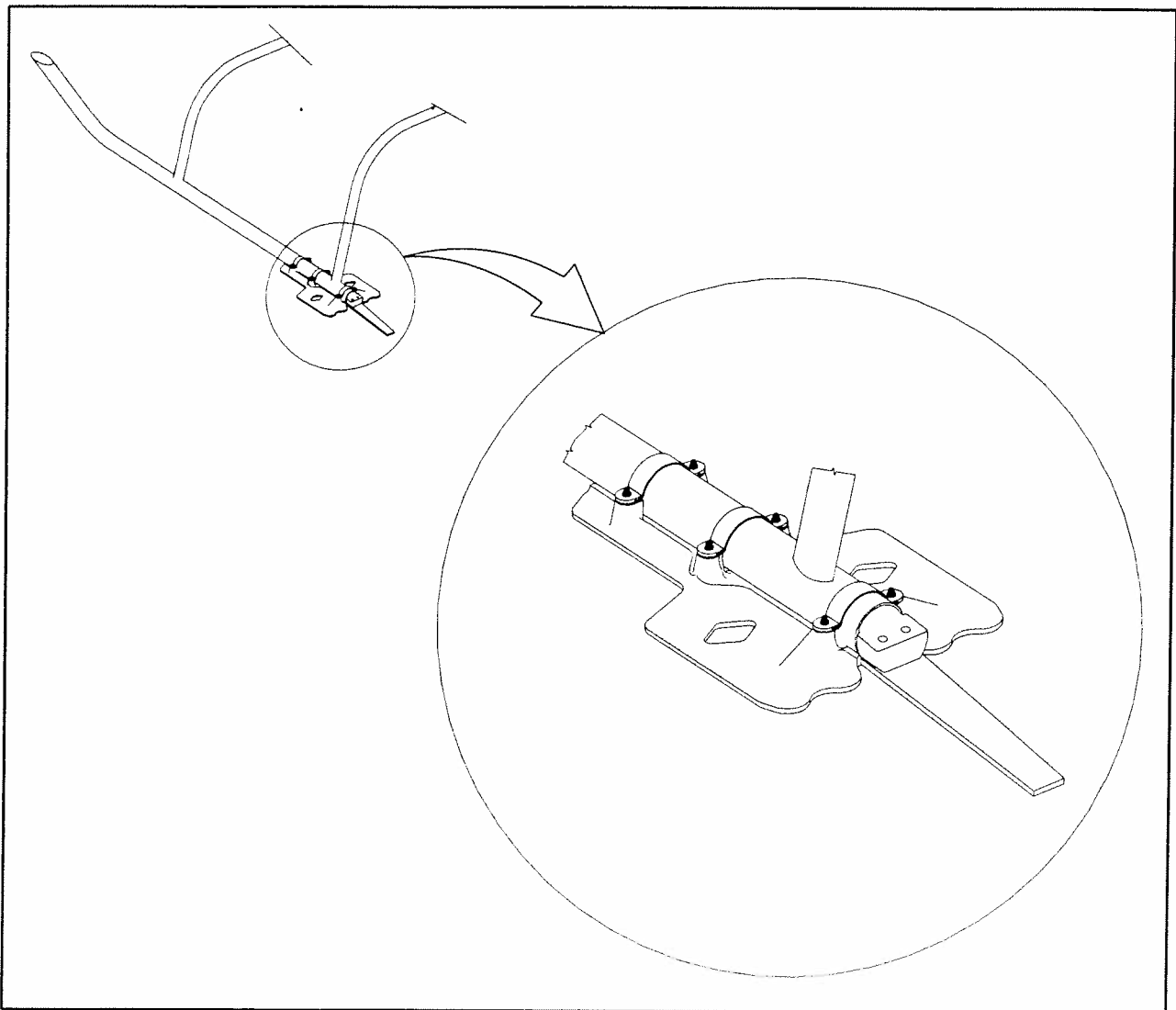
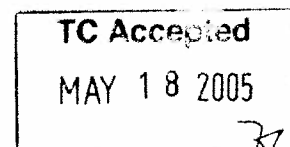

Figure 1 Settling Protectors - Installation
(LH shown, RH opposite)

Transport Canada - Accepted



C. REFERENCES

DOCUMENT	DOCUMENT TITLE
MTC	Standard Practices Manual
IP-ECL-43	Installation Procedure, Settling Protectors

D. ABBREVIATIONS & DEFINITIONS

ABBREVIATION	DEFINITION
P/N	Part Number
EC	Eurocopter (France)
ECL	Eurocopter Canada Limited
hrs	hours
LH	Left-Hand
RH	Right-Hand
FAA	Federal Aviation Administration

E. UNITS OF MEASUREMENT

ABBREVIATION / SYMBOL	UNIT OF MEASUREMENT
kg	kilogram
lbs	pounds
m	meter
in	inch
Nm	Newton meter

Transport Canada - Accepted

<p>TC Accepted MAY 18 2005 <i>72</i></p>

2. AIRWORTHINESS LIMITATIONS

The Airworthiness Limitations section is approved by the Minister and specifies maintenance required by any applicable airworthiness or operating rule unless an alternative program has been approved by the Minister.

No airworthiness limitations associated with this installation.

Transport Canada - Approved

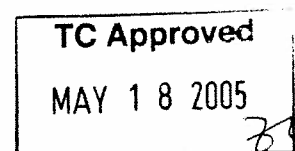

3. CONTROL AND OPERATION

There are no Control and Operation procedures required for maintenance.

4. INSPECTION SCHEDULE AND MAINTENANCE ACTION

Use torque per EC, MTC, Volume 2, Chapter 20.02.05.404, unless otherwise specified.

ITEM	INSPECTION OR MAINTENANCE WORK	INTERVAL	CORRECTIVE ACTION
A	- Visually inspect Settling Protector assembly for: a. cracks	Every 100 flight hrs or 12 months to coincide with the 100 hrs or 12 month helicopter inspection	a. No cracks are allowed. If cracks are found, contact ECL for replacement parts.
B	- Visually inspect settling protector assembly for wear a. If wear is within limit as defined in Figure 2 b. If wear is in excess of limit as defined in Figure 2	Every 100 flight hrs or 12 months to coincide with the 100 hrs or 12 month helicopter inspection	a. No action required b. Replace Settling Protector
C	- Visually inspect mounting hardware, items 20, 30, 40, and 50, in Figure 2 for: a. security b. thread deformity c. corrosion d. scoring	Every 100 flight hrs or 12 months to coincide with the 100 hrs or 12 month helicopter inspection	a. Re-tighten if required b. If thread deformity, is found, contact ECL for replacement parts. c. No corrosion is allowed. If corrosion is found, contact ECL for replacement parts. d. No scoring is allowed. If scoring is found, contact ECL for replacement parts.

Table 1 Inspection Schedule

5. OVERHAUL REQUIREMENTS

No overhaul requirements for this installation.

Transport Canada - Accepted

TC Accepted
MAY 18 2005
JL

EUROCOPTER CANADA LIMITED

6. TROUBLESHOOTING

There are no unique characteristics which require special troubleshooting techniques; standard techniques are adequate.

7. SPECIAL TOOLING

No special test equipment or tools are required. Standard tools are adequate.

8. REMOVAL AND REPLACEMENT

Proceed as follows if any of these items need to be removed.

Refer to Figure 2 for component removal and replacement.

A. REMOVAL

1) Settling Protectors

- a) With the helicopter parked on level ground, install ground handling wheels.

NOTE: Jack-up helicopter one side at a time, using ground handling wheels, for removal of the settling protectors.

- b) Remove nuts (50, Figure 2), washer (40), profile washer (30), and attachment clamps (20) and slide settling protectors (10) out in aft direction.

B. REPLACEMENT

1) Settling Protectors

NOTE: Use torque per EC, MTC, Volume 2, Chapter 20.02.05.404, unless otherwise specified.

- a) Park the helicopter on level ground and install the ground handling wheels.

NOTE: Jack-up helicopter one side at a time, using ground handling wheels, for installation of each settling protector.

- b) With one side of the helicopter raised, slide pre-assembled settling protector under the skid, and position in accordance with Figure 2.

NOTE: Do not remove existing skid plate.

- c) Slowly lower the helicopter to settle skid tube in settling protector.

- d) Install three clamps (20) and align the settling protector in accordance with Figure 2.

- e) Secure all clamps using profile washer (30), washer (40), nut (50), and hand tighten.

- f) Install the second settling protector in the same manner.

- g) With settling protectors installed on both sides, ensure that the helicopter is completely lowered, and the settling protectors are seated correctly.

- h) Remove ground handling wheels and torque all nuts (50) to secure the settling protectors to the skid tube.

NOTE: Torque clamp nuts (50) to 3 Nm to 5 Nm (26 in-lb to 44 in-lb), securing the Settling Protectors to the skid tube. If gaps exist, balance gap between each side of the clamp.

CAUTION: OVER TORQUING MAY DISTORT CLAMP OR BOLTS.

Transport Canada - Accepted

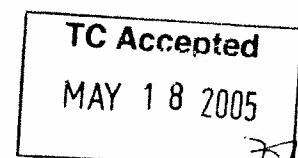



EUROCOPTER CANADA LIMITED

9. WEIGHT AND BALANCE DATA

a. Weight and Balance of Components Installed

DESCRIPTION	WEIGHT		ARM		MOMENT	
	kg	lbs	m	in	kg m	lb in
Settling Protector Installation	4.08	9.00	4.04	159.44	16.48	1434.96

b. Weight and Balance of Components Removed

Not applicable						
----------------	--	--	--	--	--	--

10. PLACARDS AND MARKINGS

Not Applicable

Transport Canada - Accepted

TC Accepted
MAY 18 2005
28

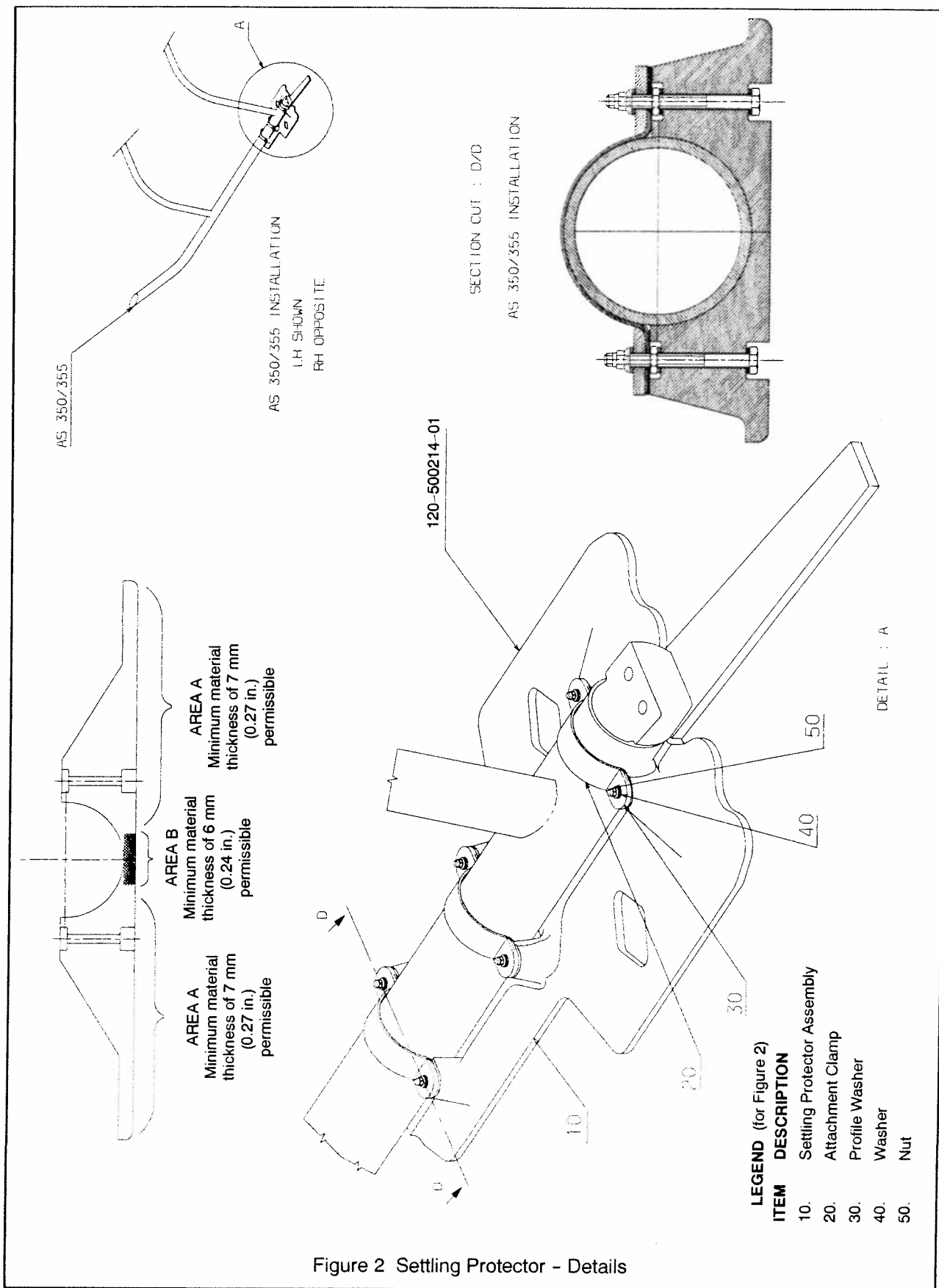

Figure 2 Settling Protector - Details

Transport Canada - Accepted

TC Accepted
MAY 18 2005
27