

SUBJECT:

Required maintenance for the RH Door Handle Installation (P/N 120-200014).

APPLICABILITY:

Aircraft with the subject modification embodied in accordance with TCCA STC. No. SH12-9 or any relevant foreign approvals.

THE INFORMATION CONTAINED IN THIS DOCUMENT SHALL BE TREATED AS THE PROPERTY OF EUROCOPTER CANADA LIMITED (ECL). THE RECIPIENT OF THIS DOCUMENT SHALL NOT DISCLOSE ANY INFORMATION CONTAINED HEREIN TO THIRD PARTIES WITHOUT THE WRITTEN PERMISSION OF ECL, AND SHALL NOT USE OR REPRODUCE THIS DOCUMENT IN WHOLE OR IN PART FOR ANY PURPOSE OTHER THAN ITS ORIGINALLY INTENDED PURPOSE, OR TO EVALUATE ITS CONTENTS.

	NAME AND SIGNATURE	DATE	COMPANY / DEPARTMENT
PREPARED BY:	D. Kerr <i>D. Kerr</i>	2 May 2011	ECL ENGINEERING
PREPARED BY:			ECL ENGINEERING
CHECKED BY:	C. Timmins <i>C. Timmins</i>	2 nd May 2011	ECL ENGINEERING
CHECKED BY:	M. Merritt <i>M. Merritt</i>	2011-05-02	ECL QUALITY ASSURANCE
APP'D / ACCEPTED (Civil A/W Authority)	<i>C. Timmins</i> (As per ICA Compliance Check Sheet)	10 th Feb 2012	TCCA
RELEASED BY:	R. Manson <i>R. Manson</i>	10 Feb 2012	ECL ENGINEERING



RECORD OF REVISIONS

Rev.	Pages at this Revision	Description, Reason, Changed Pages	Prepared (name and date)	Checked (name and date)	App'd/Acc'd (Civil A/W Authority) (name and date)	Released (name and date)
0	1 through 11	Original Issue	See page 1.	See page 1.	See page 1.	See page 1.

NOTE: Revisions to this document will be distributed to operators of this equipment by the STC holder.
NOTE: Revised portions of affected pages are identified by a vertical black line in the margin adjacent to the change.

Transport Canada - Accepted

CONTENTS

SECTION	TITLE	PAGE
1	GENERAL	4
2	AIRWORTHINESS LIMITATIONS	8
3	CONTROL AND OPERATION	9
4	INSPECTION SCHEDULE AND MAINTENANCE ACTION	9
5	REPLACEMENT COMPONENTS AND REPAIR/OVERHAUL INFORMATION ..	10
6	TROUBLESHOOTING	10
7	SPECIAL TOOLING	10
8	REMOVAL AND REPLACEMENT	10
9	WEIGHT AND BALANCE DATA	11
10	PLACARDS AND MARKINGS	11

FIGURES

FIGURE	TITLE	PAGE
1	General Layout	4
2	Door Handle Details (Sheet 1 of 2)	5
3	Door Handle Details (Sheet 2 of 2)	6

TABLES

TABLE	TITLE	PAGE
1	Inspection Schedule and Maintenance Action Every 100 flight hrs or 12 months	9
2	Inspection Schedule and Maintenance Action Every 500 flight hrs or 24 months	9

Transport Canada - Accepted

1. GENERAL

- A. The subject RH Door Handle Installation is installed on the inside of the forward right-hand door providing the crew member a convenient and easily accessible means of closing the RH Door.

The RH Door Handle is manufactured from high performance thermoplastic (PEI). Two door reinforcements are secured to the door channel. Two spacers are attached to the outer door reinforcement which can be adjusted to achieve the correct fit for the door handle once the door side panel is attached.

The RH Door Handle Installation consists of the following main components:

Fixed Provisions:

- inner door reinforcement
- outer door reinforcement
- spacer

Detachable Provisions:

- door handle

- B. The Instructions for Continued Airworthiness are applicable to aircraft with the subject modification embodied.

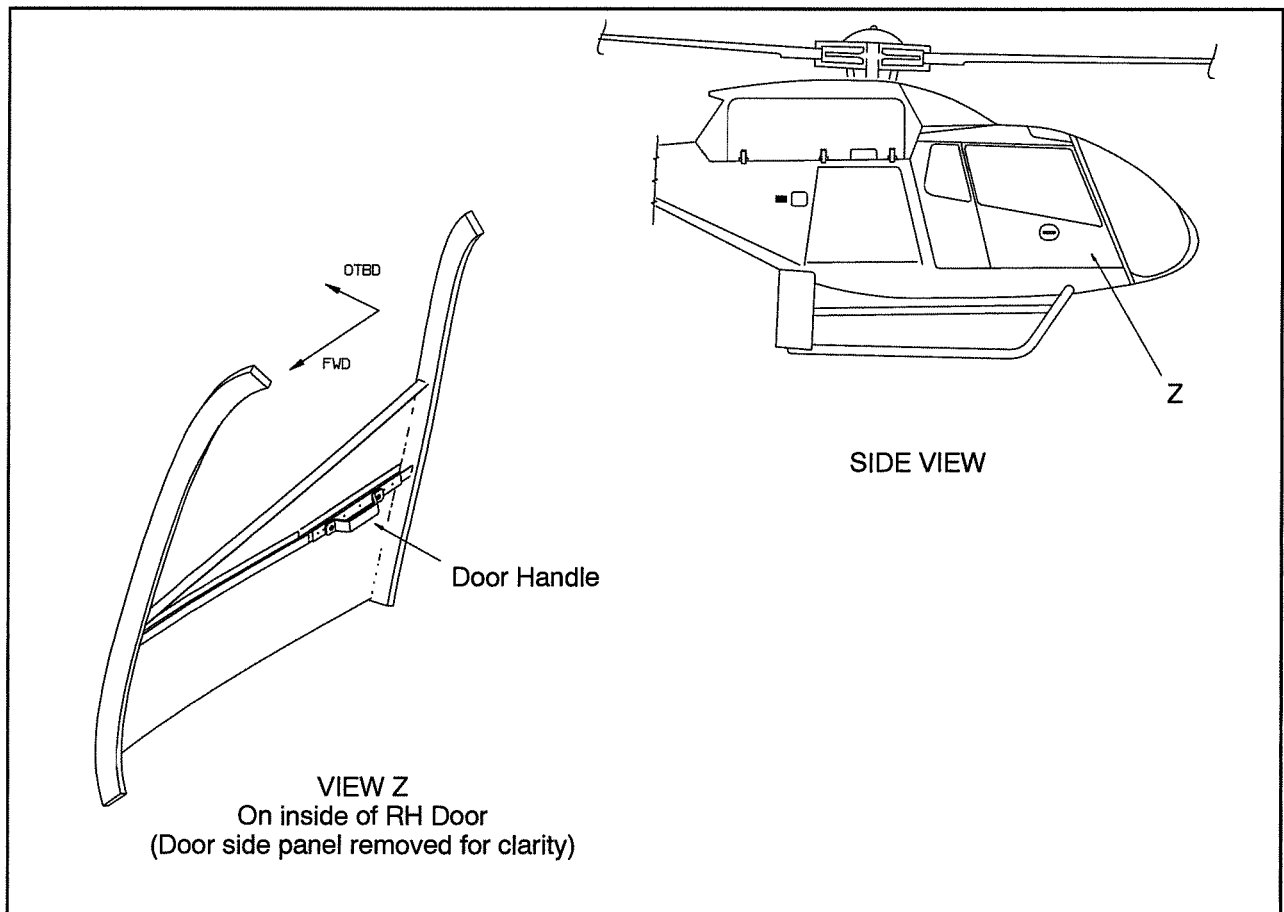

Figure 1 General Layout

Transport Canada Accepted

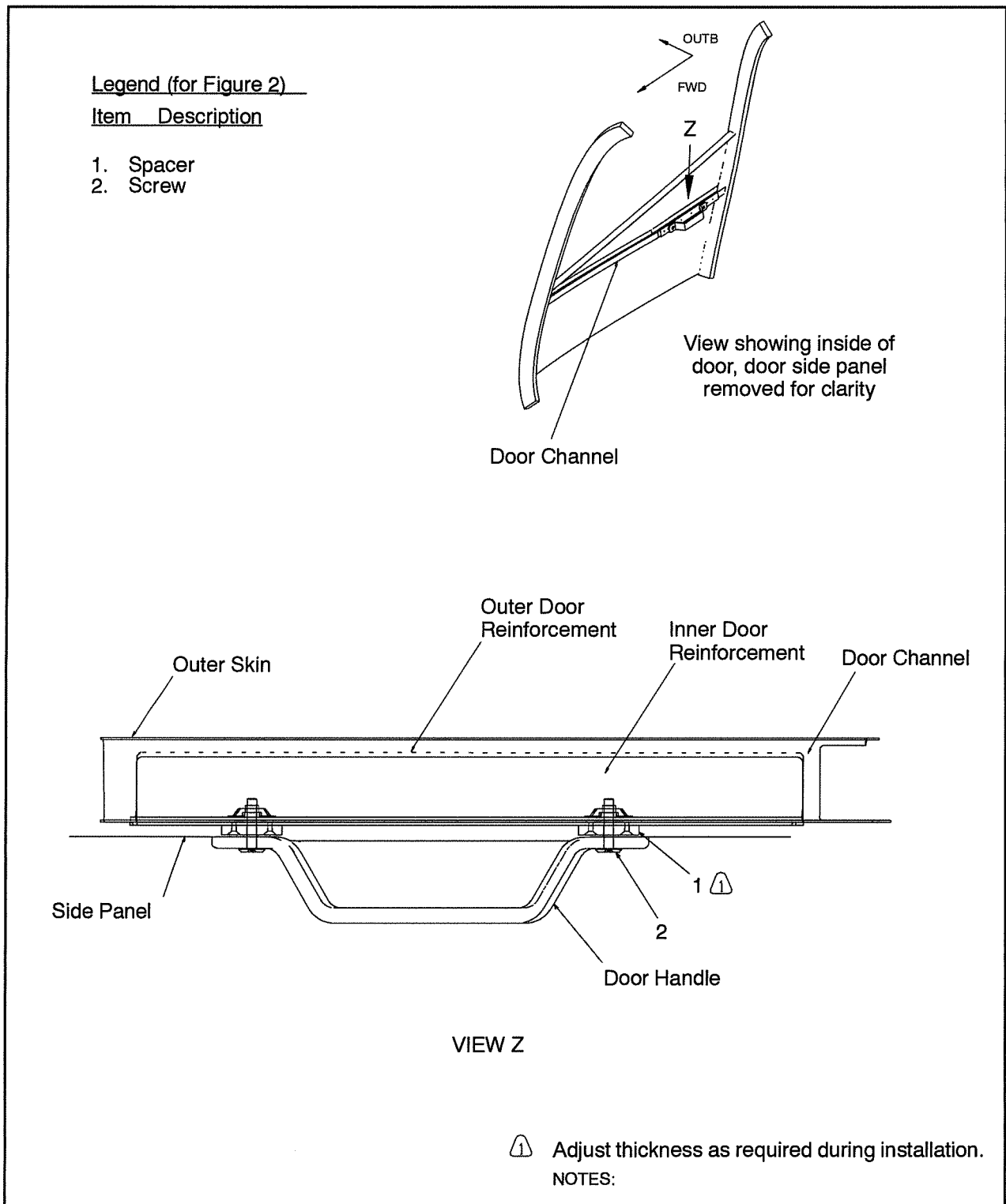

Figure 2 Door Handle Details (Sheet 1 of 2)

Transport Canada Accepted

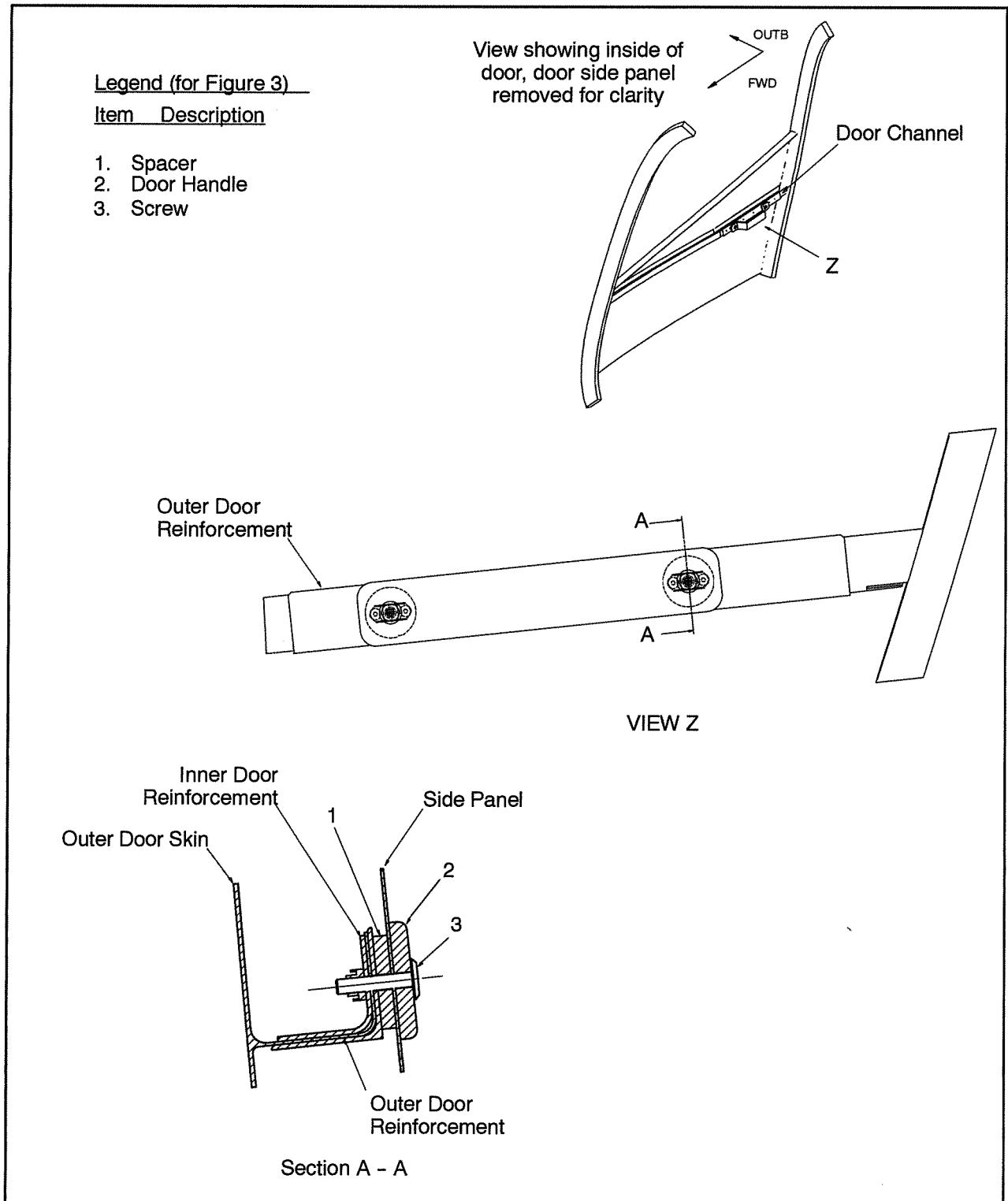

Figure 3 Door Handle Details (Sheet 2 of 2)

Transport Canada Accepted

C. REFERENCES

DOCUMENT	DOCUMENT TITLE
AMM	Aircraft Maintenance Manual

D. ABBREVIATIONS & DEFINITIONS

ABBREVIATION	DESCRIPTION
EC	Eurocopter (France)
ECL	Eurocopter Canada Limited
FWD	Forward
OTBD	outboard
qty.	quantity
PEI	polyetherimide
RH	Right-hand

E. UNITS OF MEASUREMENT

ABBREVIATION / SYMBOL	UNIT OF MEASUREMENT
hrs	hours
in	inch
kg	kilogram
lb	pound
m	meter

Transport Canada Accepted

2. AIRWORTHINESS LIMITATIONS

The Airworthiness Limitations section is approved by the Minister and specifies maintenance required by any applicable airworthiness or operating rule unless an alternative program has been approved by the Minister.

No airworthiness limitations associated with this installation.

Transport Canada Approved

3. CONTROL AND OPERATION

Control and operation of the aircraft remains unchanged.

4. INSPECTION SCHEDULE AND MAINTENANCE ACTION

NOTE: Use torque per EC 120 AMM, Volume 1, Chapter 20-10-00, 3-2, unless otherwise specified.

4.1. INSPECTION SCHEDULE

4.1.1. Every 100 flight hrs or 12 months (to coincide with the 100 hrs or 12 month helicopter inspection)

ITEM	INSPECTION OR MAINTENANCE WORK	CORRECTIVE ACTION
A	- Visually inspect door handle, in Figure 2 for: a. security	a. Secure as required.
B	- Visually inspect door handle in Figure 2 for: a. cracking	a. Cracking is not permitted. If cracking is evident, contact ECL for replacement part.
C	- Visually inspect RH side panel, shown in Figure 3 for: a. cracking around door handle attachment points	a. Cracking is not permitted. If cracking is evident, replace side panel in accordance with EC, Aircraft Maintenance Manual (AMM), Chapter 25-23-00, 4-1. Contact ECL for replacement part.

Table 1 Inspection Schedule and Maintenance Action
Every 100 flight hrs or 12 months

4.1.2. Every 500 flight hrs or 24 months (to coincide with the 500 hrs or 24 month helicopter inspection)

ITEM	INSPECTION OR MAINTENANCE WORK	CORRECTIVE ACTION
A	- Visually inspect outer reinforcement panel, inner reinforcement panel and spacer, shown in Figure 3. a. cracking b. corrosion	a. No cracking is allowed. If cracking is found, contact ECL for replacement part. b. No corrosion is allowed. If corrosion is found, contact ECL for replacement part.

Table 2 Inspection Schedule and Maintenance Action
Every 500 flight hrs or 24 months

Transport Canada Accepted

5. REPLACEMENT COMPONENTS AND REPAIR/OVERHAUL INFORMATION

No replacement components and repair/overhaul information required for this installation.

6. TROUBLESHOOTING

There are no unique characteristics which require troubleshooting techniques.

7. SPECIAL TOOLS

No special test equipment or tools are required. Standard tools are adequate.

8. REMOVAL AND REPLACEMENT

Proceed as follows if any of these items need to be removed:

PRELIMINARIES

- Read General Safety Instructions - Electrical Power Supply System (refer to EC 120 B, Aircraft Maintenance Manual, Chapter 24-00-00, 3-1).
- Disconnect external power unit and the battery (refer to Removal/Installation - Battery, EC 120 B, Aircraft Maintenance Manual, Chapter 24-33-00, 4-1).

A. REMOVAL

- 1) DOOR HANDLE (Refer to Figure 3)
 - a) Remove screws (3) (2 places) that secure the door handle to the inside of the RH Door.
 - b) Remove the door handle.

B. REPLACEMENT

NOTE: Use torque per EC 120 AMM, Volume 1, Chapter 20-10-00, 3-2, unless otherwise specified.

- 1) DOOR HANDLE(Refer to Figure 3)
 - a) Reposition the door handle onto the inside of the RH door over the previously drilled holes.
 - b) Secure door handle using screws (3) (2 places).
- 2) Close all areas opened for service in the PRELIMINARIES paragraph of this section.
- 3) Apply external power unit and battery. Refer to Removal/Installation - Battery, EC 120 B, Aircraft Maintenance Manual, Chapter 24-33-00, 4-1.
- 4) Perform functional tests in accordance with EC 120 B, Aircraft Maintenance Manual, Chapter 24-33-00, 5-1.

Transport Canada Accepted

9. WEIGHT AND BALANCE DATA

A. Removed Items

DESCRIPTION	WEIGHT		ARM		MOMENT	
	kg	lbs	m	in	kg m	lb in
(not applicable)	0.00	0.0	0.00	0.0	0.00	0.0
Total	0.00	0.0	0.00	0.0	0.00	0.0

B. Added Items

DESCRIPTION	WEIGHT		ARM		MOMENT	
	kg	lbs	m	in	kg m	lb in
Door Handle (qty. 1)	0.13	0.3	2.97	116.9	0.37	35.1
Spacer (qty. 2)	0.03	0.1	2.97	116.9	0.08	11.7
Outer Door Reinforcement	0.12	0.3	2.97	116.9	0.35	35.1
Inner Door Reinforcement	0.10	0.2	2.97	116.0	0.29	23.4
Total	0.37	0.9	2.97	116.9	1.09	105.2

10. PLACARDS AND MARKINGS

There are no placards or markings with this modification.

Transport Canada Accepted