



SUBJECT:

Required maintenance for the Blade Tie-Down Kit (P/N 350-700414 and 130-700414).

APPLICABILITY :

Aircraft with the subject modification embodied in accordance with TCCA STC No. SH96-126 or any relevant foreign approvals.

THE INFORMATION CONTAINED IN THIS DOCUMENT SHALL BE TREATED AS THE PROPERTY OF EUROCOPTER CANADA LIMITED (ECL). THE RECIPIENT OF THIS DOCUMENT SHALL NOT DISCLOSE ANY INFORMATION CONTAINED HEREIN TO THIRD PARTIES WITHOUT THE WRITTEN PERMISSION OF ECL, AND SHALL NOT USE OR REPRODUCE THIS DOCUMENT IN WHOLE OR IN PART FOR ANY PURPOSE OTHER THAN ITS ORIGINALLY INTENDED PURPOSE, OR TO EVALUATE ITS CONTENTS.

	NAME AND SIGNATURE	DATE	COMPANY DEPARTMENT
PREPARED BY:	D. Kerr <i>D. Kerr</i>	4 June 2012	ECL ENGINEERING
PREPARED BY:			
CHECKED BY:	C. Timmins <i>C. Timmins</i>	4 th June 2012	ECL ENGINEERING
CHECKED BY:	M. Merritt <i>M. Merritt</i>	2012-06-04	ECL QUALITY ASSURANCE
APPROVED / ACCEPTED (Civil A/W Authority)	(As per ICA Compliance Check Sheet) G. DAVID <i>G. David</i>	2012.06.11	TCCA
RELEASED BY:	R. Manson <i>R. Manson</i>	14 Jun 2012	ECL ENGINEERING



RECORD OF REVISIONS

Rev.	Pages at this Revision	Description, Reason Changed Pages	Prepared (name and date)	Checked (name and date)	App'd/Acc'd (Civil A/W Authority) (name and date)	Released (name and date)
0	1 through 19	Original Issue	D. Kerr 11 November 2011	C. Timmins 11 November 2011	N/A	R. Manson 16 May 2012
1	1 through 23	Addition of 150 flight hr inspection and Supplemental Maintenance Instructions if used in winds exceeding 40 knots. Sealant P/N corrections. Addition of Removal/Replacement instructions. Correction to EC 130 Weight & Balance Chart. New Warning Flag attached to Tie-Down Rope Assembly. (Pages 3, 5, 6, 9, 10, 12, 14 to 20, 22 & 23)	See page 1.	See page 1.	See page 1.	See page 1.

NOTE: Revisions to this document will be distributed to operators of this equipment by the STC holder.
NOTE: Revised portions of affected pages are identified by a vertical black line in the margin adjacent to the change.

Transport Canada Accepted

CONTENTS

SECTION	TITLE	PAGE
1	GENERAL	4
2	AIRWORTHINESS LIMITATIONS	13
3	CONTROL AND OPERATION	14
4	INSPECTION SCHEDULE AND MAINTENANCE ACTION	14
5	REPLACEMENT COMPONENTS AND REPAIR / OVERHAUL INFORMATION	18
6	TROUBLESHOOTING	18
7	SPECIAL TOOLING	18
8	REMOVAL AND REPLACEMENT	19
9	WEIGHT AND BALANCE DATA	21
10	PLACARDS AND MARKINGS	22

FIGURES

FIGURE	TITLE	PAGE
1	General Layout	4
2	AS 350 / AS 355 / EC 130 Details	5
3	AS 350 / AS 355 Forward Fixed Provisions	6
4	AS 350 / AS 355 Aft Fixed Provisions	7
5	AS 350 / AS 355 Detachable Provisions	8
6	EC 130 Forward Fixed Provisions	9
7	EC 130 Aft Fixed Provisions	10
8	EC 130 Detachable Provisions	11
9	Typical location of Warning Flag on Tie-Down Rope Assembly	23

TABLES

TABLE	TITLE	PAGE
1	Before each installation	14
2	Every 150 flight hrs or 12 months (to coincide with the 150 hrs or 12 months helicopter inspection), whichever occurs first	15
3	Inspection Schedule and Maintenance Action Every 600 flight hrs or 24 months, whichever occurs first	15
4	Supplemental Maintenance Instructions	17

Transport Canada - Accepted

1. GENERAL

- A. The Blade Tie-Down Kit consists of fixed and detachable provisions. A detachable rod assembly is secured to each modified blade tracking finger with an attached rope securing the opposite end to the aircraft by means of a snap hook. Forward and aft brackets are mounted to the aircraft providing secure attachment locations for the snap hook. Refer to Figure 1 for General Layout.

Tracking fingers that can be modified must have a part number given below:
AS 350 Tracking Finger Part Number - 350A11-1248-20 or 355A11-2013-20
AS 355 Tracking Finger Part Number - 355A11-2013-20
EC 130 Tracking Finger Part Number - 355A11-2013-20

The Blade Tie-Down Kit is for ground parking and mooring protection.

For instructions of initial installation, see IP-ECL-132.

- B. These Instructions for Continued Airworthiness are applicable to aircraft with the subject modification embodied.

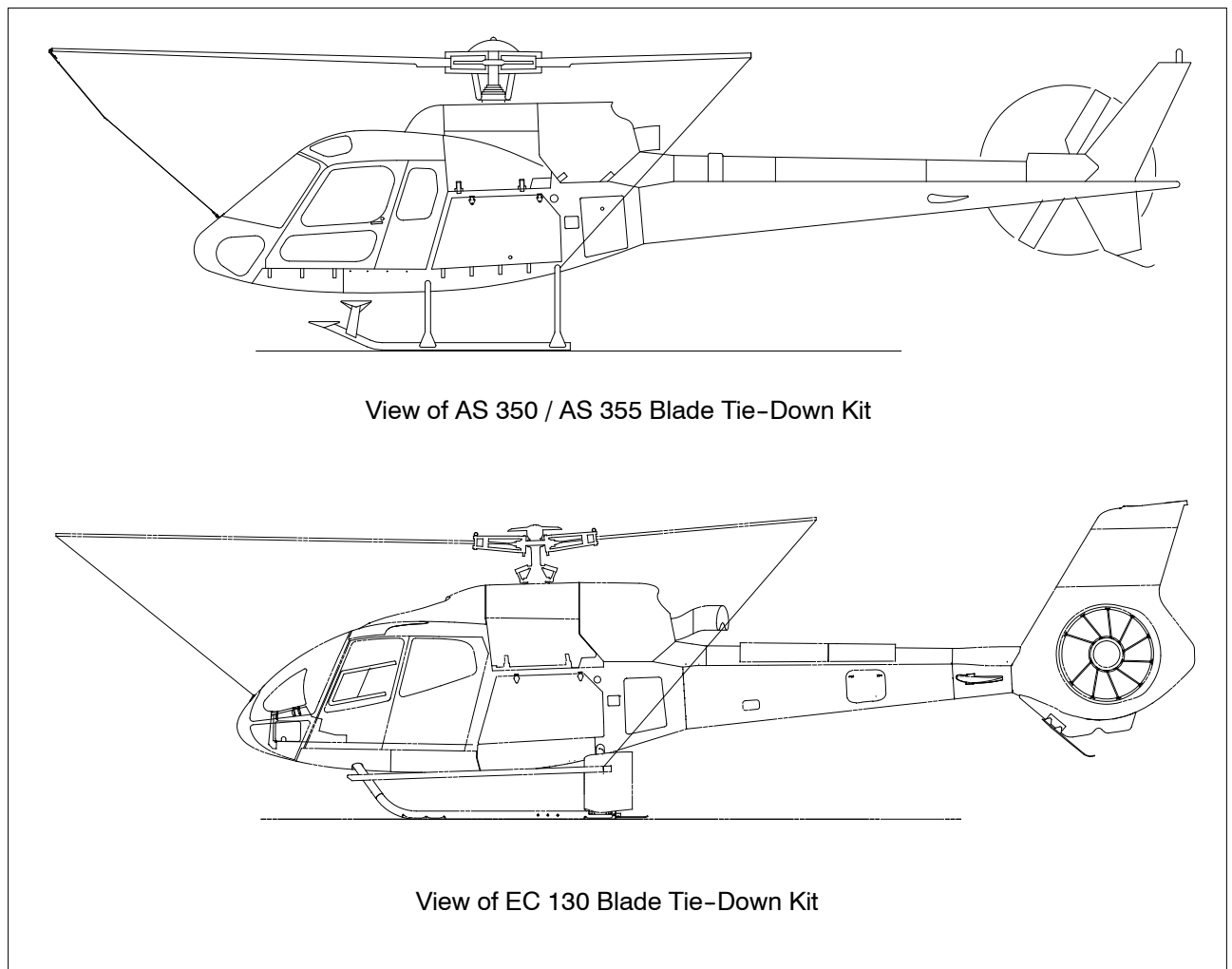

View of AS 350 / AS 355 Blade Tie-Down Kit

View of EC 130 Blade Tie-Down Kit

Figure 1 General Layout

Transport Canada Accepted

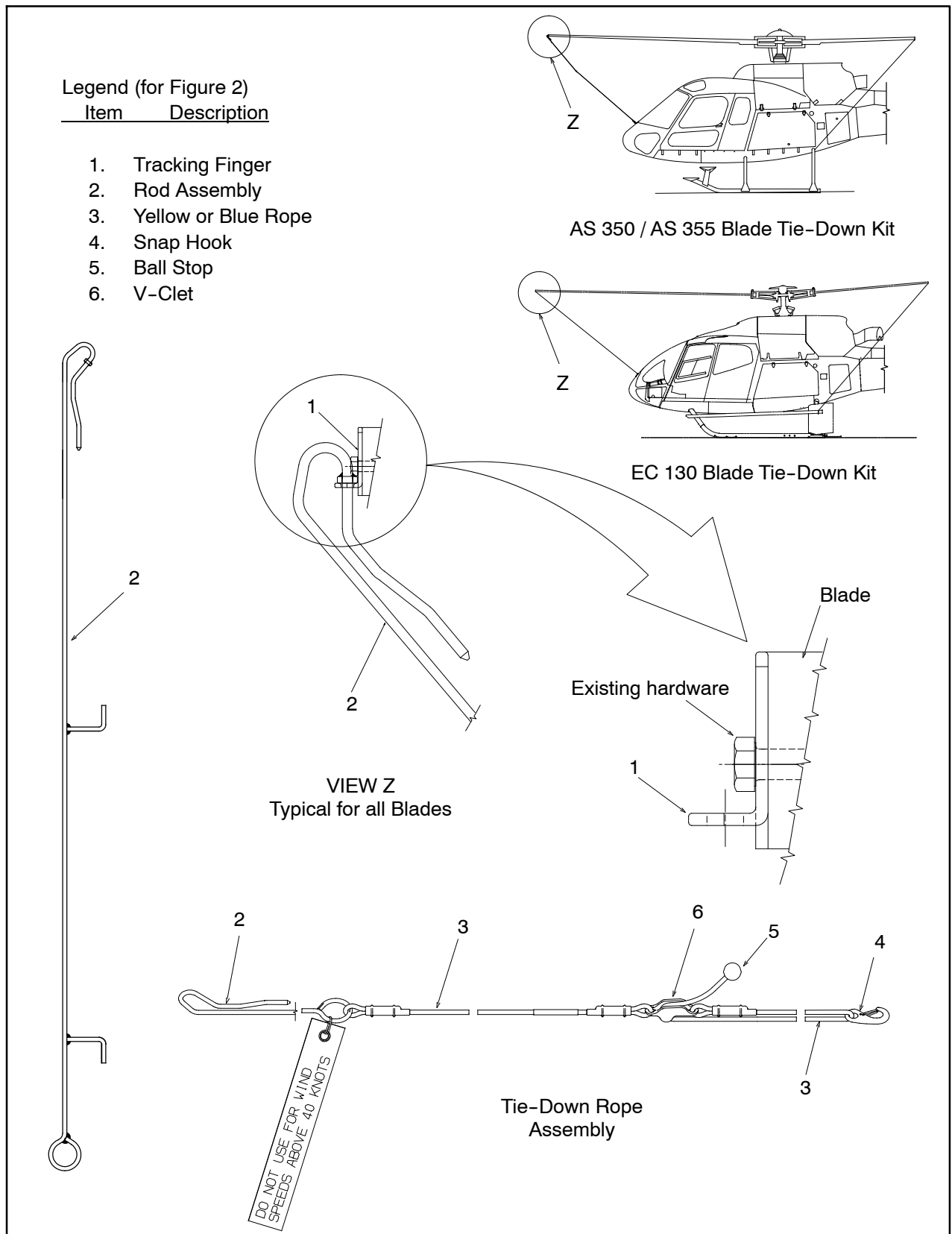

Figure 2 AS 350 / AS 355 / EC 130 Details

Transport Canada Accepted

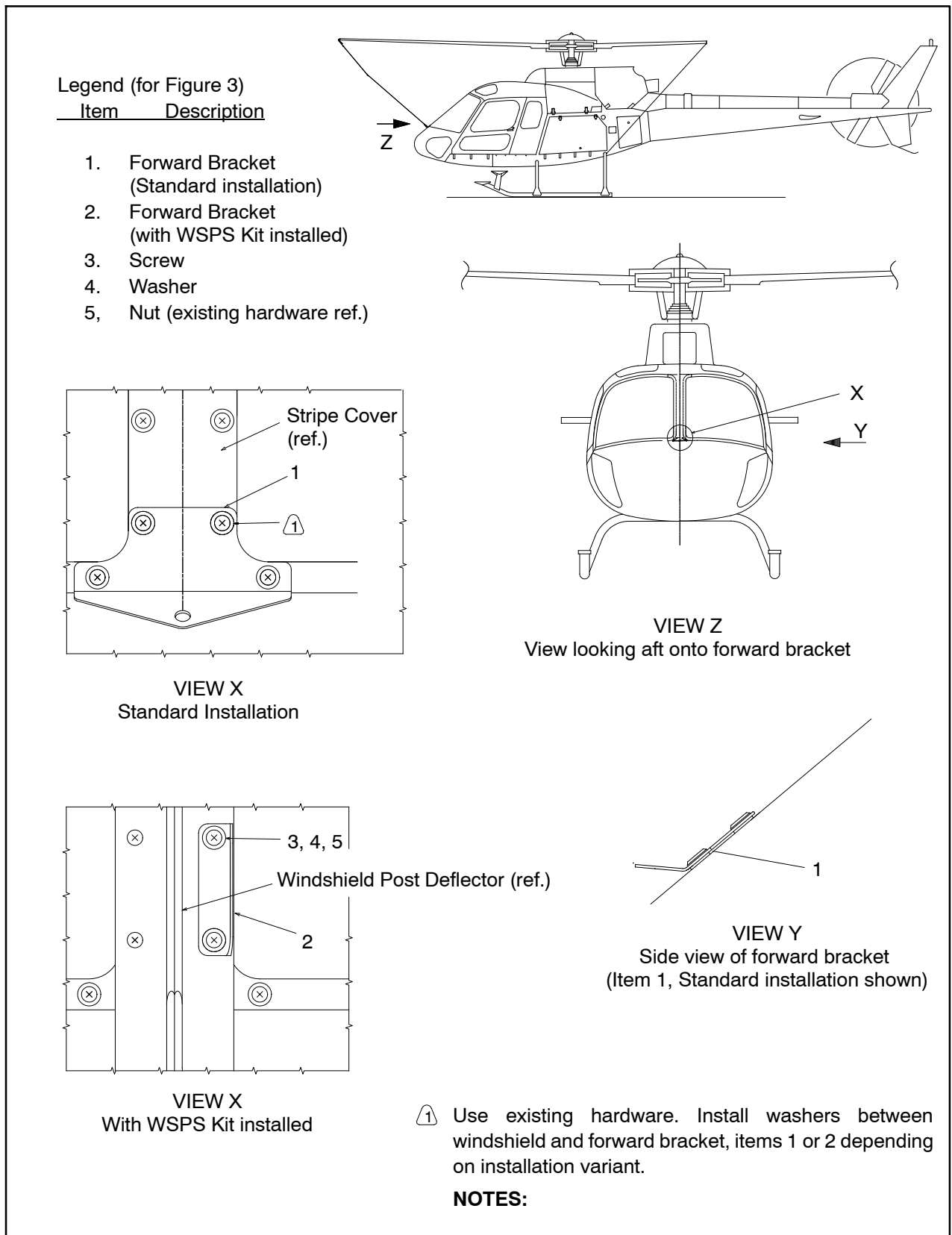

Figure 3 AS 350 / AS 355 Forward Fixed Provisions

Transport Canada Accepted



Legend (for Figure 4)
Item Description

- 1. Aft Bracket

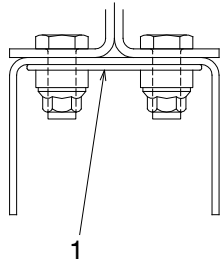
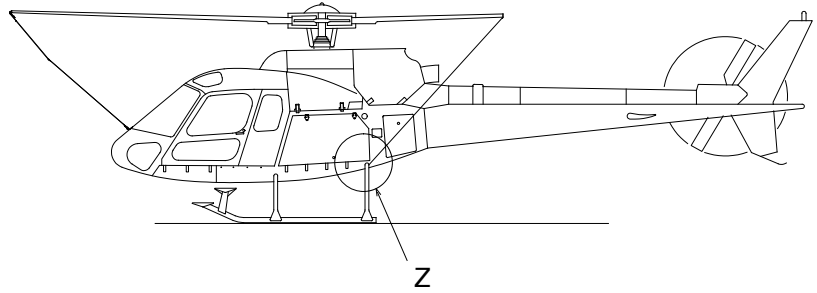

VIEW X
Standard Installation

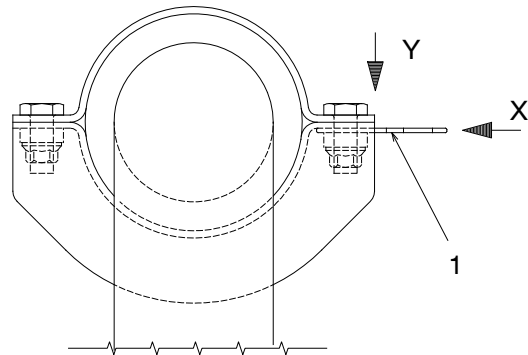

VIEW Z
View looking inboard
(LH shown, RH opposite)

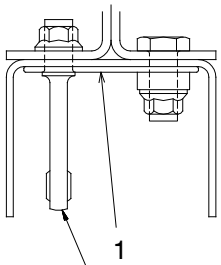

① Use existing eyebolt. Re-install in original orientation.

VIEW X
With Nightsun installed

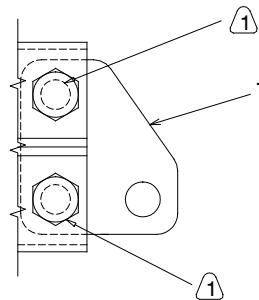

VIEW Y
View looking aft onto aft bracket
(LH shown, RH opposite)

① Use existing hardware but replace washers with aft bracket, item 1.

NOTES:

Figure 4 AS 350 / AS 355 Aft Fixed Provisions

Transport Canada Accepted

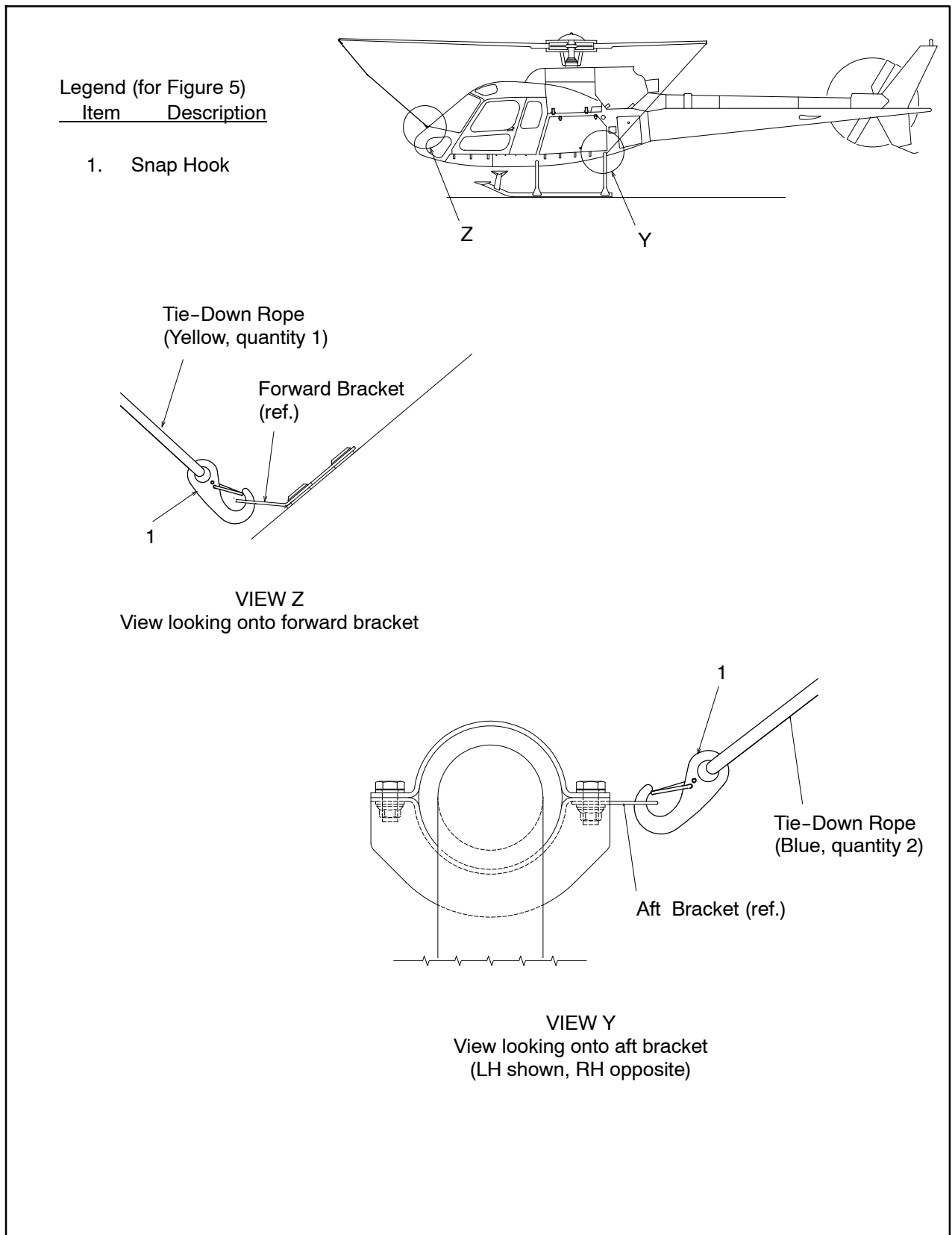

Figure 5 AS 350 / AS 355 Detachable Provisions

Transport Canada Accepted

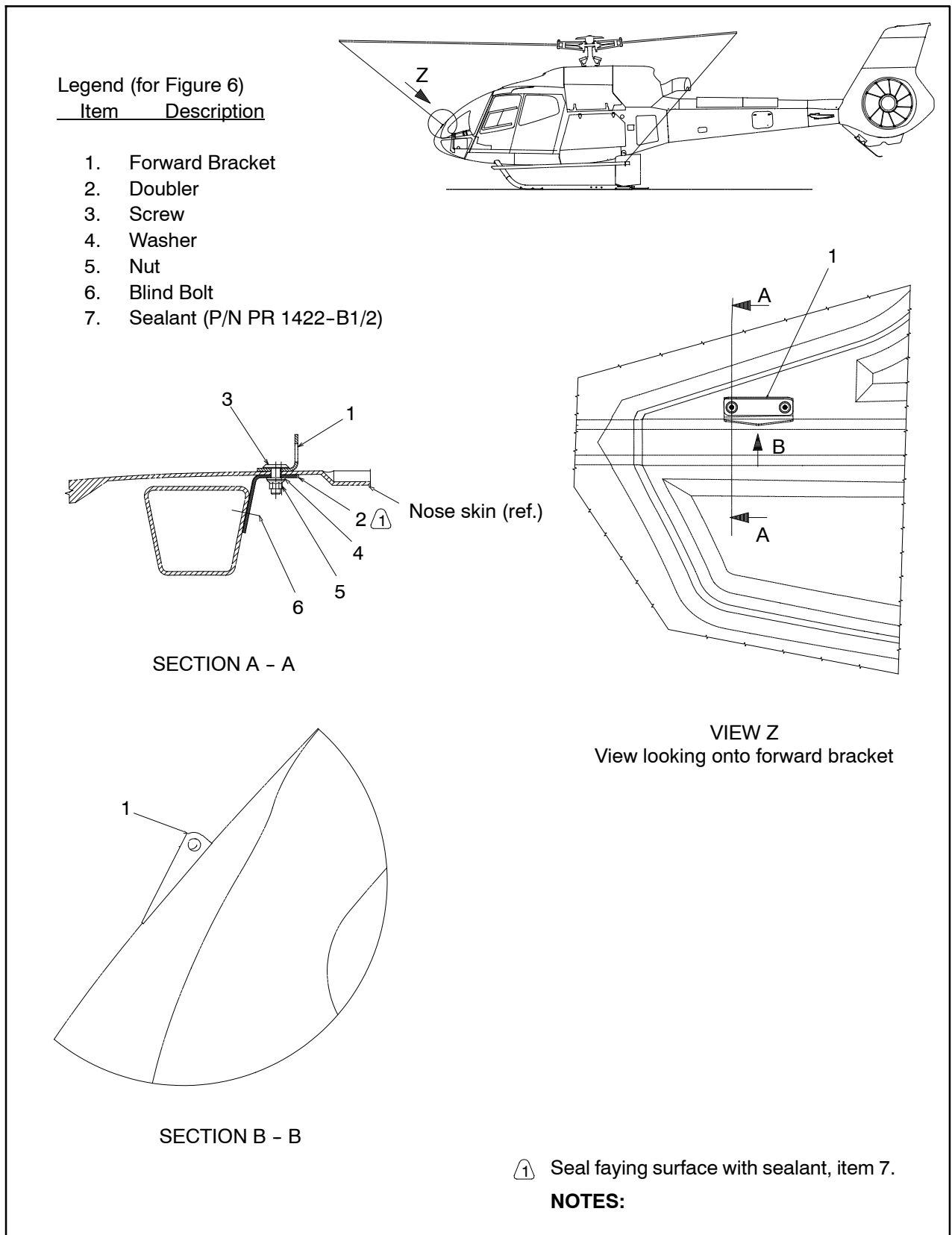

Figure 6 EC 130 Forward Fixed Provisions

Transport Canada Accepted



Legend (for Figure 7)
Item Description

1. Aft Bracket

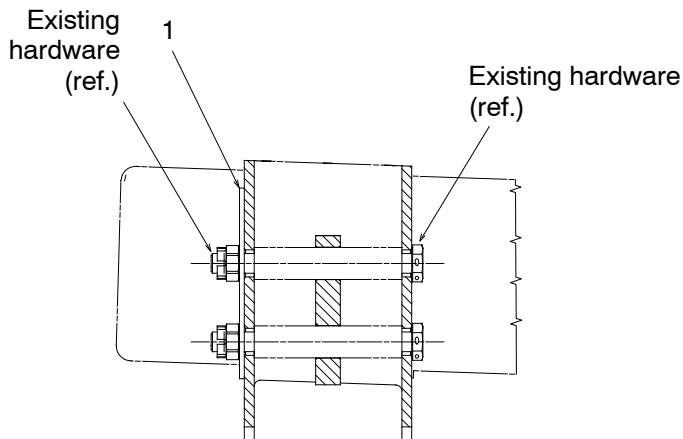
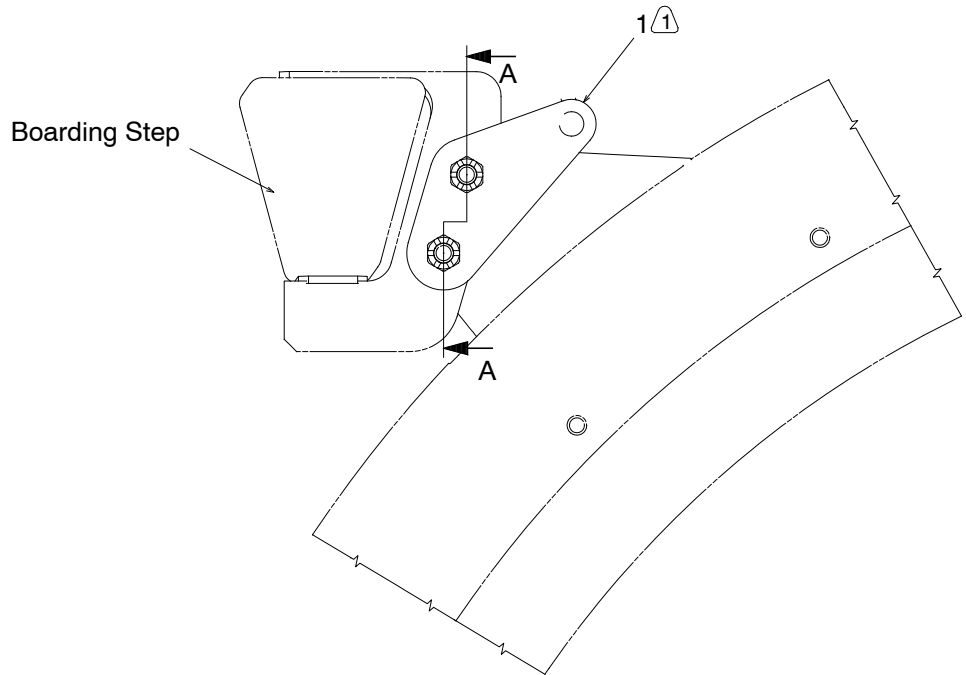
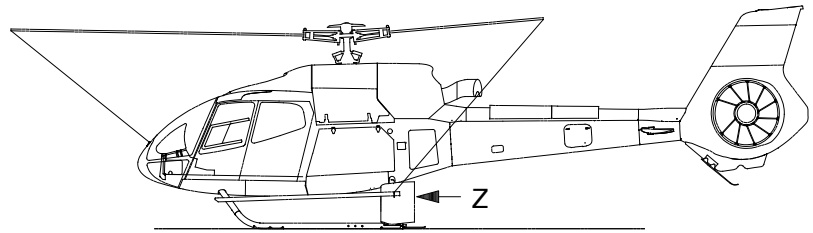

VIEW Z
View looking forward onto aft bracket
(LH shown, RH opposite)

SECTION A - A

⚠ Existing washers are replaced with aft bracket, item 1.

NOTES:

Figure 7 EC 130 Aft Fixed Provisions

Transport Canada Accepted

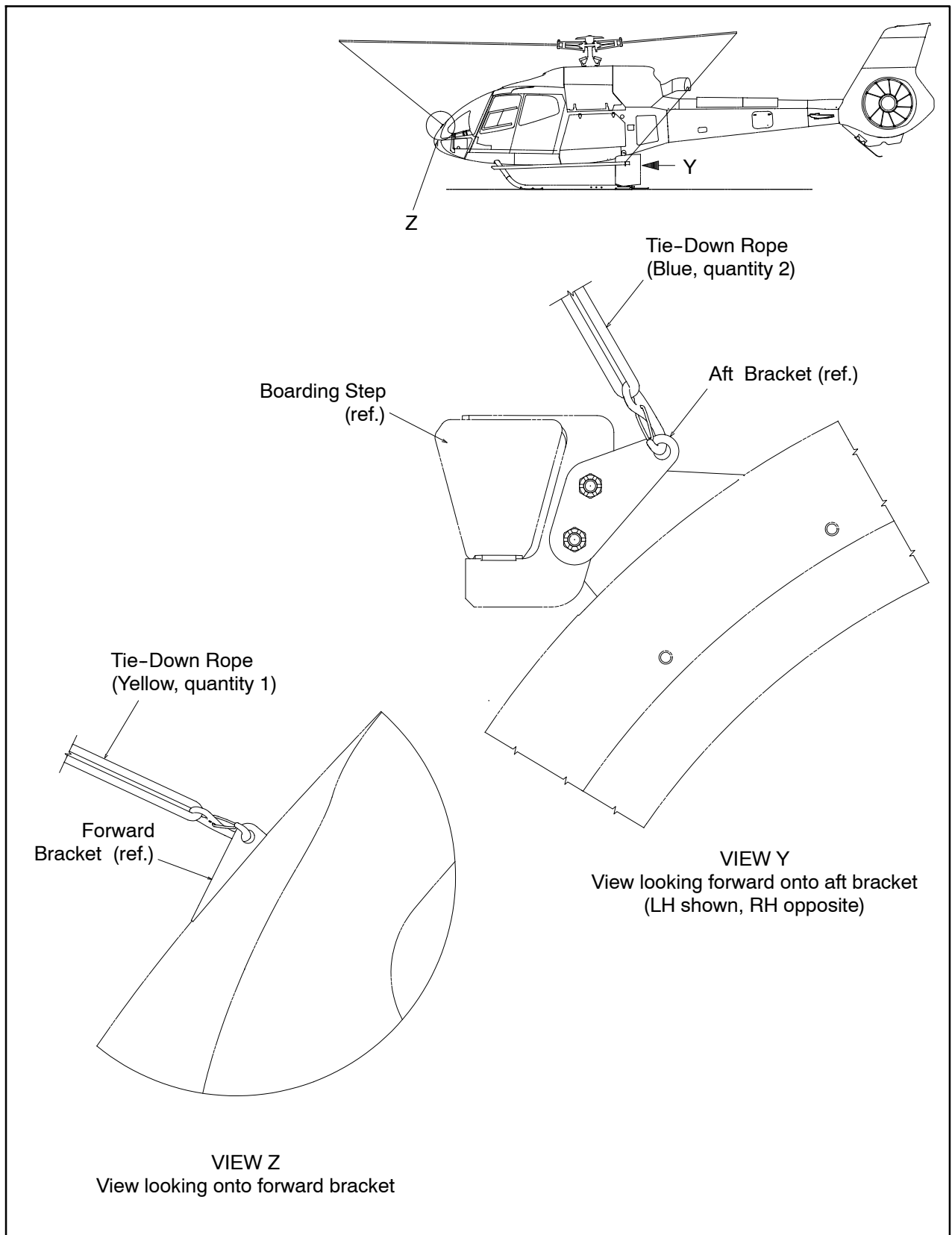

Figure 8 EC 130 Detachable Provisions

Transport Canada Accepted

C. REFERENCES

DOCUMENT	DOCUMENT TITLE
AMM (EC 130 B4)	Aircraft Maintenance Manual
IPC	Illustrated Parts Catalogue
MET (AS 350 / 355)	Maintenance Manual
MTC	Standard Practices Manual
SB 25.00.34	AS 350 Service Bulletin 25.00.34, Cable Cutter Installation

D. ABBREVIATIONS & DEFINITIONS

ABBREVIATION	DEFINITION
EC	Eurocopter (France)
ECL	Eurocopter Canada Limited
hrs	hours
LH	Left Hand
MDL	Master Drawing List
OEM	Original Equipment Manufacturer
P/N	Part Number
Qty.	Quantity
ref.	reference
RH	Right Hand
STN	Station
WSPS	Wire Strike Protection System

E. UNITS OF MEASUREMENT

ABBREVIATION / SYMBOL	UNIT OF MEASUREMENT
in	inch
kg	kilogram
lb	pound
m	meter

Transport Canada Accepted

2. **AIRWORTHINESS LIMITATIONS**

The Airworthiness Limitations section is approved by the Minister and specifies maintenance required by any applicable airworthiness or operating rule unless an alternative program has been approved by the Minister.

No airworthiness limitations associated with this installation.

Transport Canada Approved

3. CONTROL AND OPERATION

Control and operation of the aircraft remains unchanged.

If wind speeds in excess of 40 knots are anticipated, either move the aircraft into a suitable shelter or use a tie-down system appropriate for the higher wind speeds.

NOTE If wind speeds in exceeds of 40 knots are anticipated, do not use the Blade Tie-Down Kit.

The Blade Tie-Down Kit is used for ground parking only.

Follow procedure given below to secure the Blade Tie-Down Kit to the aircraft:

1. Align blade with nose of helicopter. Loosen the rope on the yellow tie-down rope assembly. Slide the rod assembly through the hole in the blade tracking fingers. Care must be taken to avoid damaging the upper surface of the blade tip. Clip rope to forward bracket. Refer to Figure 3 for the AS 350 / 355 and Figure 6 for the EC 130. Tighten rope through the v-clet. Refer to Figure 2.
2. Loosen the ropes on two remaining blue tie-down rope assemblies. Slide the rod assembly through the hole in one of the two remaining blade tracking fingers. Care must be taken to avoid damaging the upper surface of the blade tip. Clip the rope to the aft bracket. Follow same procedure for remaining blades. Refer to Figure 4 for the AS 350 / 355 and Figure 7 for the EC 130. Tighten rope through the v-clet. Refer to Figure 2.

4. INSPECTION SCHEDULE AND MAINTENANCE ACTION

NOTE Use torque per EC, MTC, Volume 2, Chapter 20.02.05.404, unless otherwise specified.

4.1. INSPECTION SCHEDULE

4.1.1. Before each installation:

ITEM	INSPECTION OR MAINTENANCE WORK	CORRECTIVE ACTION
A	<ul style="list-style-type: none"> - Visually inspect ropes, item 3, in Figure 2 for: <ul style="list-style-type: none"> a. excessive wear (visible fading, glazing, fraying, cuts, inconsistencies) 	<ul style="list-style-type: none"> a. Excessive wear is not permitted. If excessive wear is evident, contact ECL for replacement information.
B	<ul style="list-style-type: none"> - Visually inspect rod assembly, item 2, shown in Figure 2 for: <ul style="list-style-type: none"> a. cracking or deformation 	<ul style="list-style-type: none"> a. No cracking or deformation is allowed. If cracking or deformation is found, contact ECL for replacement parts.
C	<ul style="list-style-type: none"> - Visually inspect v-clets, item 6, shown in Figure 2 for: <ul style="list-style-type: none"> a. proper operation 	<ul style="list-style-type: none"> a. Ensure rope is tight in v-clet.

Table 1 Before each installation

Transport Canada Accepted

4. INSPECTION SCHEDULE AND MAINTENANCE ACTION (continued)

4.1. INSPECTION SCHEDULE

4.1.2. Every 150 flight hrs or 12 months (to coincide with the 150 hrs or 12 months helicopter inspection) whichever occurs first:

ITEM	INSPECTION OR MAINTENANCE WORK	CORRECTIVE ACTION
A	<ul style="list-style-type: none"> - Visually inspect upper surface of blade tip from STN 4650 to 4679 for: <ul style="list-style-type: none"> a. damage 	<ul style="list-style-type: none"> a. If damage is found, inspect blades as per AMM / MET, Chapter 62. Refer to Section 62.10 for AS 350/AS 355 and Section 62.11 for AS 350 B2/B3 and EC 130. Contact ECL for further information.
B	<ul style="list-style-type: none"> - Check placards and markings (refer to Section 10) for: <ul style="list-style-type: none"> a. legibility b. secure mounting 	<ul style="list-style-type: none"> a. If placard has become illegible, contact ECL for replacement parts. b. Secure or reattach placards as required.

Table 2 Inspection Schedule and Maintenance Action
Every 150 flight hrs or 12 months, whichever occurs first

4.1. INSPECTION SCHEDULE

4.1.3. Every 600 flight hrs or 24 months, whichever occurs first:

ITEM	INSPECTION OR MAINTENANCE WORK	CORRECTIVE ACTION
A	<ul style="list-style-type: none"> - Check tracking finger, item 1, shown in Figure 2, for: <ul style="list-style-type: none"> a. hole elongation and tracking finger distortion 	<ul style="list-style-type: none"> a. Contact ECL for replacement part.
B	<ul style="list-style-type: none"> - Check mounting hardware securing forward bracket (Standard Installation), item 1, shown in Figure 3 for: <ul style="list-style-type: none"> a. security 	<ul style="list-style-type: none"> a. Secure as required.
C	<ul style="list-style-type: none"> - Check mounting hardware, items 3 and 4, securing forward bracket (WSPS Kit Installation), item 2, shown in Figure 3 for: <ul style="list-style-type: none"> a. security 	<ul style="list-style-type: none"> a. Secure as required.
D	<ul style="list-style-type: none"> - Visually inspect forward brackets, items 1 and 2, shown in Figure 3 for: <ul style="list-style-type: none"> a. corrosion 	<ul style="list-style-type: none"> a. No corrosion is allowed. Contact ECL for replacement parts.

Table 3 Inspection Schedule and Maintenance Action
Every 600 flight hrs or 24 months, whichever occurs first:
(continued on following page)

Transport Canada Accepted

4. **INSPECTION SCHEDULE AND MAINTENANCE ACTION** (continued)

4.1. INSPECTION SCHEDULE

4.1.3. Every 600 flight hrs or 24 months, whichever occurs first:

ITEM	INSPECTION OR MAINTENANCE WORK	CORRECTIVE ACTION
E	- Check mounting hardware securing aft bracket, item 1, (for Standard Installation or with Nightsun installed) shown in Figure 4 for: a. security	a. Secure as required.
F	- Visually inspect aft brackets, item 1, shown in Figure 4 for: a. corrosion	a. No corrosion is allowed. Contact ECL for replacement parts.
G	- Check mounting hardware, items 3, 4, 5 and 6 securing doubler, item 2, to the forward bracket, shown in Figure 6 for: a. security	a. Secure as required.
H	- Visually inspect forward bracket, item 1 shown in Figure 6 for: a. corrosion	a. No corrosion is allowed. Contact ECL for replacement parts.
I	- Check sealant (item 7) between forward bracket (item 1), and nose skin, shown in Figure 6 for: a. deterioration	a. Clean area and reseal with sealant, item 7 (P/N PR 1422 B1/2) in accordance with EC, MTC, Chapter 20.05.01.219.
J	- Check sealant (item 7) between doubler (item 2), and nose skin, shown in Figure 6 for: a. deterioration	a. Clean area and reseal with sealant, item 7 (P/N PR 1422 B1/2) in accordance with EC, MTC, Chapter 20.05.01.219.
K	- Check mounting hardware securing aft bracket, item 1, shown in Figure 7 for: a. security	a. Secure as required.
L	- Visually inspect aft brackets, shown in Figure 7 for: a. corrosion	a. No corrosion is allowed. Contact ECL for replacement parts.

Table 3 Inspection Schedule and Maintenance Action
Every 600 flight hrs or 24 months, whichever occurs first

Transport Canada Accepted

4. INSPECTION SCHEDULE AND MAINTENANCE ACTION (continued)

4.1. INSPECTION SCHEDULE

4.1.4. Supplemental Maintenance Instructions:

Only if Blade Tie-Down was used in winds exceeding 40 knots and after Section 4.1.3 has been completed.

ITEM	INSPECTION OR MAINTENANCE WORK	CORRECTIVE ACTION
A	<ul style="list-style-type: none"> - Visually inspect ropes, item 3, shown in Figure 2 for: <ul style="list-style-type: none"> a. condition 	<ul style="list-style-type: none"> a. If rope is damaged, contact ECL for replacement part.
B	<ul style="list-style-type: none"> - Visually inspect snap hook, item 4, ball stop, item 5 and v-clet, item 6, shown in Figure 2 for: <ul style="list-style-type: none"> a. condition 	<ul style="list-style-type: none"> a. If parts are damaged, contact ECL for replacement parts.
C	<ul style="list-style-type: none"> - Visually inspect rod, item 2, shown in Figure 2 for: <ul style="list-style-type: none"> a. Damage 	<ul style="list-style-type: none"> a. If rod is damaged, contact ECL for replacement part.
D	<ul style="list-style-type: none"> - Visually inspect tracking finger (item 1) in Figure 2 for: <ul style="list-style-type: none"> a. Loose or damaged hardware b. distortion 	<ul style="list-style-type: none"> a. Inspect blade for cause as per AMM / MET and contact ECL for further information. b. No distortion is allowed. If distortion is found, contact ECL for replacement parts.
E	<ul style="list-style-type: none"> - Visually inspect forward bracket, items 1 or 2 shown in Figure 3 and aft bracket, item 1, shown in Figure 4 for: <ul style="list-style-type: none"> a. cracking or deformation 	<ul style="list-style-type: none"> a. No cracking or deformation is allowed. If cracking or deformation is found, contact ECL for replacement parts.
F	<ul style="list-style-type: none"> - Visually inspect aircraft structure around forward brackets, items 1 or 2, shown in Figure 3 and aft bracket, item 1, shown in Figure 4 for: <ul style="list-style-type: none"> a. damage or deformation 	<ul style="list-style-type: none"> a. If damage or deformation exists repair in accordance with Aircraft / Maintenance Manual.

Table 4 Inspection Schedule and Maintenance Action
Supplemental Maintenance Instructions
(continued on following page)

Transport Canada Accepted

4. INSPECTION SCHEDULE AND MAINTENANCE ACTION (continued)

4.1. INSPECTION SCHEDULE

4.1.4. Supplemental Maintenance Instructions:

ITEM	INSPECTION OR MAINTENANCE WORK	CORRECTIVE ACTION
G	<ul style="list-style-type: none"> - Visually inspect forward bracket, item 1 and doubler, item 2, shown in Figure 6 for: a. cracking or deformation 	<ul style="list-style-type: none"> a. No cracking or deformation is allowed. If cracking or deformation is found, contact ECL for replacement parts.
H	<ul style="list-style-type: none"> - Visually inspect aircraft structure around forward bracket, item 1 and doubler, item 2, shown in Figure 6 for: a. damage or deformation 	<ul style="list-style-type: none"> a. If damage or deformation exists repair in accordance with Aircraft / Maintenance Manual.
I	<ul style="list-style-type: none"> - Visually inspect aft bracket, item 1, shown in Figure 7 for: a. cracking or deformation 	<ul style="list-style-type: none"> a. No cracking or deformation is allowed. If cracking or deformation is found, contact ECL for replacement parts.

Table 4 Inspection Schedule and Maintenance Action
Supplemental Maintenance Instructions

5. REPLACEMENT COMPONENTS AND REPAIR / OVERHAUL INFORMATION

Contact ECL for replacement parts. No overhaul information required for this installation.

6. TROUBLESHOOTING

There are no unique characteristics which require troubleshooting techniques.

7. SPECIAL TOOLING

No special test equipment or tools are required. Standard tools are adequate.

Transport Canada Accepted

8. REMOVAL AND REPLACEMENT

A. REMOVAL

NOTE Use torque per EC, MTC, Volume 2, Chapter 20.02.05.404, unless otherwise specified.

1) DETACHABLES

- a) Release the tension on each tie-down strap and release the snap hooks (3 places) secured to each fixed provision located on the lower portion of the tie-down straps.
- b) Remove the rod assemblies (3 places) from each blade tracking finger.

FOR AS 350 / AS 355

2) FORWARD BRACKET (Standard Installation) (Refer to Figure 3)

- a) Remove existing OEM screws (4 places), washers (8 places) and nuts (4 places) from the windshield strip cover and remove forward bracket (1) from aircraft.
- b) Reinstall OEM hardware into windshield strip cover.

3) FORWARD BRACKET (with WSPS Kit Installed) (Refer to Figure 3)

- a) Remove screws (3) (2 places), washers (4) (2 places) and OEM nuts (2 places) from the windshield post deflector and remove forward bracket (2) from aircraft. Retain hardware for reinstallation.
- b) Secure windshield post deflector using installation hardware specified in:
 - EC AS 350 Service Bulletin, Cable Cutter Installation P/N SB 25.00.34.
 - EC AS 355 Service Bulletin, Cable Cutter Installation P/N SB 25.00.24 (SB no longer applicable as of September 1, 2011).

4) AFT BRACKET (Refer to Figure 4)

- a) Remove existing hardware from the aft side of both rear half-clamps and remove the aft bracket (1) (2 places).
- b) Secure both rear half-clamp using existing hardware. Replace aft bracket (1) (2 places) with washer (2 places). Refer to IPC, Chapter 32.10.10.000 for washer part number.

FOR EC 130

5) FORWARD BRACKET (Refer to Figure 6)

- a) Remove screws (3) (2 places), washers (4) (2 places) and nuts (5) (2 places) securing the forward bracket (1) to the aircraft. Remove the forward bracket (1).
- b) Remove the blind bolts (6) (3 places) securing the doubler (2) to the canopy post. Remove the doubler (2).

6) AFT BRACKET (Refer to Figure 7)

- a) Leaving the screws in place, remove the existing OEM nuts securing the aft section of each boarding step and remove each aft bracket (1) (2 places).
- b) Secure both aft sections using washers (2 places) and previously removed OEM nuts. Refer to IPC, Chapter 32-11-10-05 for washer part number.
- c) Torque nuts in accordance with AMM, Chapter 32-11-00, 4-2.

Transport Canada Accepted

8. **REMOVAL AND REPLACEMENT** (continued)

B. **REPLACEMENT**

NOTE Use torque per EC, MTC, Volume 2, Chapter 20.02.05.404, unless otherwise specified.

NOTE If wind speeds in exceeds of 40 knots are anticipated, do not use the Blade Tie-Down Kit.

WARNING **ENSURE THAT THE TIE-DOWN ROPES AND RODS ARE
REMOVED PRIOR TO NEXT FLIGHT**

1) **DETACHABLES**

- a) Align main rotor into position for installation of blade tie-down kit.
- b) Insert the rod assemblies (3 places) attached to the tie-down straps into the holes of the blade tracking fingers.
- c) Insert the snap hooks (3 places) of the lower ends of the tie-down ropes into the fixed provisions located on the forward bracket of the windshield and on the aft bracket of the LH and RH cross tube mounts.
- d) Tighten the rope to the desired tension.

FOR AS 350 / AS 355

2) **FORWARD BRACKET** (Standard Installation) (Refer to Figure 3)

- a) Remove existing OEM screws (4 places), washers (8 places) and nuts (4 places) from the windshield strip cover.
- b) Reposition forward bracket (1) on aircraft and secure using existing OEM hardware.

3) **FORWARD BRACKET** (with WSPS Installed) (Refer to Figure 3)

- a) Remove hardware from the windshield strip cover from installation location.
- b) Reposition forward bracket (2) on aircraft and secure using screws (3) (2 places), washers (4) (2 places) and OEM nuts (2 places).

4) **AFT BRACKET** (Refer to Figure 4)

- a) Remove existing OEM hardware from the aft side of the rear half-clamp and remove the aft bracket.
- b) Replace washers with aft bracket (1) and secure using OEM hardware.

FOR EC 130

5) **FORWARD BRACKET** (Refer to Figure 6)

- a) Apply sealant (7) and wet install doubler (2) and secure to the canopy post using blind bolts (6) (3 places).
- b) Position forward bracket (1) on the nose skin and secure using screws (3) (2 places), washers (4) (2 places) and nuts (5) (2 places).

6) **AFT BRACKET** (Refer to Figure 7)

- a) Leaving the screws in place, remove the existing OEM nuts securing the aft section of each boarding step and remove the washer (1) (2 places).
- b) Replace washers with aft brackets (2 places) and previously removed OEM nuts.
- c) Torque nuts in accordance with AMM, Chapter 32-11-00, 4-2.

Transport Canada Accepted

9. WEIGHT AND BALANCE DATA

Weight and Balance Data for the AS 350 and AS 355 Standard Installation.

A. Removed Items

DESCRIPTION	WEIGHT		ARM		MOMENT	
	kg	lbs	m	in	kg m	lb in
Not applicable	0.00	0.0	0.00	0.0	0.00	0.0
Total	0.00	0.0	0.00	0.0	0.00	0.0

B. Added Items

DESCRIPTION	WEIGHT		ARM		MOMENT	
	kg	lbs	m	in	kg m	lb in
Forward Bracket (Standard)	0.08	0.2	0.43	16.9	0.03	3.4
Aft Brackets	0.05	0.1	4.13	162.6	0.21	16.3
Total	0.13	0.3	1.85	65.5	0.24	19.6

Weight and Balance Data for the AS 350 and AS 355 with Wire Strike Protection System (WSPS) Kit installed.

A. Removed Items

DESCRIPTION	WEIGHT		ARM		MOMENT	
	kg	lbs	m	in	kg m	lb in
Not applicable	0.00	0.0	0.00	0.0	0.00	0.0
Total	0.00	0.0	0.00	0.0	0.00	0.0

B. Added Items

DESCRIPTION	WEIGHT		ARM		MOMENT	
	kg	lbs	m	in	kg m	lb in
Forward Bracket (WSPS)	0.03	0.1	0.43	16.9	0.01	1.7
Aft Brackets	0.05	0.1	4.13	162.6	0.21	16.3
Total	0.08	0.2	2.74	89.8	0.22	18.0

Transport Canada Accepted

9. **WEIGHT AND BALANCE DATA** (continued)

Weight and Balance Data for the EC 130.

A. <u>Removed Items</u>						
DESCRIPTION	WEIGHT		ARM		MOMENT	
	kg	lbs	m	in	kg m	lb in
Not applicable	0.00	0.0	0.00	0.0	0.00	0.0
Total	0.00	0.0	0.00	0.0	0.00	0.0

B. <u>Added Items</u>						
DESCRIPTION	WEIGHT		ARM		MOMENT	
	kg	lbs	m	in	kg m	lb in
Forward Bracket	0.03	0.1	0.24	9.4	0.01	0.9
Doubler	0.07	0.1	0.24	9.4	0.02	0.9
Aft Brackets	0.09	0.2	4.13	162.6	0.19	32.5
Total	0.19	0.4	2.10	86.0	0.40	34.4

Transport Canada Accepted

10. **PLACARDS AND MARKINGS**

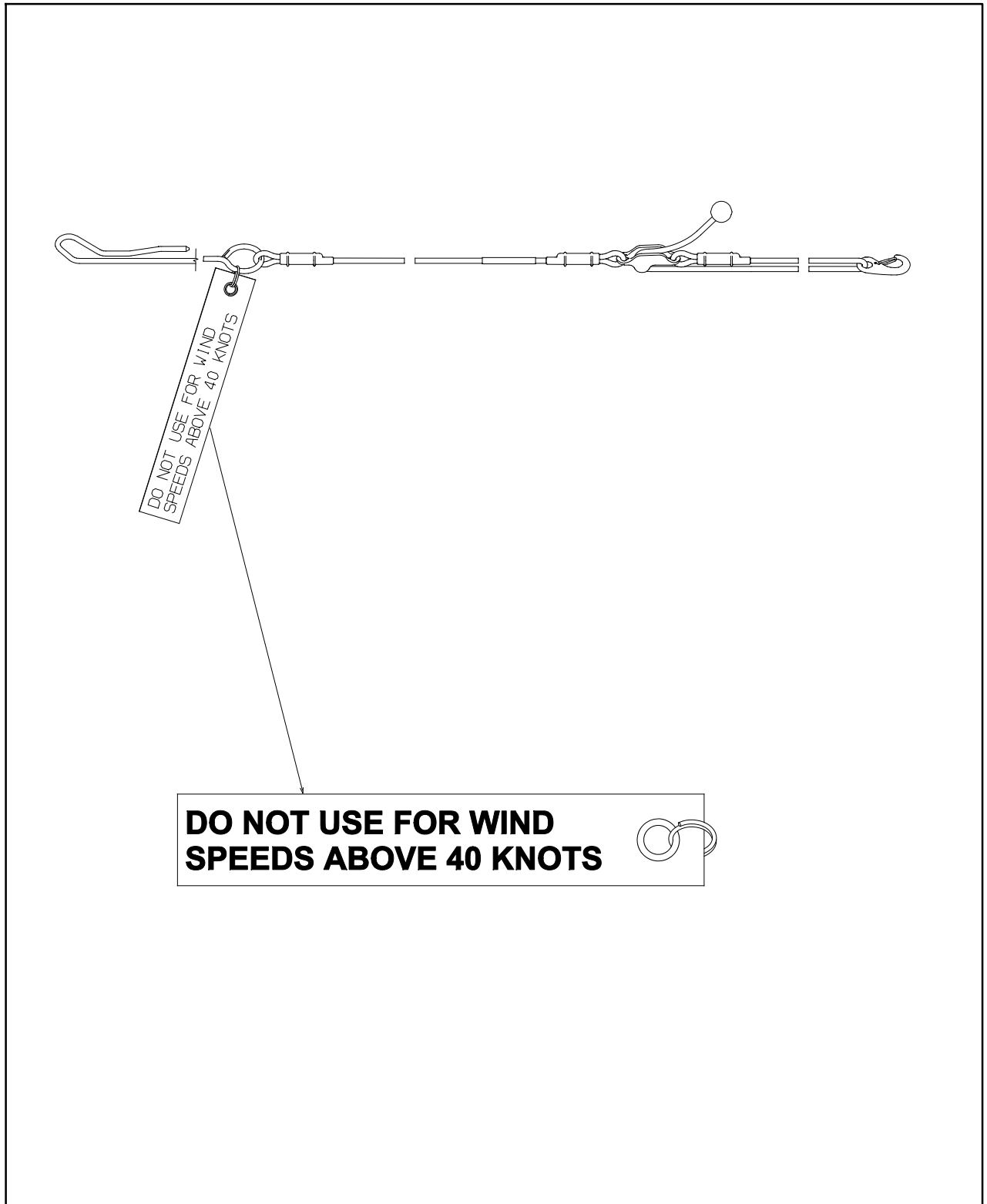

Figure 9 Typical location of Warning Flag on Tie-Down Rope Assembly

Transport Canada - Accepted