



SUBJECT:

Required maintenance for the Two Place Forward Passenger Seat (P/N 350-200624).

APPLICABILITY :

These Instructions for Continued Airworthiness are applicable to aircraft with the subject modification embodied.

THE INFORMATION CONTAINED IN THIS DOCUMENT SHALL BE TREATED AS THE PROPERTY OF EUROCOPTER CANADA LIMITED (ECL). THE RECIPIENT OF THIS DOCUMENT SHALL NOT DISCLOSE ANY INFORMATION CONTAINED HEREIN TO THIRD PARTIES WITHOUT THE WRITTEN PERMISSION OF ECL, AND SHALL NOT USE OR REPRODUCE THIS DOCUMENT IN WHOLE OR IN PART FOR ANY PURPOSE OTHER THAN ITS ORIGINALLY INTENDED PURPOSE, OR TO EVALUATE ITS CONTENTS.

	NAME AND SIGNATURE	DATE	COMPANY DEPARTMENT
PREPARED BY:	D. Kerr <i>D. Kerr</i>	12 Dec., 2013	ECL ENGINEERING
PREPARED BY:			
CHECKED BY:	C. Timmins <i>C. Timmins</i>	12 th Dec, 2013	ECL ENGINEERING
CHECKED BY:	M. Merritt <i>M. Merritt</i>	2013-12-13	ECL QUALITY ASSURANCE
APP'D / ACCEPTED (Civil A/W Authority)	(As per ICA Compliance Check Sheet) <i>C. Timmins</i>	17 th Dec, 2013	TCCA
RELEASED BY:	P. Sharpe <i>P. Sharpe</i>	18 Dec 2013	ECL ENGINEERING



CONTENTS

SECTION	TITLE	PAGE
1	GENERAL	4
2	AIRWORTHINESS LIMITATIONS	16
3	CONTROL AND OPERATION	17
4	INSPECTION SCHEDULE AND MAINTENANCE ACTION	17
5	REPLACEMENT COMPONENTS AND REPAIR / OVERHAUL INFORMATION	18
6	TROUBLESHOOTING	19
7	SPECIAL TOOLING	20
8	REMOVAL AND REPLACEMENT	20
9	WEIGHT AND BALANCE	24
10	PLACARDS AND MARKINGS	25

FIGURES

FIGURE	TITLE	PAGE
1	General Layout	5
2	Two Place Forward Passenger Seat - 01 Variant	6
3	Two Place Forward Passenger Seat - 02 & - 03 Variant	7
4	Seat Belt Attachment	8
5	Seat Attachment Locations	9
6	Seat Rail Installation	10
7	Cabin Floor Modifications	11
8	Cabin Floor Modifications Continued	12
9	Utility Power Plug Relocation	13
10	Data Plate relocation	14
11	Wiring Diagram, Utility Power Plug Relocation	19
12	Identification label location in nosebay (POST AMS 07-3273 & POST AMS 07-4280)	25
13	Typical placard located on Instrument Panel	26

TABLES

TABLE	TITLE	PAGE
1	Inspection Schedule and Maintenance Action Every 150 FH or 12 M (Margins: 15 FH or 36 D)	17

Transport Canada Accepted



1. GENERAL

- A. The Two Place Forward Passenger Seat is a composite-structure double seat that is secured to fixed seat rails on the cabin floor. When the two-place seat is mounted in lieu of the right hand pilot's seat the aircraft can carry seven persons. To provide additional leg room for the center passenger, the complete center console structure is removed as part of the Left-Side Pilot Configuration. Refer to Figure 1 for General Layout.

A prerequisite to this installation is the Left Side Pilot Configuration which must be installed in accordance with TCCA (Transport Canada Civil Aviation) STC (Supplemental Type Certificate) SH96-32.

The utility power plug is relocated from the back face of the control quadrant to the left side of the center console. The data plate is relocated from the right hand cabin floor to the right side of the fuselage near the maintenance step.

The Two Place Forward Passenger Seat is available in the following variants:

Installation Drawing number	Variant	Description
350-200704-01	- 01 variant (350-200704-01) Refer to Figure 2	- 3 pt. seat belts
350-200704-02	- 02 variant (350-200704-02) Refer to Figure 3	- 4 pt. seat belts - without adjusters
350-200704-03	- 03 variant (350-200704-03) Refer to Figure 3	- 4 pt. seat belts - with adjusters

The Two Place Forward Passenger Seat consists of the following main components:

Detachable Provisions

- Double Seat Assembly

Fixed Provisions

- Seat Rails
- Intercostal
- Clips

The Two Place Forward Passenger Seat is installed in accordance with STC SH96-39.

- B. These Instructions for Continued Airworthiness are applicable to aircraft with the subject modification embodied.

Transport Canada Accepted

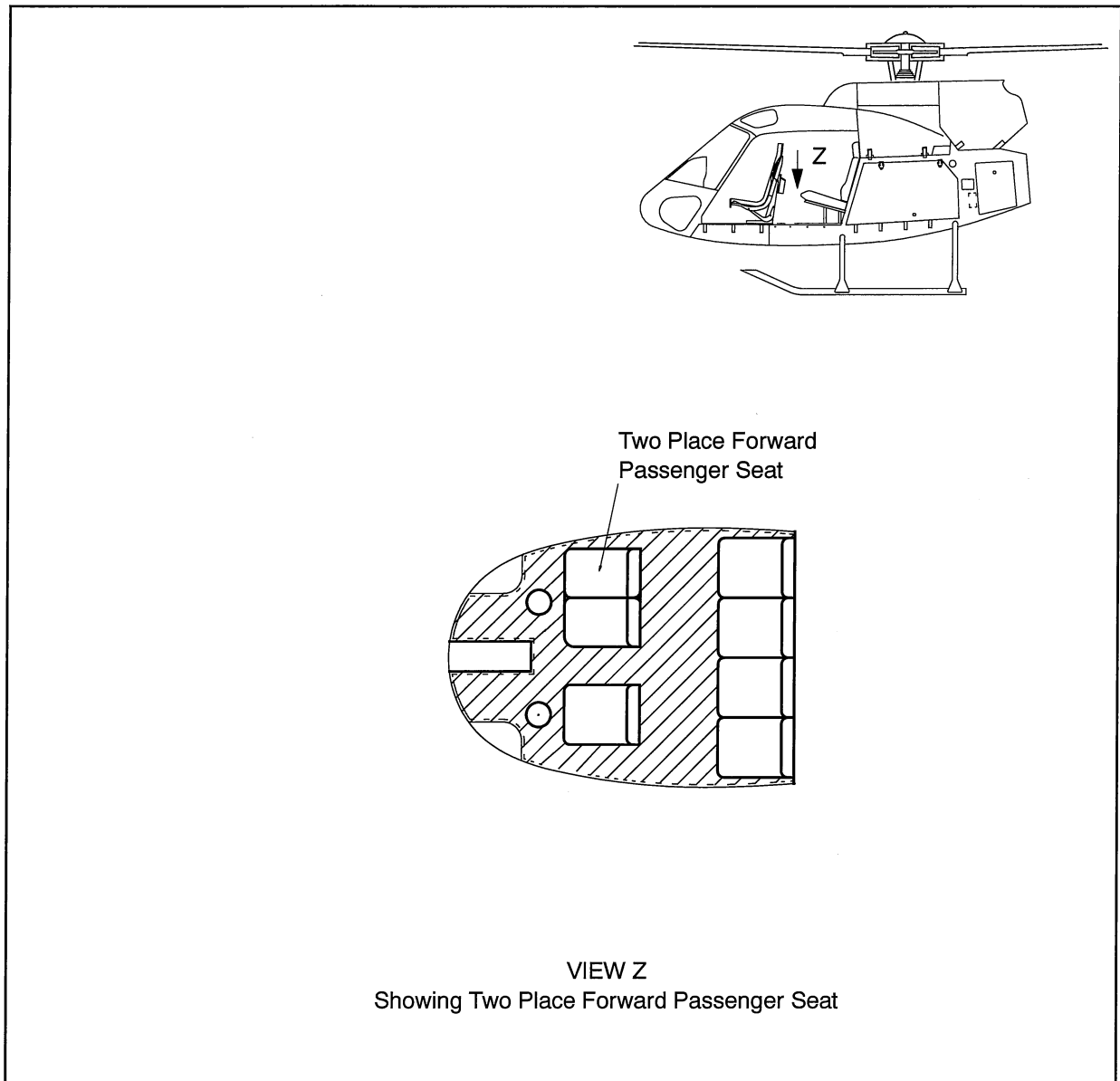

Figure 1 General Layout

Transport Canada Accepted

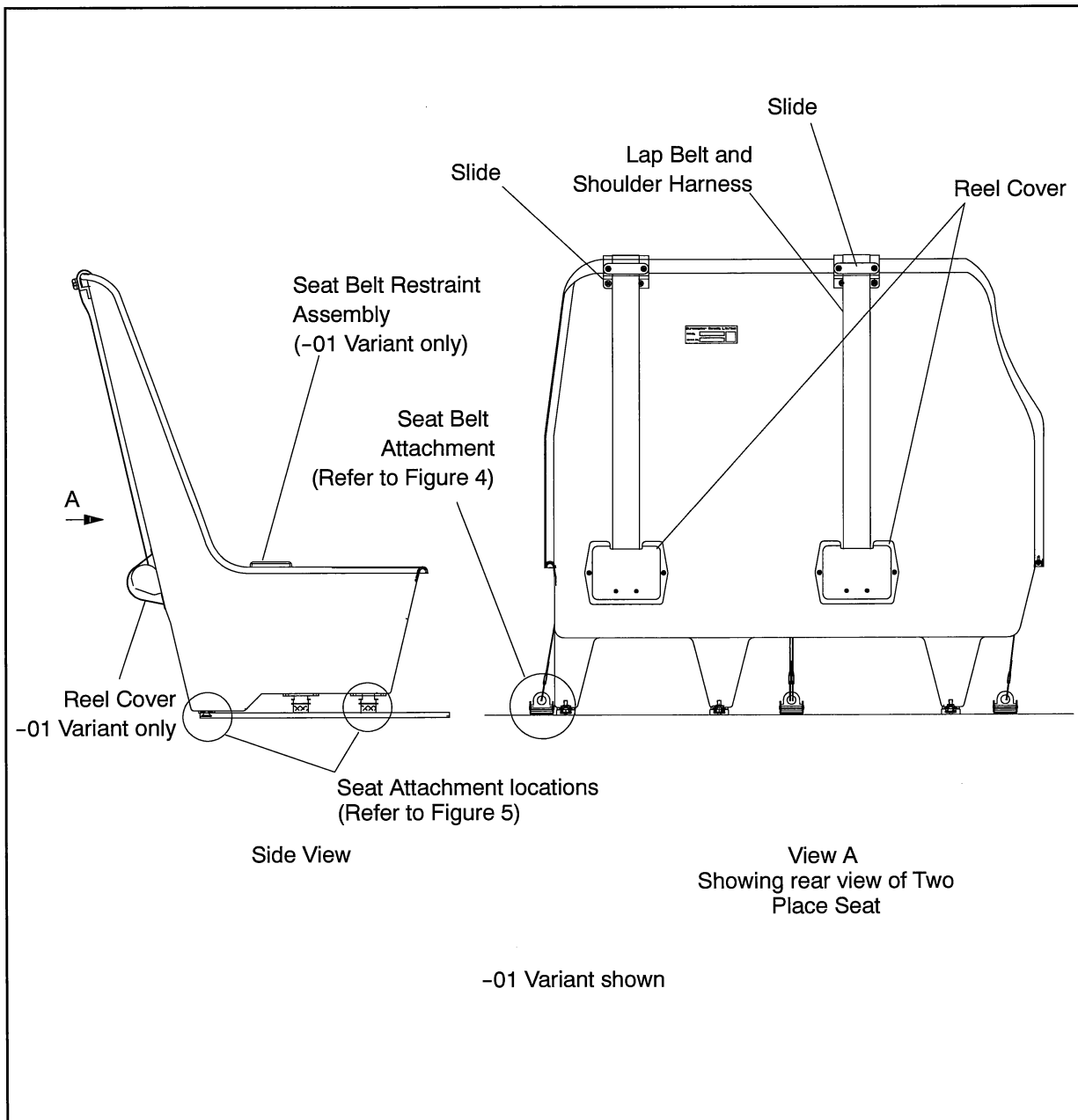

Figure 2 Two Place Forward Passenger Seat - 01 Variant

Transport Canada Accepted

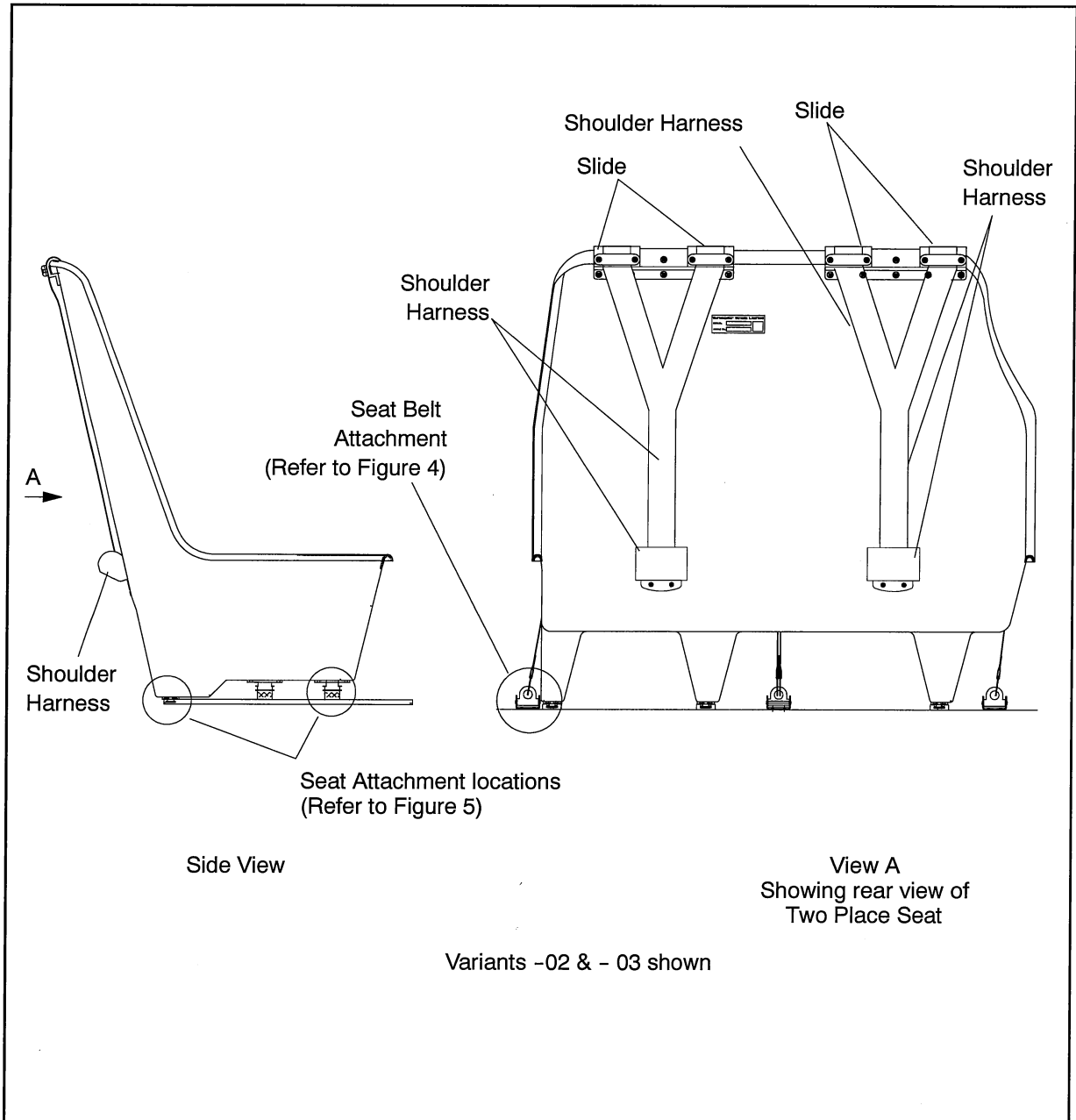

Figure 3 Two Place Forward Passenger Seat - 02 & -03 Variants

Transport Canada Accepted



Legend (for Figure 4)

Item Description

1. Ring
2. Seat Belt Assembly Bracket
3. Cotter Pin
4. Pin
5. Washer
6. Screw
7. Profile Washer

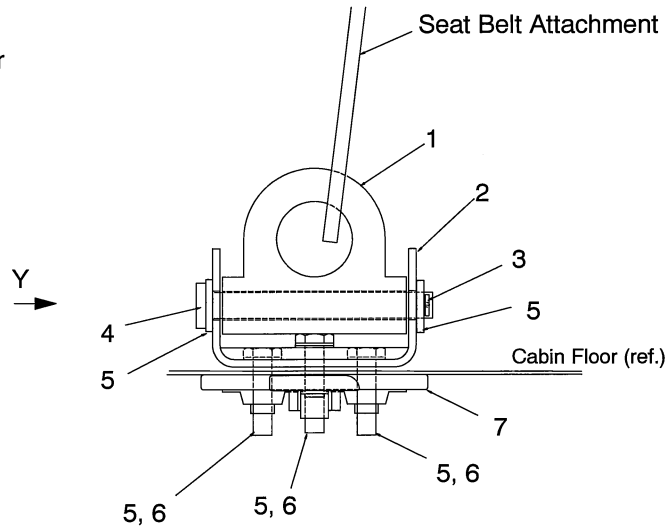
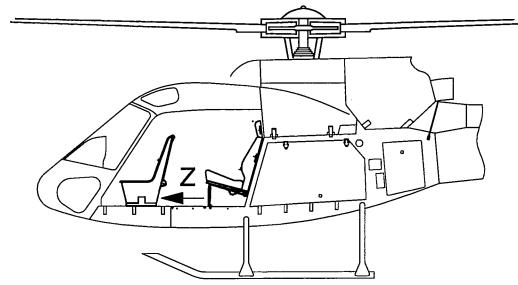

VIEW Z

Looking forward at Seat Belt Attachment

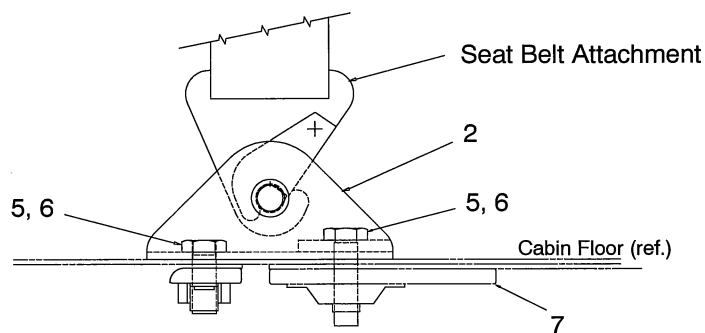

VIEW Y

Looking inboard at Seat Belt Attachment

Figure 4 Seat Belt Attachment

Transport Canada Accepted

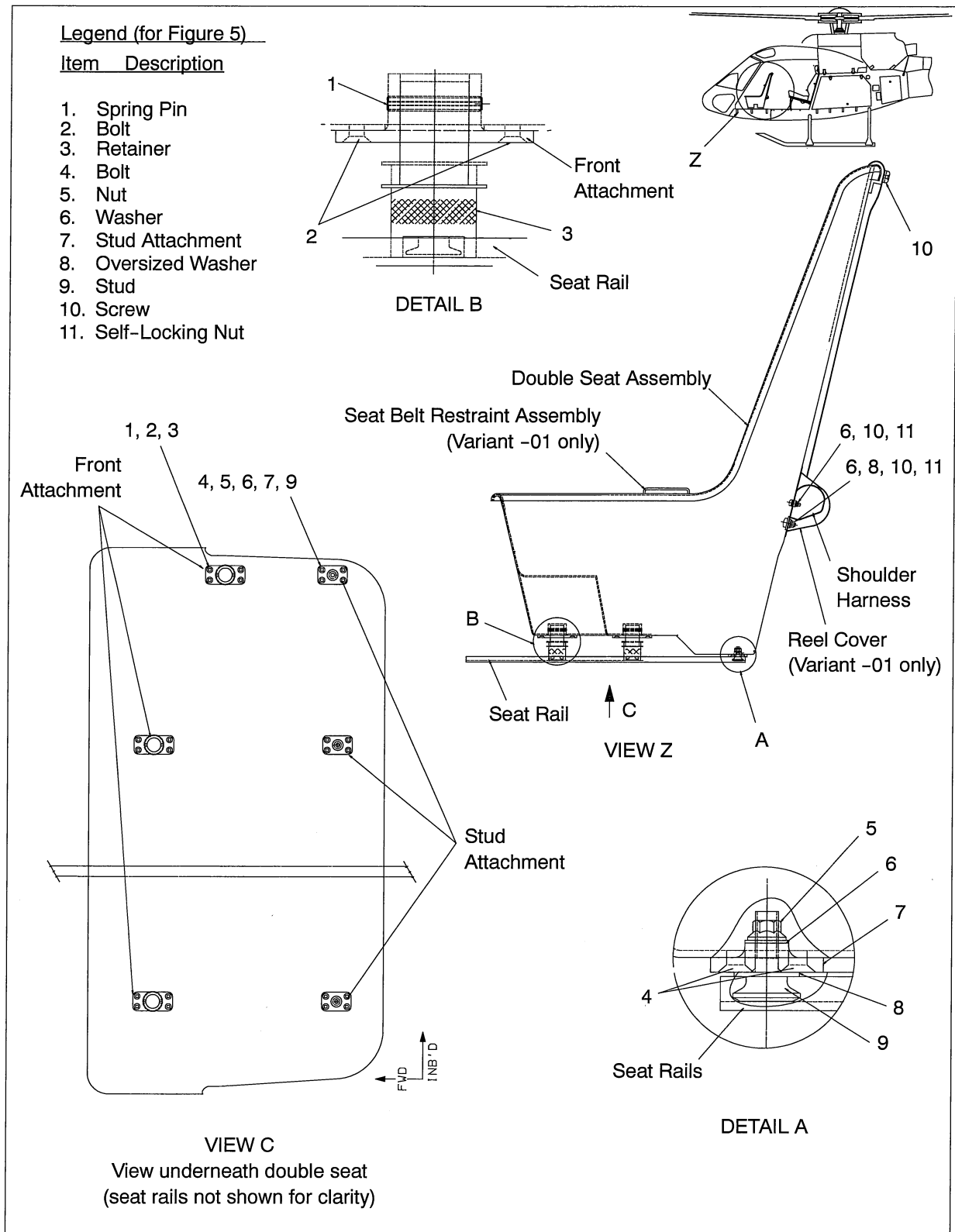

Figure 5 Seat Attachment Locations

Transport Canada Accepted

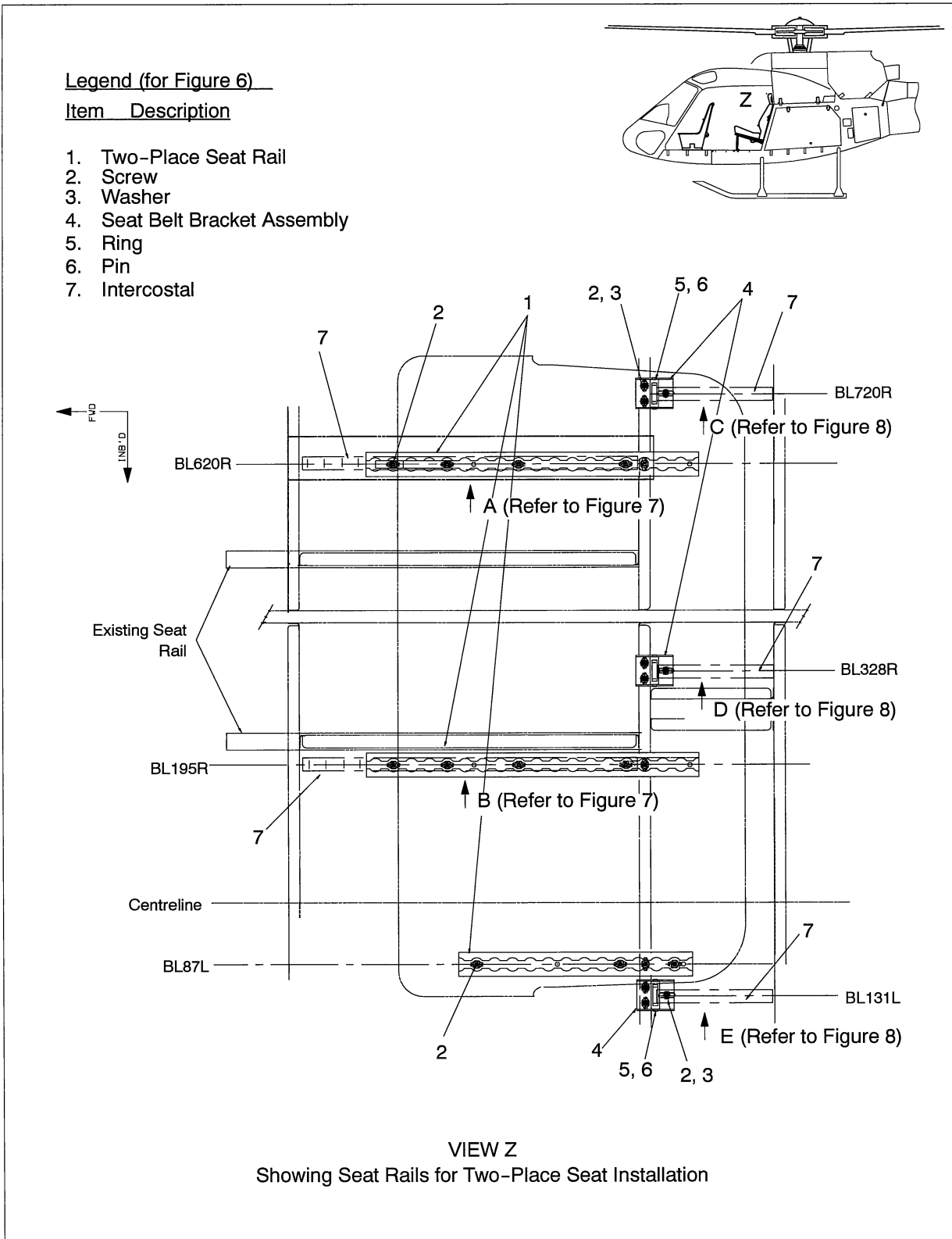

Figure 6 Seat Rail Installation

Transport Canada Accepted



Legend (for Figure 7)

Item Description

- | | |
|------------------------------|-----------------------------|
| 1. Two-Place Seat Rail | 7. Anchor Nuts |
| 2. Rivets (P/N MS20470AD4-4) | 8. Intercostal |
| 3. Rivets (P/N MS20426AD4-4) | 9. Profile Washer |
| 4. Rivets (P/N CCR2634553-3) | 10. Attachment Plate (ref.) |
| 5. Rivets (P/N MS20470AD5-5) | |
| 6. Clip | |

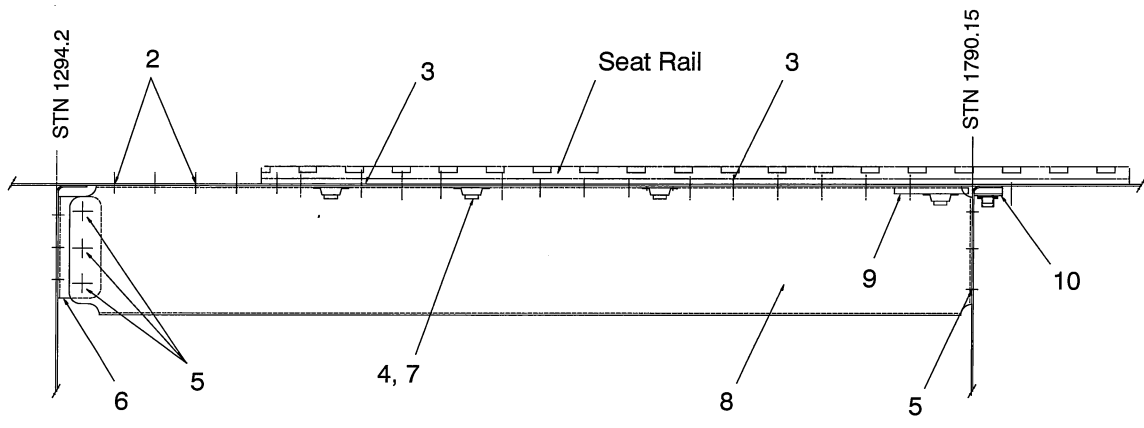

VIEW A
Showing the Cabin Floor Modifications

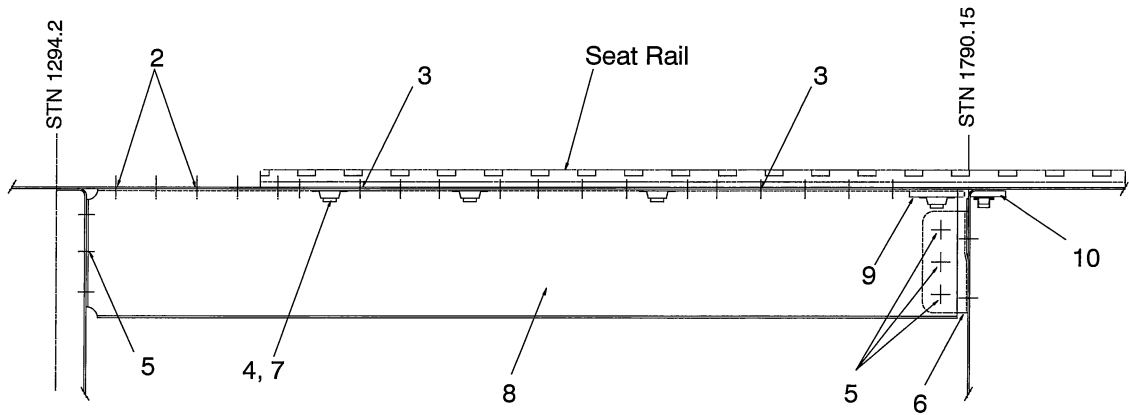

VIEW B
Showing the Cabin Floor Modifications

Figure 7 Cabin Floor Modifications

Transport Canada Accepted



Legend (for Figure 8)

Item Description

1. Seat Belt Bracket
2. Rivets (P/N MS20470AD4-4)
3. Rivets (P/N MS20470AD5-5)
4. Rivets (P/N MS20470AD5-8)
5. Clip
6. Patch Plate (ref.)
7. Anchor Nuts
8. Intercostal
9. Profile Washer

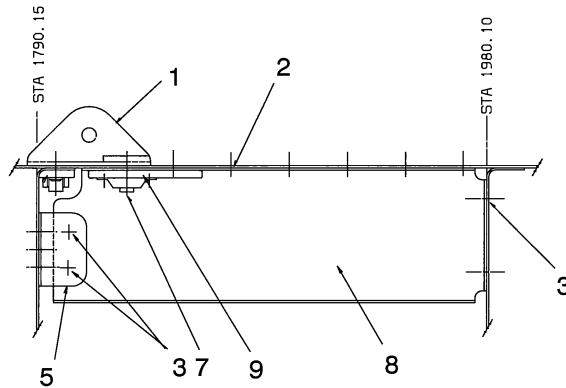

VIEW C
Showing the Cabin Floor Modifications

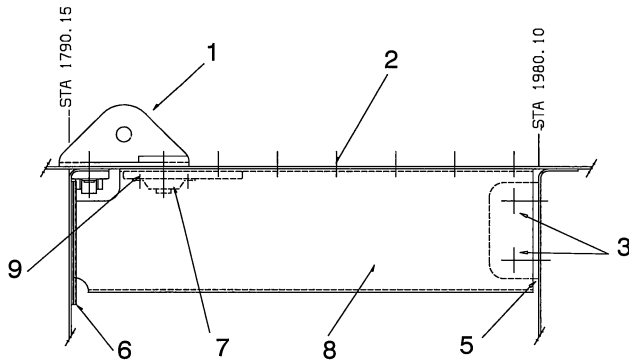

VIEW D
Showing the Cabin Floor Modifications

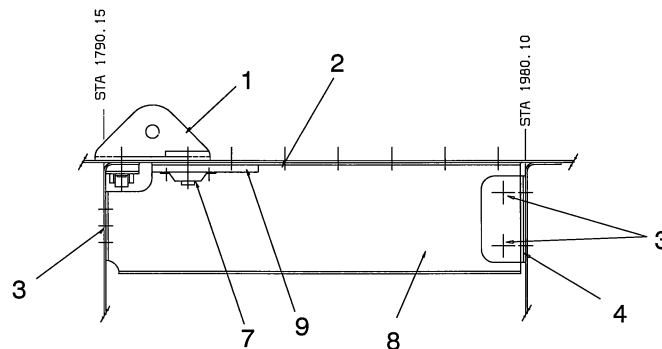

VIEW E
Showing the Cabin Floor Modifications

Figure 8 Cabin Floor Modifications Continued

Transport Canada Accepted

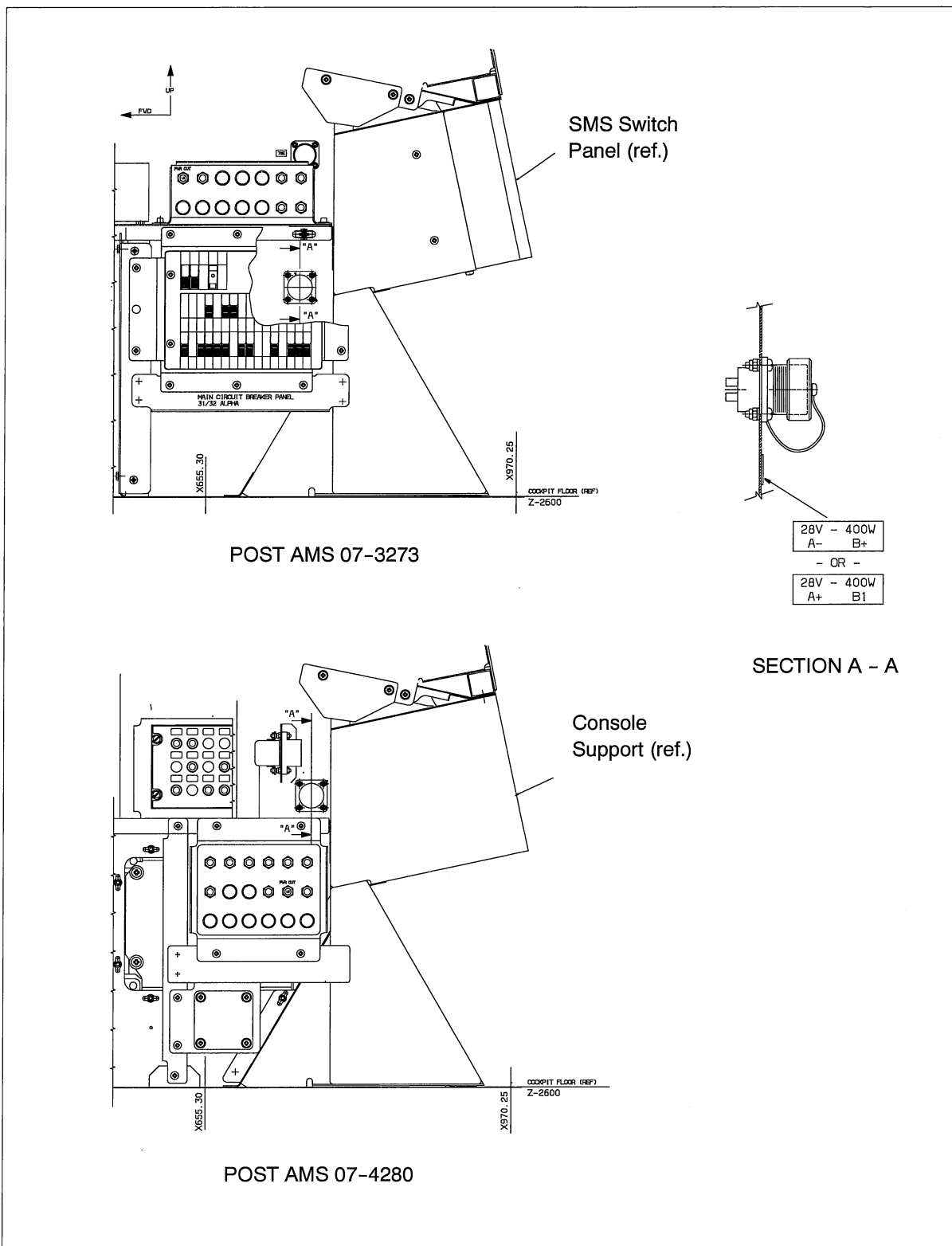

Figure 9 Utility Power Plug Relocation

Transport Canada Accepted

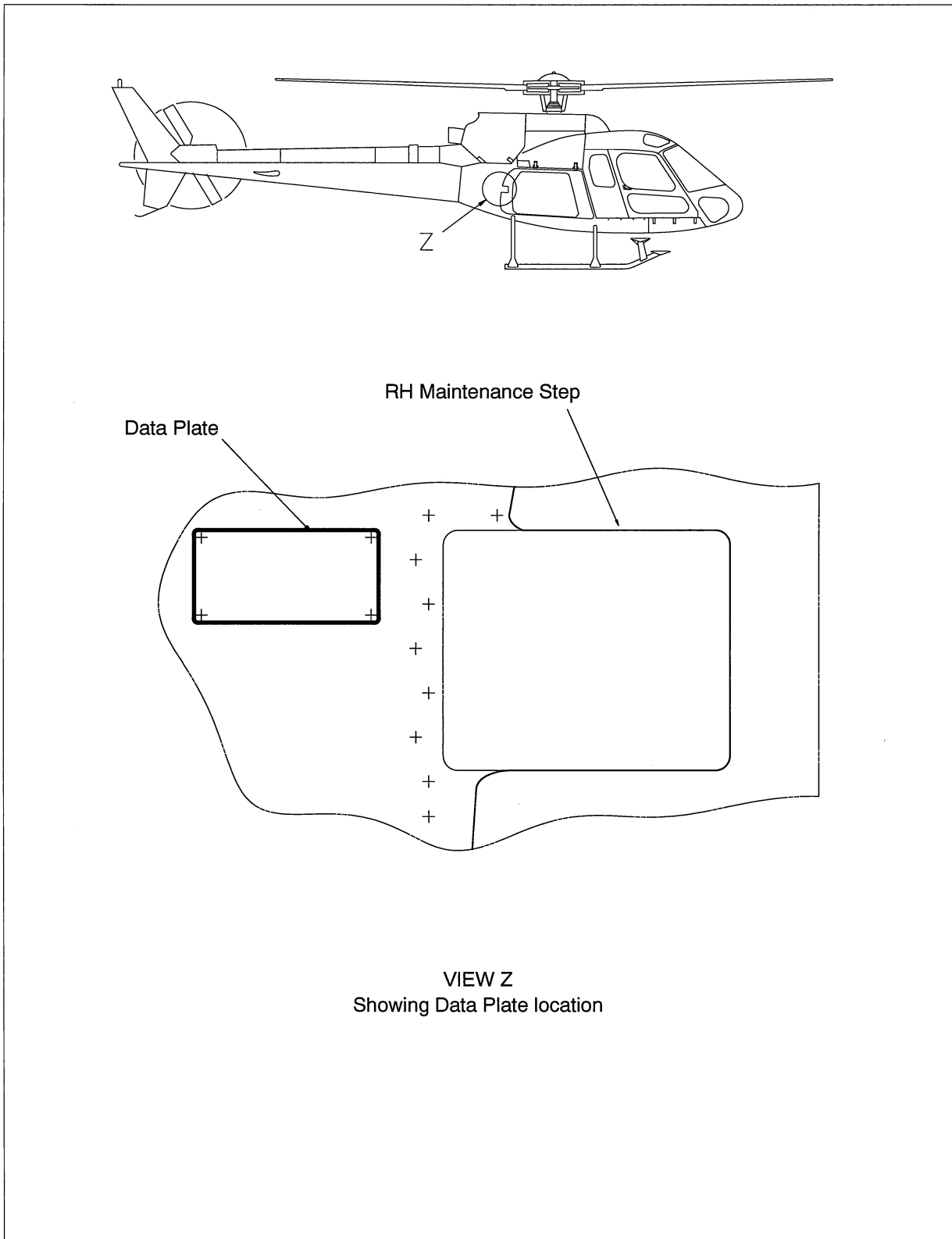

Figure 10 Data Plate relocation

Transport Canada Accepted



C. REFERENCES

DOCUMENT	DOCUMENT TITLE
AMM	Aircraft Maintenance Manual
AMS 07 3274	Avis de Modification Serie 07 3274
ICA	Instructions for Continued Airworthiness
MET	Maintenance Manual
MTC	Standard Practices Manual

D. ABBREVIATIONS AND DEFINITIONS

ABBREVIATION	DEFINITION
assy	assembly
BL	Butt Line
D	Days
EC	Eurocopter (France)
ECL	Eurocopter Canada Limited
FH	Flight Hours
hrs	hours
iaw	in accordance with
L	Left
M	Months
MDL	Master Drawing List
P/N	Part Number
Pt.	part
ref.	reference
R	Right
STC	Supplemental Type Certificate
STN	Station
TCCA	Transport Canada Civil Aviation

E. UNITS OF MEASUREMENT

ABBREVIATION / SYMBOL	UNIT OF MEASUREMENT
in	inch
kg	kilogram
kg/m ²	kilogram/meter squared
lbs	pounds
m	meter
m kg	meter kilogram

Transport Canada Accepted



EUROCOPTER
CANADA
AN EADS COMPANY

**INSTRUCTIONS FOR CONTINUED
AIRWORTHINESS
TWO PLACE FORWARD PASSENGER SEAT
AS 350 BA, B2, B3**

2. AIRWORTHINESS LIMITATIONS

The Airworthiness Limitations section is approved by the Minister and specifies maintenance required by any applicable airworthiness or operating rule unless an alternative program has been approved by the Minister. Variations must also be approved.

The Airworthiness Limitations section is FAA approved and specifies inspections and other maintenance required under Sections 43.16 and 91.403 of the Federal Aviation Regulations unless an alternative program has been FAA approved.

There is a 10 year life limitation from the date of manufacture on each of the Seat Belt Assemblies.

Transport Canada Accepted



3. CONTROL AND OPERATION

Control and operation of the aircraft remains unchanged.

NOTE: The Installation of Dual Controls is prohibited.

4. INSPECTION SCHEDULE AND MAINTENANCE ACTION

NOTE: Use torque per MTC, Volume 2, Chapter 20.02.05.404, unless otherwise specified.

4.1. INSPECTION SCHEDULE

4.1.1. Every 150 FH or 12 M (Margin: 15 FH or 36 D) to coincide with the 150 FH or 12 M helicopter inspection, whichever occurs first:

ITEM	INSPECTION OR MAINTENANCE WORK	CORRECTIVE ACTION
A	<ul style="list-style-type: none"> - Visually inspect Seat Belt Assembly, in Figure 1, for: <ul style="list-style-type: none"> a. excessive wear (visible fading, fraying, cuts, etc.) b. legibility of seat belt identification label c. check label for 10 year life limit requirements d. Check inertia reels for correct operation (proper locking when pulled abruptly) 	<ul style="list-style-type: none"> a. Excessive wear is not permitted. If excessive wear is evident, contact Eurocopter Canada Limited for replacement parts. b. If no longer legible, contact Eurocopter Canada Limited. c. Replace belt if 10 year life limit is met. d. If not operating correctly, contact Eurocopter Canada Limited for corrective action.
B	<ul style="list-style-type: none"> - Visually inspect all mounting hardware in Figure 2, for: <ul style="list-style-type: none"> a. security 	<ul style="list-style-type: none"> a. Re-tighten as required
C	<ul style="list-style-type: none"> - Visually inspect seat rail, item 1, shown in Figure 6, for: <ul style="list-style-type: none"> a. damage at seat attachment locations 	<ul style="list-style-type: none"> a. If damage is detected replace damaged rail.
D	<ul style="list-style-type: none"> - Visually inspect Two Place Forward Passenger Seat, in Figure 5, for: <ul style="list-style-type: none"> a. general condition 	<ul style="list-style-type: none"> a. If cracking, delamination or debonding is found, contact Eurocopter for corrective action.
E	<ul style="list-style-type: none"> - Visually inspect intercostals under cabin floor as shown in Figures 7 & 8, for: <ul style="list-style-type: none"> a. cracks or corrosion 	<ul style="list-style-type: none"> a. No cracks or corrosion are allowed. If cracks or corrosion are found, contact ECL for replacement parts. Refer to Section 8 for removal and replacement of intercostals.

Table 1 Inspection Schedule and Maintenance Action
Every 150 FH or 12 M to coincide with the 150 FH or 12 M helicopter inspection, whichever occurs first

Transport Canada Accepted



4. INSPECTION SCHEDULE AND MAINTENANCE ACTION (continued)

4.1. INSPECTION SCHEDULE

4.1.1. Every 150 FH or 12 M (Margin: 15 FH or 36 D) to coincide with the 150 FH or 12 M helicopter inspection, whichever occurs first:

ITEM	INSPECTION OR MAINTENANCE WORK	CORRECTIVE ACTION
F	<ul style="list-style-type: none"> - Check placards and markings (refer to Section 10) for: <ul style="list-style-type: none"> a. legibility b. secure mounting 	<ul style="list-style-type: none"> a. If placard has become illegible, contact Eurocopter Canada Limited for replacement part. b. Secure, reattach placards as required.

Table 1 Inspection Schedule and Maintenance Action
Every 150 FH or 12 M to coincide with the 150 FH or 12 M helicopter inspection, whichever occurs first

5. REPLACEMENT COMPONENTS AND REPAIR / OVERHAUL INFORMATION

No replacement components and repair / overhaul information required for this installation.

Transport Canada Accepted



6. TROUBLESHOOTING

For electrical system troubleshooting the Utility Power Plug Relocation, refer to Figure 11, Wiring Diagram.

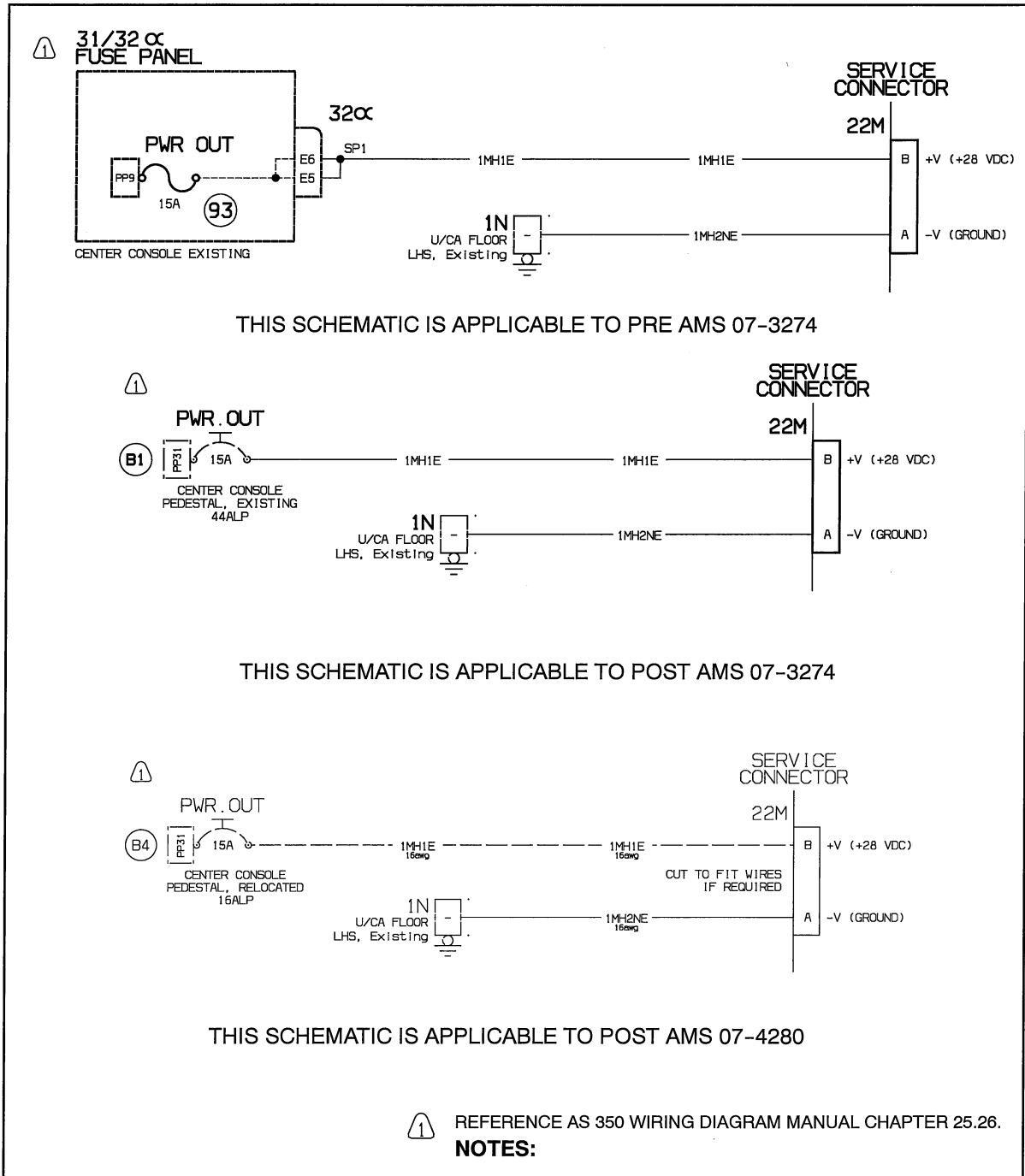

Figure 11 Wiring Diagram, Utility Power Plug Relocation

Transport Canada Accepted



7. SPECIAL TOOLING

No special test equipment or tools are required. Standard tools are adequate.

8. REMOVAL AND REPLACEMENT

PRELIMINARIES - if removing/replacing the Floor Mat

A. For aircraft AS 350 B2 and B3:

- Read General Safety Instructions - Electrical Power Supply System (refer to AS 350 B2/B3 AMM, Chapter 24-00-00, 3-1)
- Read Electrical Power Supply on the Ground (refer to AS 350 B2/B3 AMM, Chapter 24-00-00, 2-1)
- disconnect the external power unit and battery (refer to Removal/Installation, AS 350 B2/B3 AMM, Chapter 24-33-00, 4-1)
- Read and comply with general safety instructions for the mechanical assemblies, AMM, Chapter 60-00-00, 3-1

B. For aircraft AS 350 (excluding AS 350 B2 & B3)

- Read the General Electrical Instructions (refer to AS 350 MET, Chapter 24.00.00.301)
- set the "D.BAT" push button to "OFF"
- set the "EXT PWR BAT" pushbutton to "OFF" (refer to Electrical Power, General Instructions, AS 350 MET, Chapter 24.00.00.301)
- disconnect the external power unit and battery (refer to Removal/ Installation AS 350 MET, Chapter 24.30.00.401)
- Read Rotors - General Instructions, MET, Chapter 60.00.00.301

C if replacing an intercostal, remove intermediate fairings and pull floor covering back

Transport Canada Accepted

8. REMOVAL AND REPLACEMENT (continued)

General Repair Instructions Unriveting principal, refer to MTC, Chapter 20-03-01,102.

A. REMOVAL

- 1) TWO PLACE FORWARD PASSENGER SEAT (Refer to Figure 2)
 - a) Disengage spring pins (1, 3 places) from front attachment under seat.
 - b) Disconnect lap belts from cabin floor.
 - b) Slide seat to free studs (9, 3 places) from track and remove double seat assembly.
- 2) SEAT RAILS (Long Rails) (Refer to Figure 6)
 - a) Remove screws (2, 5 places) securing the seat rail to the cabin floor. Retain hardware for reinstallation.
- 3) INTERCOSTAL (located under long seat rail) (Refer to Figures 6 and 7)
 - a) Remove seat rail.
 - b) Remove existing rivets securing intercostal (8) to the cabin floor, aircraft frame and clip (6).
- 4) SEAT RAIL (Short Rail) (Refer to Figure 6)
 - a) Remove screws (2, 4 places) securing the shorter seat rail to the cabin floor. Retain hardware for reinstallation.
- 5) SEAT BELT BRACKET ASSEMBLY (Refer to Figure 4)
 - a) Remove seat belt attachment from ring (1, 3 places).
 - b) Remove screws (6, 3 places), washers (5, 3 places) and profile washer (7) securing the seat belt assembly bracket (2) to the cabin floor. Retain hardware for reinstallation.
- 6) INTERCOSTAL (under seat belt bracket assembly) (Refer to Figure 8)
 - a) Remove seat belt bracket assembly.
 - b) Remove existing rivets securing intercostal (8) to cabin floor, aircraft frame and clip (5).

Transport Canada Accepted



8. **REMOVAL AND REPLACEMENT** (continued)

B. REPLACEMENT

Replacement of rivets: General, refer to MTC, Chapter 20-03-02, 101.

NOTE: Use torque per MTC, Volume 2, Chapter 20.02.05.404, unless otherwise specified.

- 1) INTERCOSTAL (located under long seat rail) (Refer to Figures 6 and 7)
 - a) Mark center line on upper lip of intercostal (8). Mark center line through previously drilled holes in cabin floor.
 - b) Position intercostal (8) below cabin floor and mark two outer pilot holes through cabin floor onto lip of intercostal.
 - c) Remove intercostal and drill pilot holes.
 - d) Reinstall intercostal into position and secure to cabin floor using cleco pins.
 - e) Match drill remaining holes from cabin floor into intercostal.
 - f) Match drill holes from clip (6) into intercostal. Remove intercostal from aircraft and place on work bench.
 - g) Match drill holes for 4 anchor nut locations into intercostal.
 - h) Position profile washer (9) and match drill holes from intercostal for anchor nut (7). Secure profile washer (9) and anchor nut (7) to underside of intercostal using rivets (4).
 - i) Install remaining anchor nuts (7, 4 places) using rivets (4, 8 places) to underside of intercostal upper lip.
 - j) Reposition intercostal in aircraft under cabin floor and secure using rivets (2, 4 places), rivets (3, 15 places) and rivets (5, 6 places).
- 2) SEAT RAILS (Long Rails) (Refer to Figure 6)
 - a) Reposition seat rail on cabin floor and secure using screws (2, 5 places)
- 3) SEAT RAILS (Short Rails) (Refer to Figure 6)
 - a) Reposition seat rail on cabin floor and secure using screws (2, 4 places)
- 4) SEAT BELT BRACKET ASSEMBLY (Refer to Figure 4)
 - a) Reposition seat belt assembly bracket (2) and secure using screws (6, 3 places), washers (5, 3 places) and profile washer (7)
 - b) Reattach seat belt to attachment ring (1, 3 places).

Transport Canada Accepted



8. REMOVAL AND REPLACEMENT (continued)

B. REPLACEMENT (continued)

5) INTERCOSTAL (under seat belt bracket assembly) (Refer to Figure 8)

- a) Mark center line on upper lip of intercostal (8). Mark center line through previously drilled holes in cabin floor.
- b) Position intercostal (8) below cabin floor and mark two outer pilot holes through cabin floor onto lip of intercostal.
- c) Remove intercostal and drill pilot holes.
- d) Reinstall intercostal into position and secure to cabin floor using cleco pins.
- e) Match drill remaining holes from cabin floor into intercostal.
- f) Match drill holes from clip (5) into intercostal. Remove intercostal and deburr holes.
- g) Reposition intercostal in aircraft under cabin floor, reposition profile washer (9) and secure to cabin floor using rivets (2, 6 places), to clip (5) and aircraft frame using rivets (3, 5 places).

6) TWO PLACE FORWARD PASSENGER SEAT (Refer to Figure 2)

- a) Reposition floor covering.
 - b) Carefully align double seat assembly studs (9, 3 places) and front attachment into track.
 - c) Secure double seat assembly to front attachment by engaging spring pins (1, 3 places).
 - d) Reconnect lap belts to cabin floor.
- 7) Close all areas opened for service in the PRELIMINARIES paragraph of this section.
- 8) Reinstall intermediate fairing.

For aircraft AS 350 B2 and B3:

- 1) Before energizing the aircraft power supply system, read to General Safety Instruction – Electrical Power Supply System, AS 350 B2/B3, AMM, Chapter 24-00-00, 3-1).
- 2) Reconnect the external power unit and battery Refer to Removal/Installation AS 350 B2/B3 AMM, Chapter 24-33-00, 4-1.
- 2) Perform functional test – DC Power Supply System in accordance with AS 350 B2/B3 AMM, Chapter 24-30-00-5-1.

For aircraft AS 350 (excluding AS 350 B2 and B3)

- 1) Apply external power unit and battery. Refer to AS 350 MET, Chapter 24.30.00.501.
- 2) Perform functional test in accordance with AS 350 MET, Chapter 24.30.00.501.

Transport Canada Accepted



9. WEIGHT AND BALANCE DATA

A. Removed Items

DESCRIPTION	WEIGHT		ARM		MOMENT	
	kg	lbs	m	in	m.kg	in.lb
Fwd Seat	-12.25	-27.0	1.57	61.8	-19.23	-1668.6
Total	-12.25	-27.0	1.57	61.8	-19.23	-1668.6

B. Added Items

DESCRIPTION	WEIGHT		ARM		MOMENT	
	kg	lbs	m	in	m.kg	in.lb
Cabin Floor MOD	0.79	1.7	1.65	65.0	1.30	110.5
Double Seat Complete	14.06	31.0	1.70	66.9	23.90	2073.9
Seat Belt Bracket Assembly	0.15	0.3	1.82	71.7	0.27	21.5
Long Seat Rails (qty. 2)	0.52	1.1	1.65	65.0	0.86	71.5
Short Seat Rail (qty. 1)	0.20	0.4	1.70	66.9	0.34	26.8
Hardware	0.25	0.6	1.65	65.0	0.41	39.0
Total	15.97	35.1	1.70	66.8	27.09	2343.2

Transport Canada Accepted



10. PLACARDS AND MARKINGS

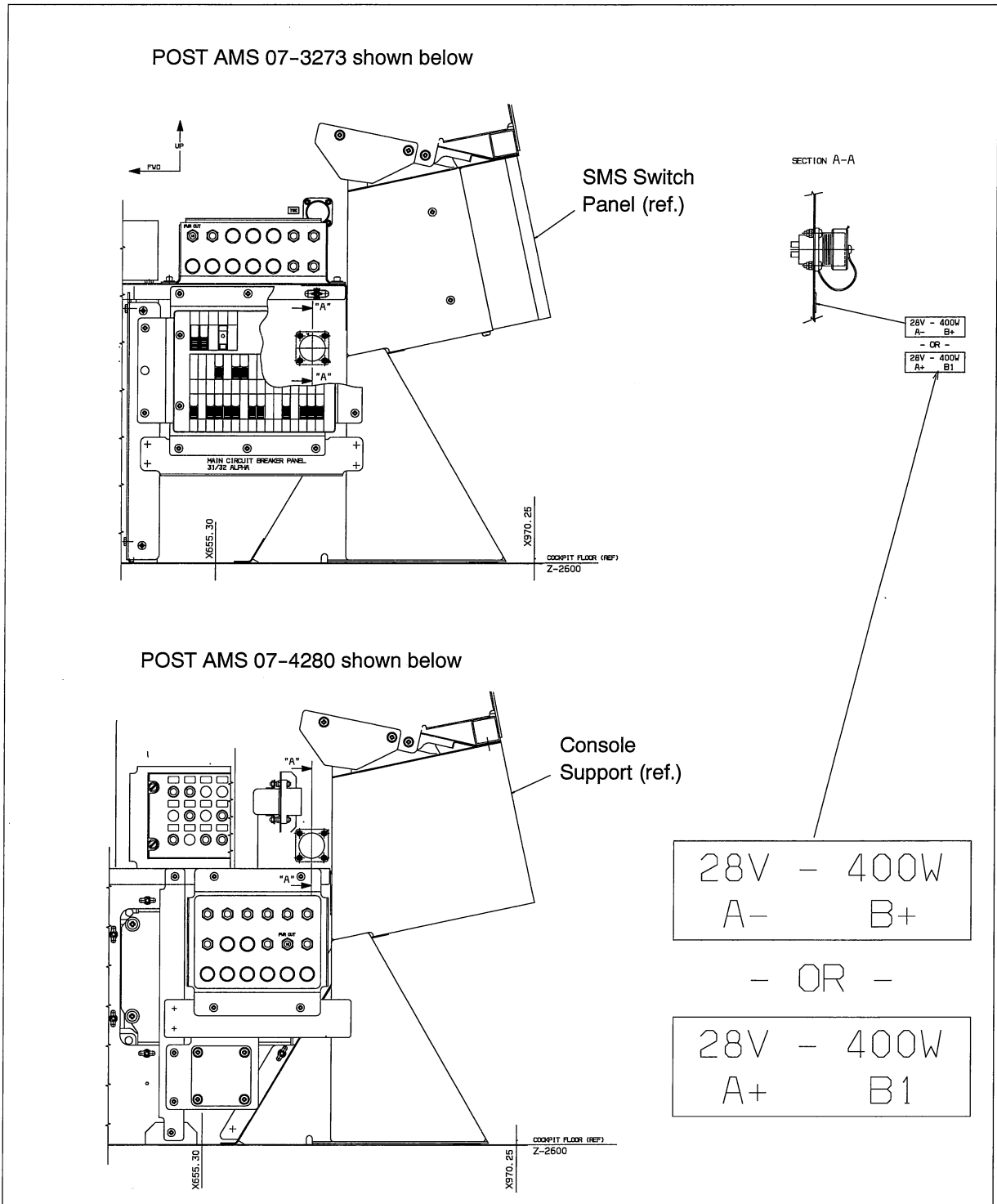

Figure 12 Identification label location in nosebay (POST AMS 07-3273 & POST AMS 07-4280)

Transport Canada Accepted



10. **PLACARDS AND MARKINGS** (continued)

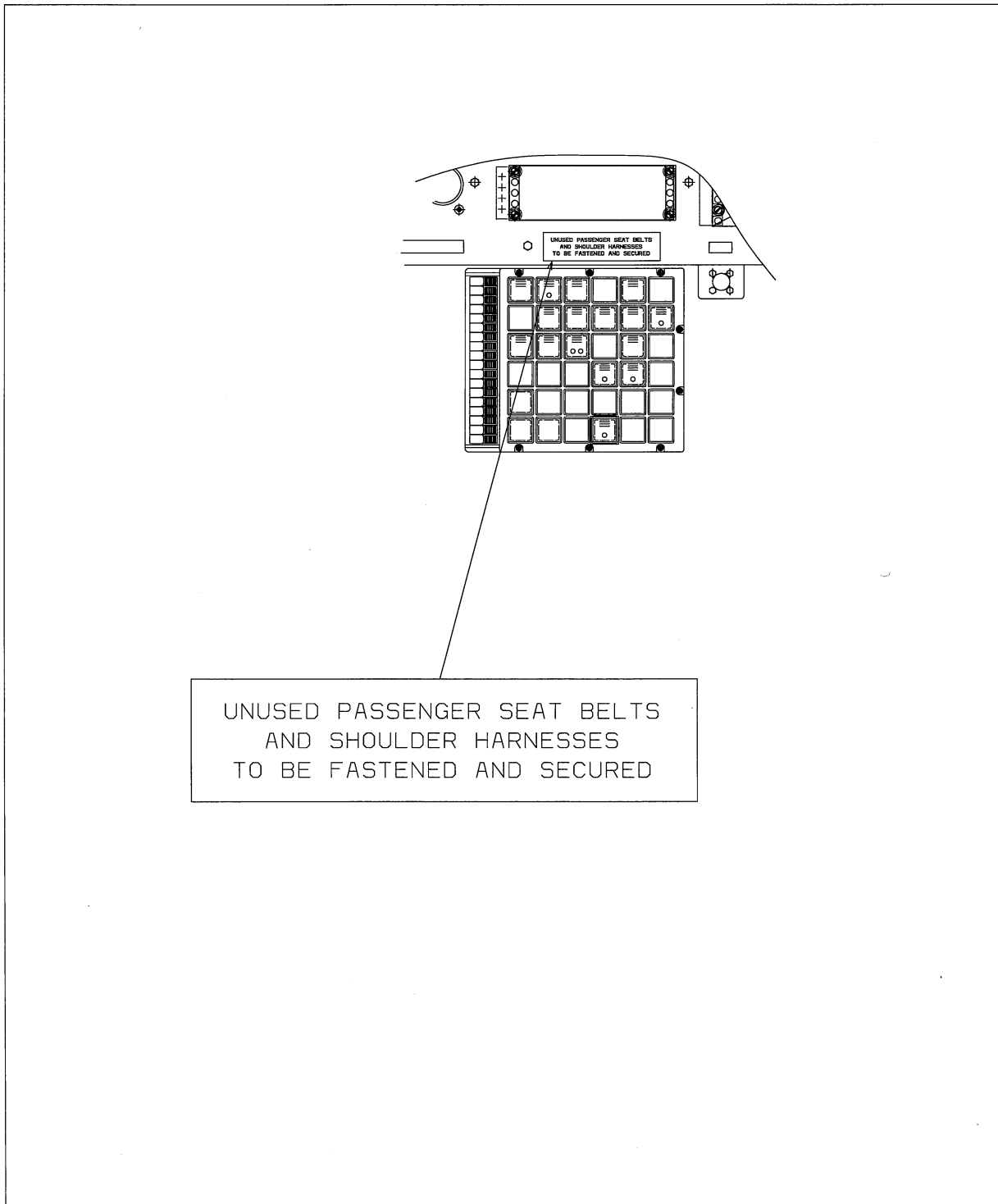

Figure 13 Typical location of placard on Instrument Panel

Transport Canada Accepted