



**INSTRUCTIONS FOR CONTINUED
AIRWORTHINESS
STANDARD INTERIOR MODIFICATION
SEAT COVER
AS 350 / AS 355**

AIRBUS HELICOPTERS CANADA LIMITED



SUBJECT:

Required maintenance for Standard Interior Modification, Seat Cover
(P/N 350-701904).

APPLICABILITY :

Aircraft with the subject modification embodied in accordance with TCCA STC
No. SH12-28 or any relevant foreign approvals.

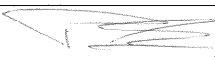
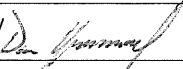
THE INFORMATION CONTAINED IN THIS DOCUMENT SHALL BE TREATED AS THE PROPERTY OF AIRBUS HELICOPTERS CANADA LIMITED (AHCA). THE RECIPIENT OF THIS DOCUMENT SHALL NOT DISCLOSE ANY INFORMATION CONTAINED HEREIN TO THIRD PARTIES WITHOUT THE WRITTEN PERMISSION OF AHCA, AND SHALL NOT USE OR REPRODUCE THIS DOCUMENT IN WHOLE OR IN PART FOR ANY PURPOSE OTHER THAN ITS ORIGINALLY INTENDED PURPOSE, OR TO EVALUATE ITS CONTENTS.

	NAME AND SIGNATURE	DATE	COMPANY DEPARTMENT
PREPARED BY:	D. Kerr 	9 Mar, 2018	AHCA ENGINEERING
PREPARED BY:			
CHECKED BY:	P. Sharpe 	9 Mar 2018	AHCA ENGINEERING
CHECKED BY:	D. Kapuscinsky 	12 MAR 2018	AHCA QUALITY ASSURANCE
REV 5 ACCEPTED (Civil A/W Authority)	(As per ICA Compliance Check Sheet) 	MAR 21 2018	TCCA
REV 5 RELEASED BY:	P. Sharpe 	MAR 21 2018	AHCA ENGINEERING

RECORD OF REVISIONS

Rev.	Pages at this Revision	Description, Reason Changed Pages	Prepared (name and date)	Checked (name and date)	App'd/Acc'd (Civil A/W Authority) (name and date)	Released (name and date)
0	1 through 20 A1 to A2 B1 C1 to C3 D1 to D21	See page 1.	D. Kerr 23 March 2012	C. Timmins 23 March 2012	N/A	R. Manson 2 April 2012
1	1 through 20 A1 to A2 B1 C1 to C3 D1 to D21	Revision to text and drawing. (Pages 15, 16 and Appendix A, page 1 of 2)	D. Kerr 2 April 2012	C. Timmins 2 April 2012	TCCA K. Chan 5 April 2012	R. Manson 11 April 2012
2	1 through 20 A1 to A2 B1 C1 to C3 D1 to D21	Revised seat configuration chart. Corrections made to Weight and Balance Charts. (Pages 3, 4, 15, 16, 18 to 20)	D. Kerr 31 August 2012	R. Manson 31 August 2012	N/A	R. Manson 31 October 2012
3	1 through 20 A1 to A2 B1 C1 to C3 D1 to D21	Reference to Appendix D corrected in Section 8. Drawing revised. (Page 15)	D. Kerr 31 October 2012	C. Timmins 31 October 2012	TCCA G. David 1 November 2012	R. Manson 5 November 2012
4	1 through 20 A1 to A2 B1 C1 to C1 D1 to D21	Addition of company logo, name change and template change. Addition of AS 355 aircraft type to document. Chapter reference in Section 4 revised. (Pages 3 to 11 and 13 to 16)	D. Kerr 4 Sept 2014	C. Timmins 4 Sept, 2014	TCCA G. David 11 Nov, 2014	P. Sharpe 11 Nov 2014
5	1 through 21 A1 to A2 B1 C1 to C3 D1 to D21	Nylon strap added to -02,-04,-05 and -06 Part No.'s Rear back cushions -08 added for SICMA 198 seat; Figure 9 Views reassigned. Seat type changed to SICMA 159 or 198; Appendix A deleted (Pages 3 to 13 and 15 to 21)	See Page 1	See page 1	See page 1	See page 1

NOTE: Revisions to this document will be distributed to operators of this equipment by the STC holder.

NOTE: Revised portions of affected pages are identified by a vertical black line in the margin adjacent to the change.

NOTE: Minor changes are released in accordance with TCCA - ACCEPTED CAR 521.154 procedures (ref. DAPM-E-0001).

Transport Canada - Accepted



AIRBUS HELICOPTERS CANADA LIMITED

INSTRUCTIONS FOR CONTINUED
AIRWORTHINESS
STANDARD INTERIOR MODIFICATION
SEAT COVER
AS 350 / AS 355

CONTENTS

SECTION	TITLE	PAGE
1	GENERAL	4
2	AIRWORTHINESS LIMITATIONS	15
3	CONTROL AND OPERATION	16
4	INSPECTION SCHEDULE AND MAINTENANCE ACTION	16
5	REPLACEMENT COMPONENTS AND REPAIR / OVERHAUL INFORMATION	17
6	TROUBLESHOOTING	17
7	SPECIAL TOOLING	17
8	REMOVAL AND REPLACEMENT	18
9	WEIGHT AND BALANCE DATA	20
10	PLACARDS AND MARKINGS	21
Appendix A	deleted (2 pages)	
Appendix B	Fabric Seat Cover cleaning information (1 page)	
Appendix C	Leather Seat Cover cleaning information (1 page)	
Appendix D	Lumbar Support cleaning information (21 pages)	

FIGURES

FIGURE	TITLE	PAGE
1	General Layout	5
2	Forward Seat Cover Details for SICMA 159 Series Seat	6
3	Forward Seat Cover Details for SICMA 159 Series Seat (continued)	7
4	Rear Seat Cushion Details for 350- 701904- 02	8
5	Rear Seat Cushion Details for 350- 701904- 02 (continued)	9
6	Rear Seat Cover Details for 350- 701904- 04 & - 05	10
7	Rear Seat Cover Details for 350- 701904- 06	11
8	Rear Seat Cover Details for 350- 701904- 06 (continued)	12
9	Forward Seat Cover Details for SICMA 198 Series Seat	13

TABLES

TABLE	TITLE	PAGE
1	Inspection Schedule and Maintenance Action Every 150 FH or 12 M (Margins: 15 FH or 36 D)	16

Transport Canada - Accepted

1. GENERAL

- A. The subject Standard Interior Modification for the Seat Cover is defined by AHCA drawing number 350-701904 and consists of the following seat cover configurations:

Description	Part Number	OEM Cushion Part Number
Forward Seat Cover (SICMA 159)	350-701904-01	P/N 159700-1
Rear Seat Cover	350-701904-02	P/N 350A771412.21 & 350A771412.20
Forward Seat Cover (SICMA 159)	350-701904-03	P/N F0428848
Rear Seat Back Cover	350-701904-04	P/N 350A771412.11
Rear Seat Back Cover	350-701904-05	P/N 350A771412.12
Rear Seat Bottom Cover	350-701904-06	P/N 350A771412.10
Forward Seat Cover (SICMA 198)	350-701904-08	P/N F0447770

The forward and rear seat covers are manufactured from customer defined polyester fabric or leather. These seat covers may be utilized as an alternate to the standard seat covers.

The forward seat covers are manufactured to fit the OEM foam used on the energy-absorbing type seats: SICMA 159 or SICMA 198 Series for AS 350, and SICMA 159 Series for AS 355. The cushions are secured to the seat frame using snaps and velcro hook and loop.

Two strap holders manufactured from the customer defined material are attached to the back of the rear back seat cover. Two OEM cushion security straps feed through the strap holders securing the rear back seat covers to the cabin wall. Velcro loop on the back of the rear back seat cushion secures the cushion to the existing velcro hook on the back wall. The security straps and velcro hook and loop are used to prevent the rear cushions from exiting the aircraft when operating the aircraft with the doors open or removed.

The rear back and bottom cushions are secured together using Velcro. The rear bottom cushions are secured to the seat frame using velcro hook and loop.

Refer to Figure 1 for General Layout.

- B. These Instructions for Continued Airworthiness are applicable to aircraft with the subject modification embodied.

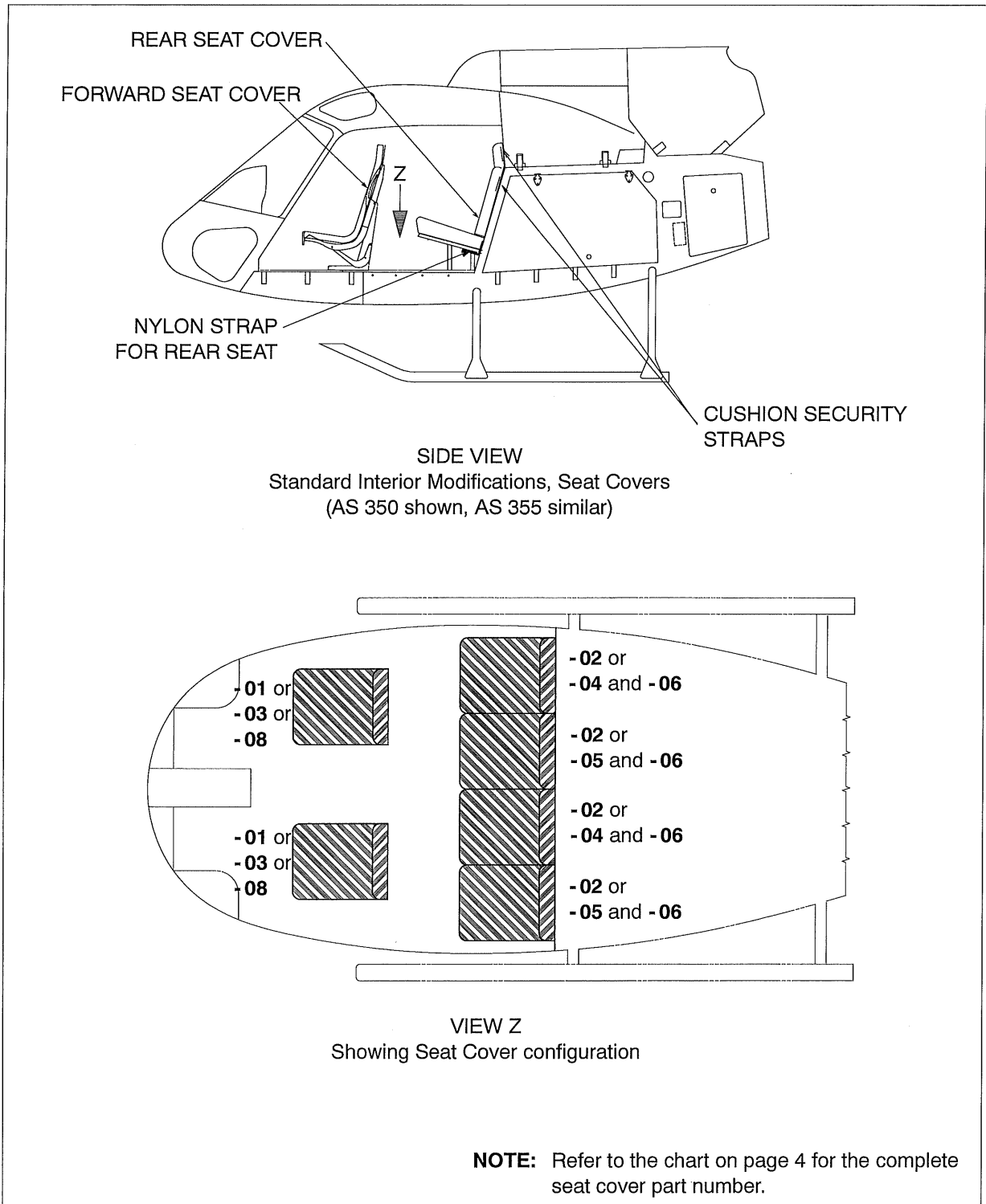

Figure 1 General Layout

Transport Canada - Accepted

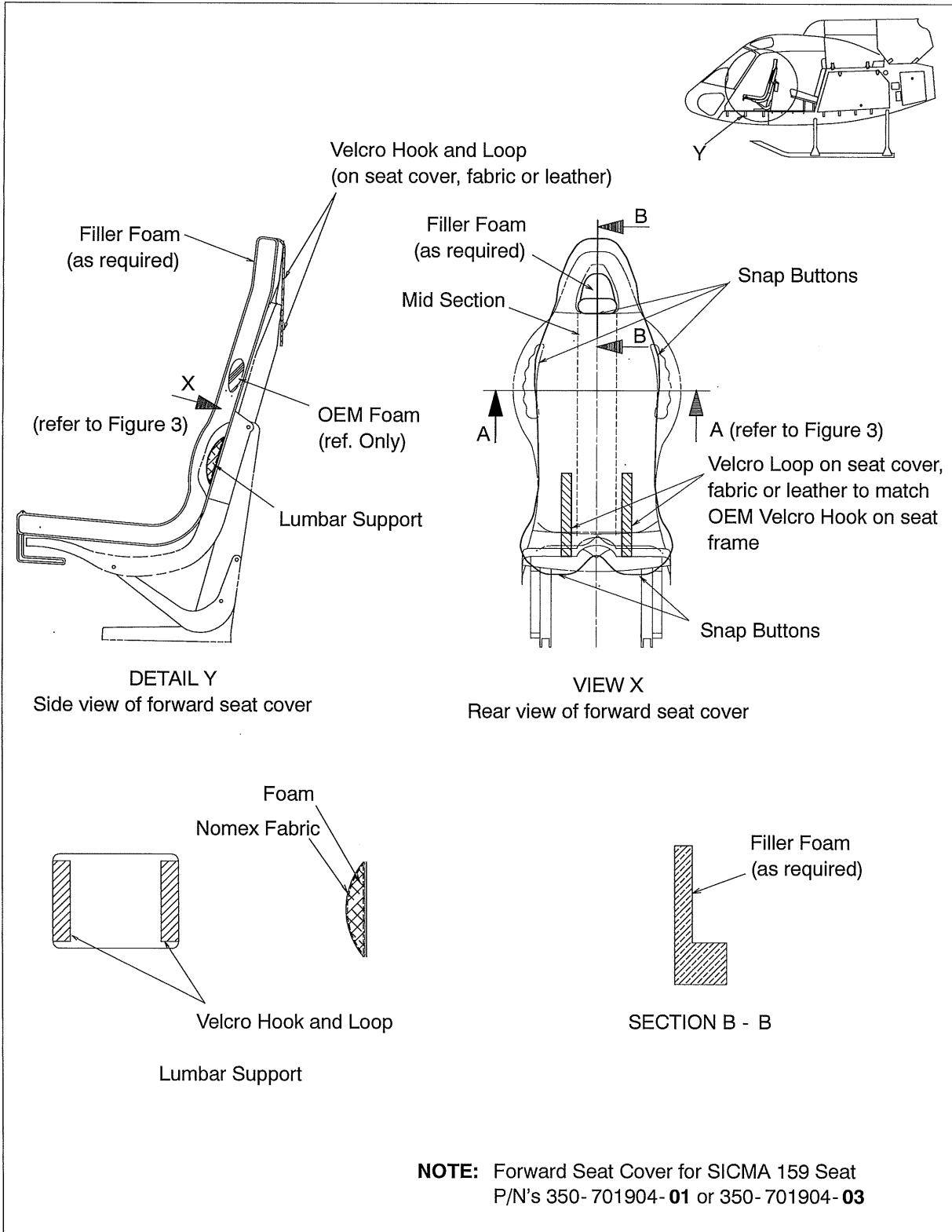

Figure 2 Forward Seat Cover Details for SICMA 159 Series Seat

Transport Canada - Accepted

AIRBUS HELICOPTERS CANADA LIMITED
Legend (for Figure 3)
Item Description

1. Fabric or Leather Seat Cover
2. Perforated Leather (in mid section only)
3. Foam (as required)
4. Backing Cloth
5. T-Braid Seaming Cord
6. Snap Buttons

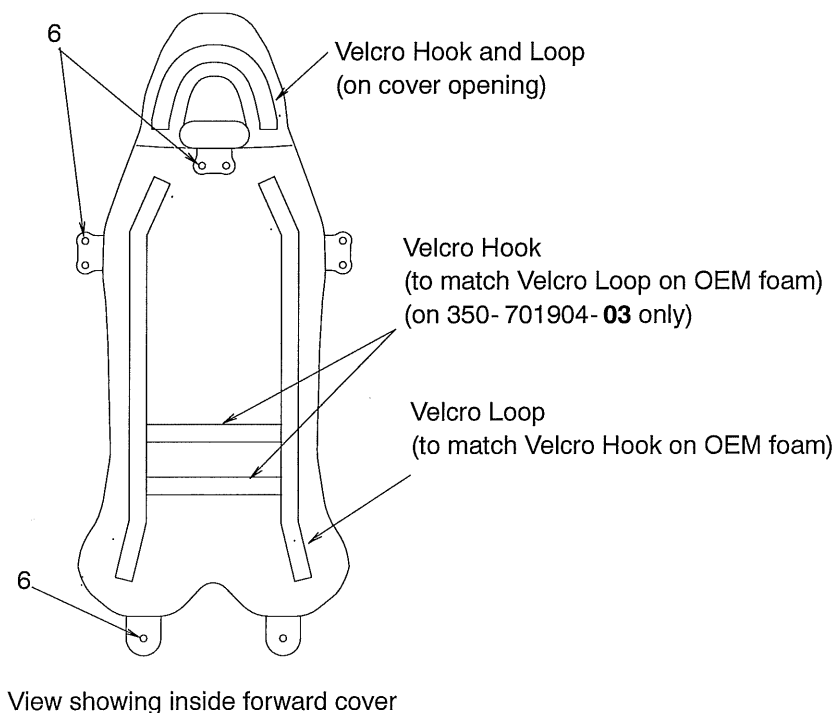
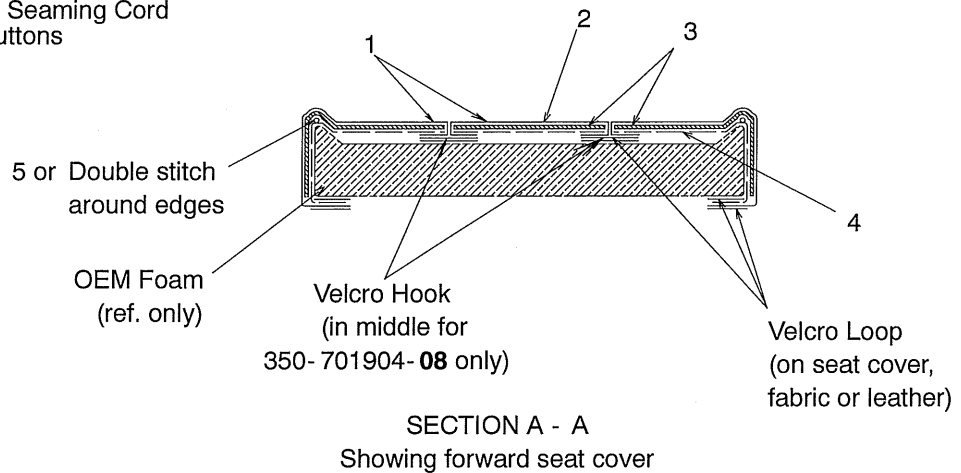

Figure 3 Forward Seat Cover Details for SICMA 159 Series Seat (continued)

Transport Canada - Accepted

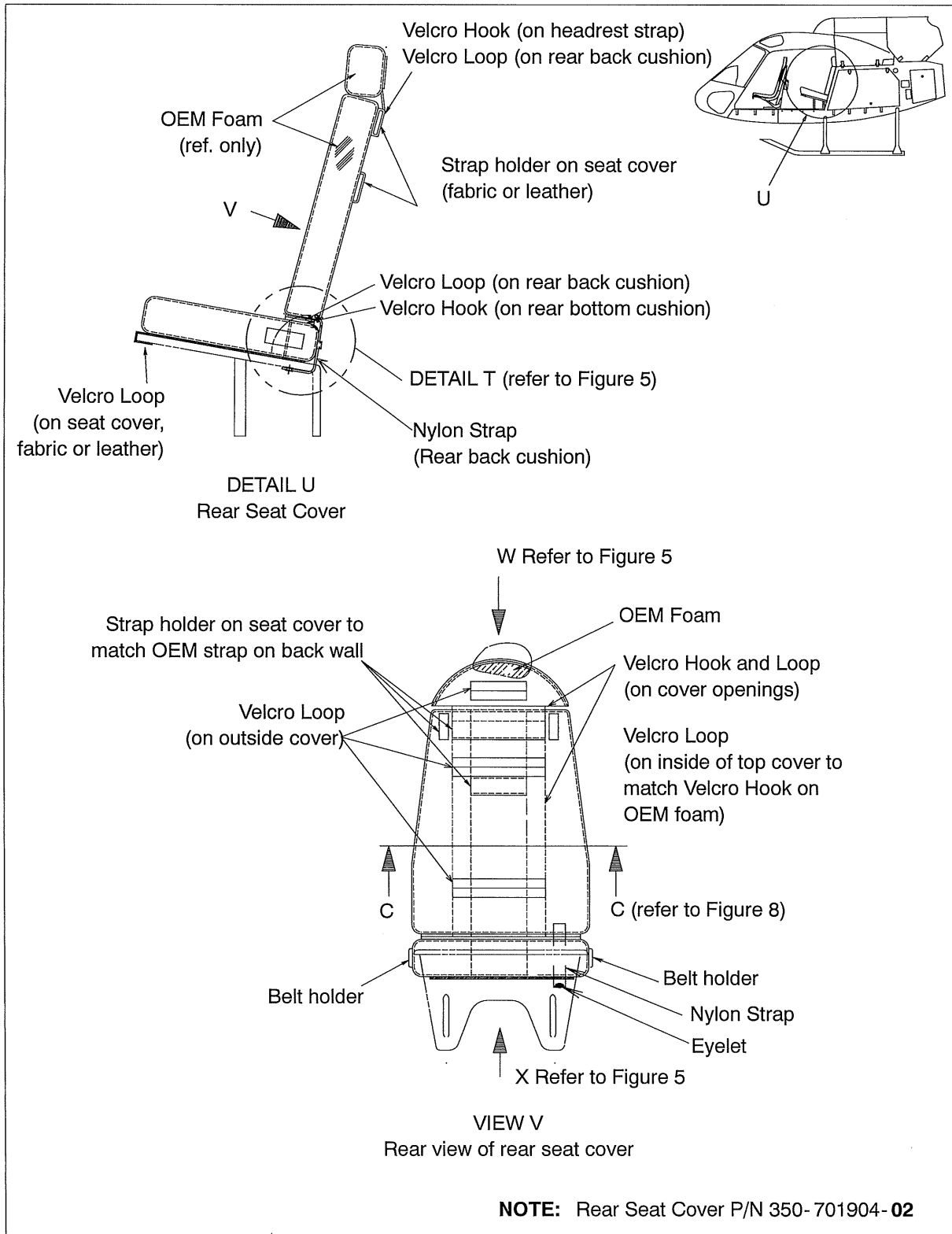
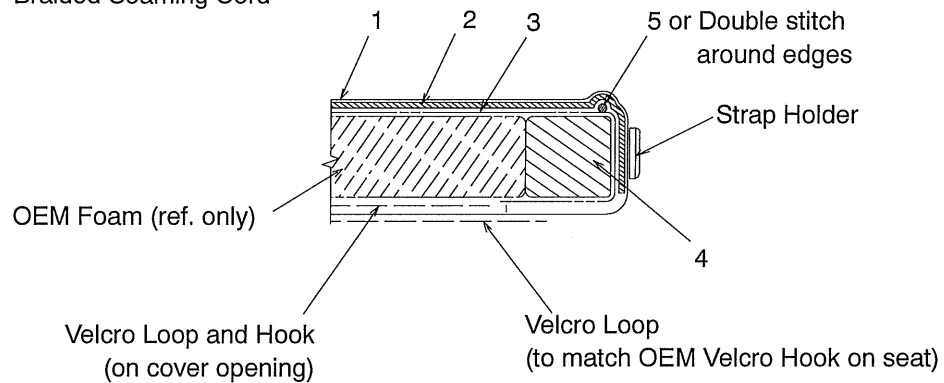

Figure 4 Rear Seat Cover Details for 350-701904-02

Transport Canada - Accepted

Legend (for Figure 5)
Item Description

1. Fabric, Leather or Perforated Leather Seat Cover
2. Padding Foam (as required)
3. Cloth Backing
4. Foam
5. T-Braided Seaming Cord



DETAIL T
 For rear bottom cushion

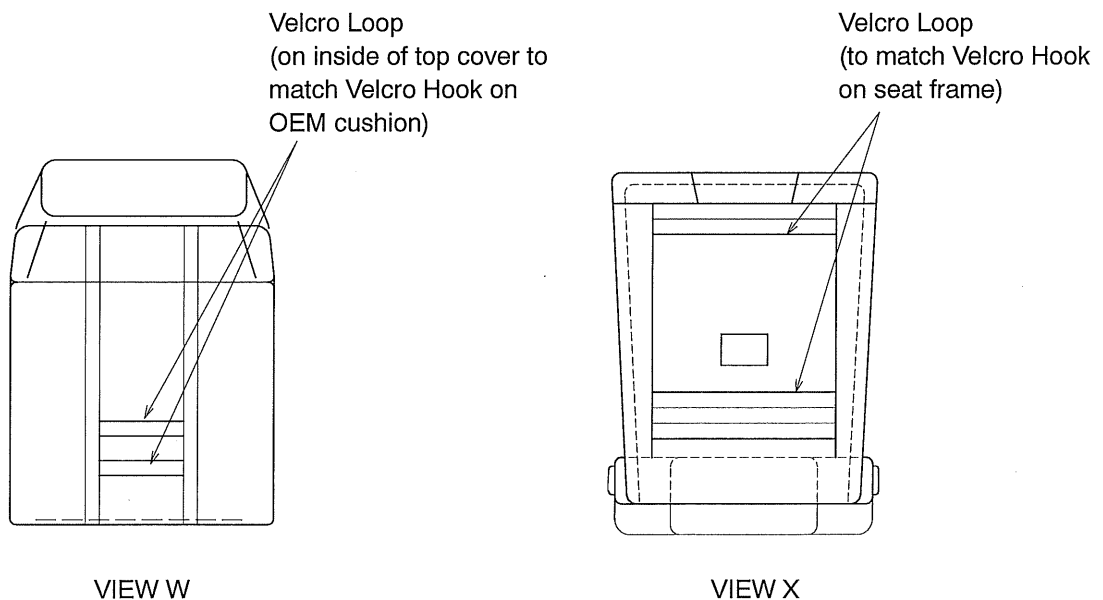

NOTE: Rear Seat Cover P/N 350-701904-02

Figure 5 Rear Seat Cover Details for 350-701904-02 (continued)

Transport Canada - Accepted

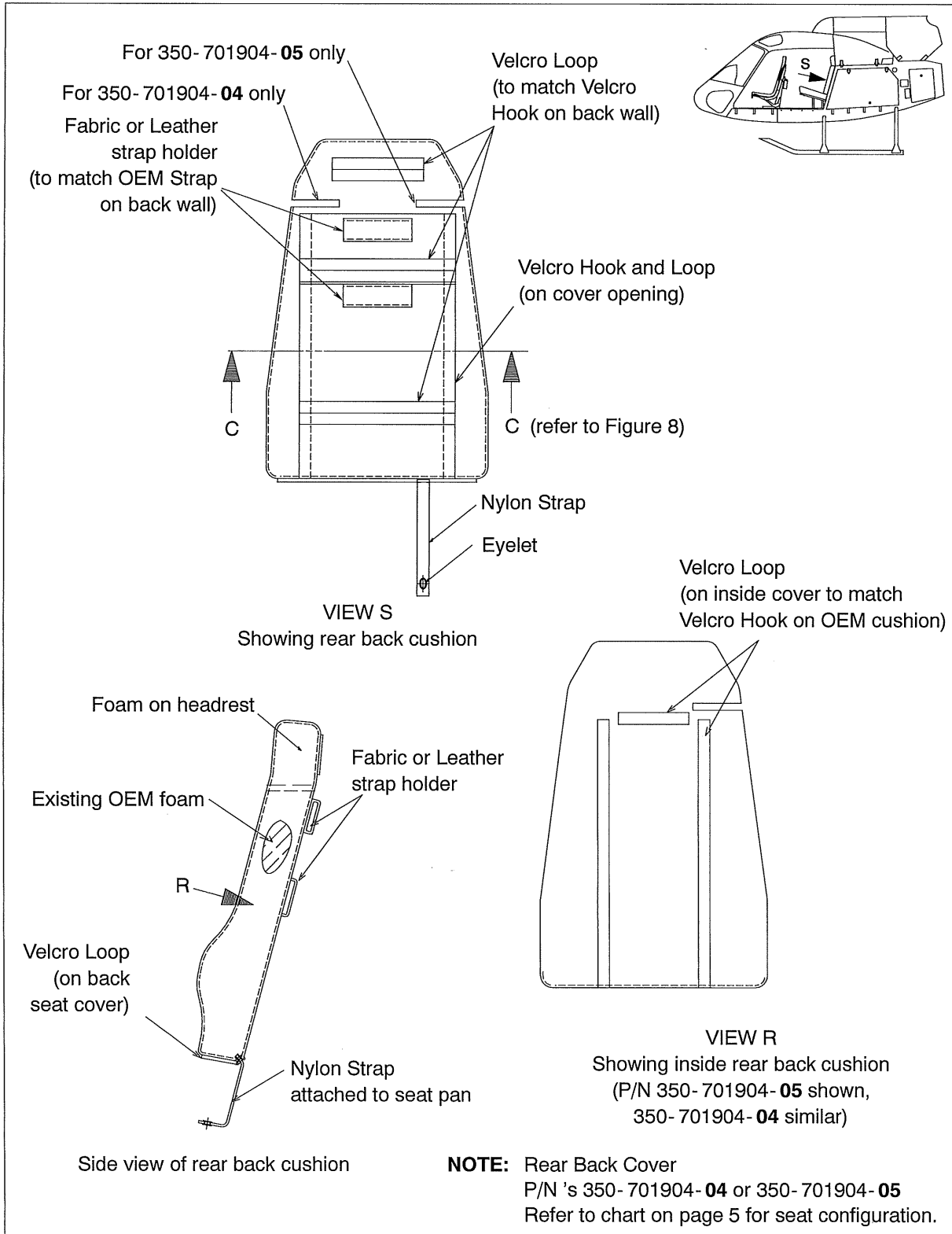

Figure 6 Rear Seat Cover Details for 350-701904-04 & -05

Transport Canada - Accepted

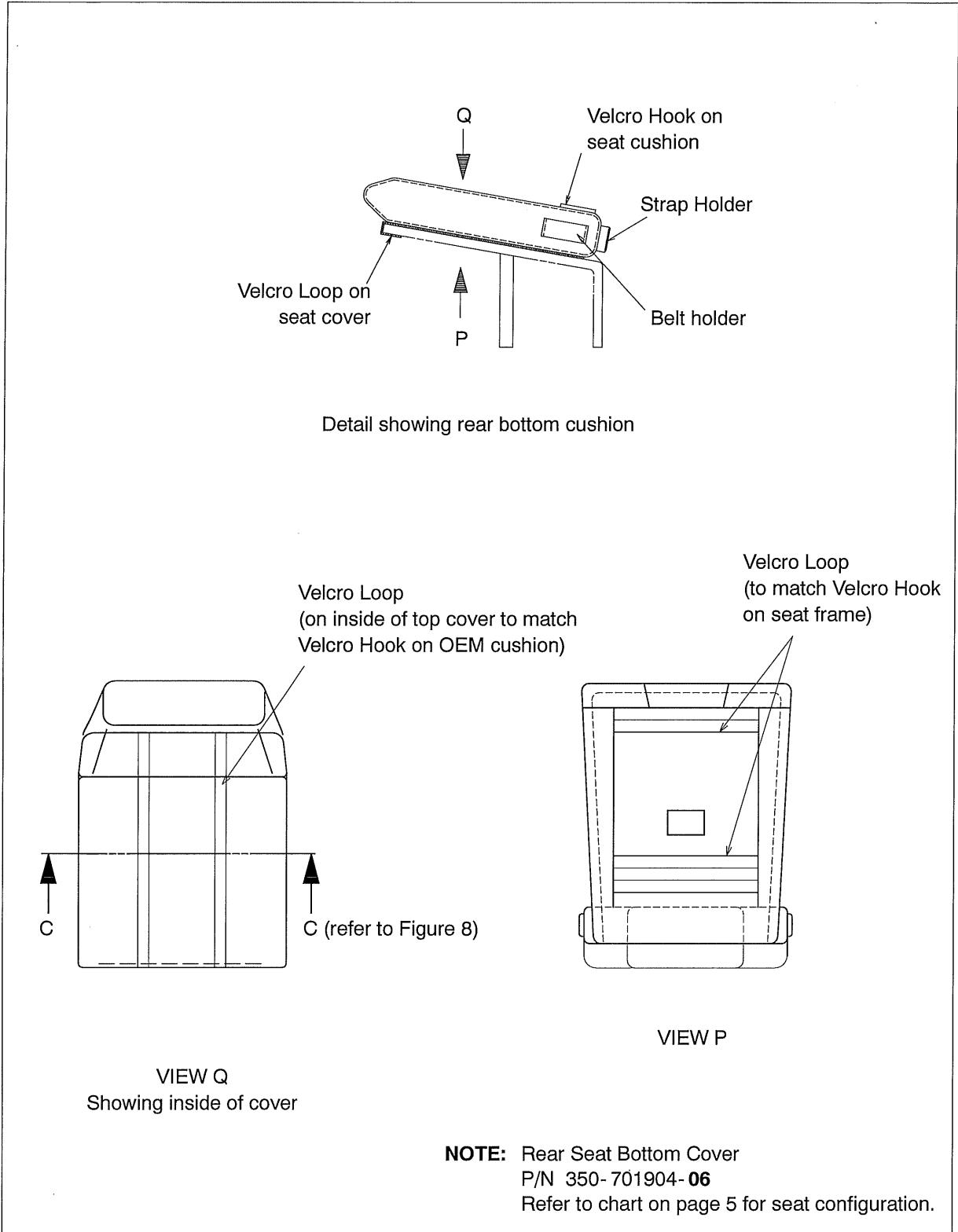

Figure 7 Rear Seat Cover Details for 350-701904-06

Transport Canada - Accepted

Legend (for Figure 8)

Item Description

1. Fabric or Leather Seat Cover
2. Perforated Leather (in mid section only)
3. Foam (as required)
4. Backing Cloth
5. T-Braid Seaming Cord

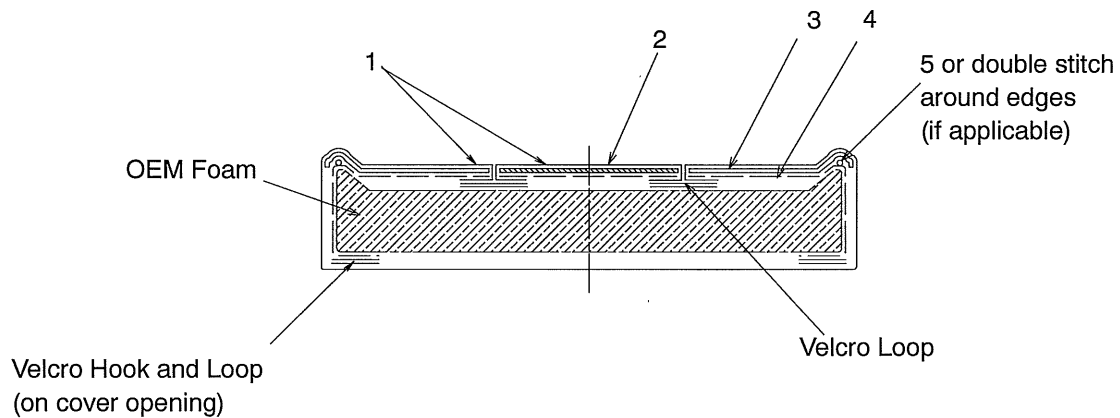

SECTION C- C
Showing rear back and bottom seat cover

Figure 8 Rear Seat Cover Details for 350-701904-06 (continued)

Transport Canada - Accepted

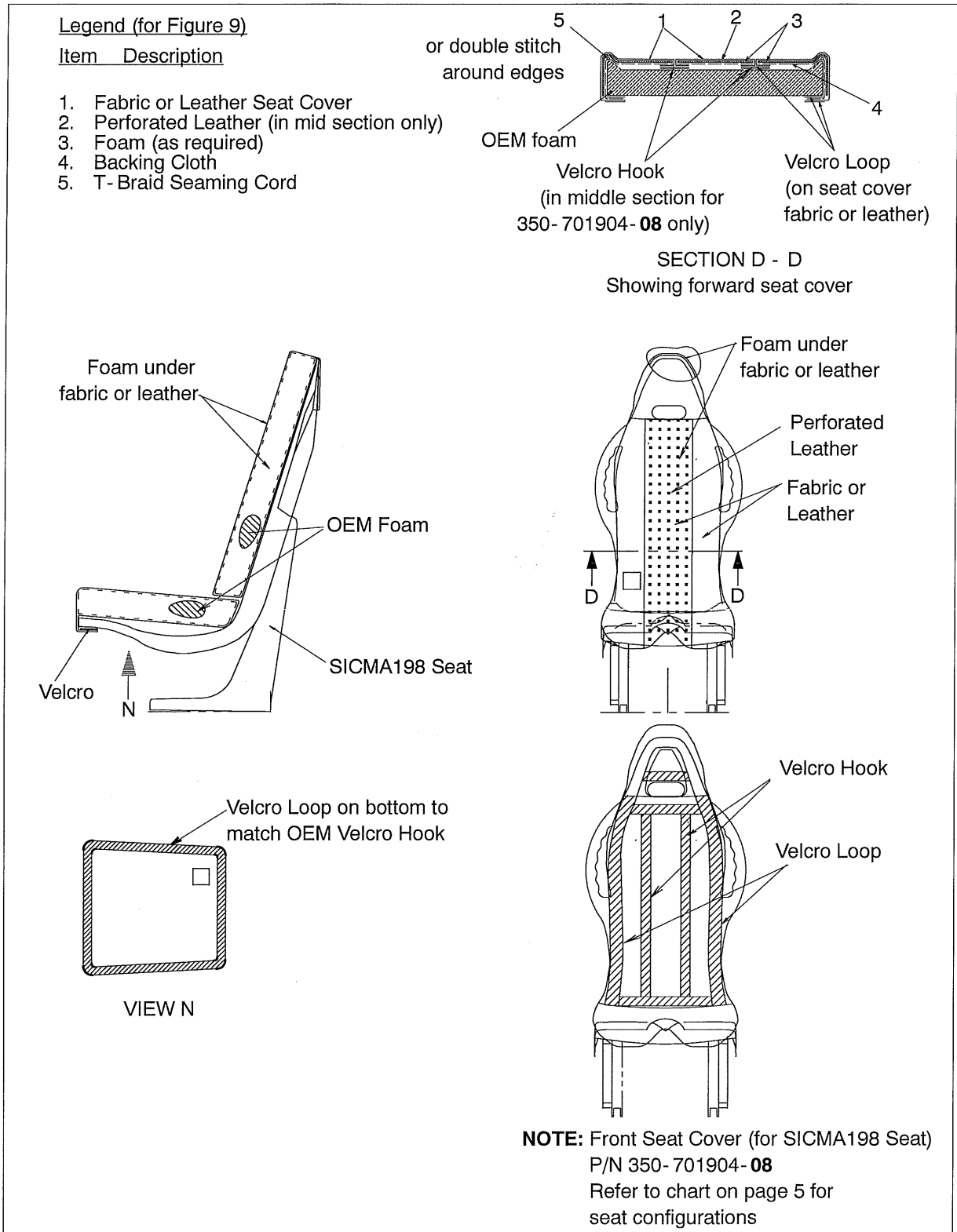

Figure 9 Forward Seat Cover Details for SICMA 198 Series Seat

Transport Canada - Accepted

AIRBUS HELICOPTERS CANADA LIMITED
C. REFERENCES

DOCUMENT	DOCUMENT TITLE
AMM (AS 350 B2/B3)	Aircraft Maintenance Manual
MET (AS 350 D, B, BA, B1 & AS 355)	Maintenance Manual
MTC (all aircraft)	Standard Practices Manual

D. ABBREVIATIONS & DEFINITIONS

ABBREVIATION	DEFINITION
Acc'd	Approved
AHCA	Airbus Helicopters Canada Limited
App'd	Approved
A/W	Airworthiness
CAR	Canadian Aviation Regulations
D	Days
DAPM	Design Approval Procedures Manual
FAA	Federal Aviation Administration
FH	Flight Hours
hrs.	hours
M	Months
OEM	Original Equipment Manufacturer
P/N	Part Number
ref.	reference
STC	Supplemental Type Certificate
TCCA	Transport Canada Civil Aviation

E. UNITS OF MEASUREMENT

ABBREVIATION / SYMBOL	UNIT OF MEASUREMENT
kg	kilogram
lb	pound
m	meter
mm	millimeters
in	inch
§§	Sections

Transport Canada - Accepted



AIRBUS HELICOPTERS CANADA LIMITED

**INSTRUCTIONS FOR CONTINUED
AIRWORTHINESS
STANDARD INTERIOR MODIFICATION
SEAT COVER
AS 350 / AS 355**

2. AIRWORTHINESS LIMITATIONS

The Airworthiness Limitations Section is approved by the Minister and specifies maintenance required by any applicable airworthiness or operating rule unless an alternative program has been approved by the Minister. ■

The Airworthiness Limitations Section is FAA approved and specifies inspections and other maintenance required under §§ 43.16 and 91.403 of the Federal Aviation Regulations unless an alternative program has been FAA approved. ■

The Airworthiness Limitations Section is approved and variations must also be approved.

No Airworthiness Limitations associated with this installation.

Transport Canada - Approved

AIRBUS HELICOPTERS CANADA LIMITED
3. CONTROL AND OPERATION

Control and operation of the aircraft remains unchanged.

4. INSPECTION SCHEDULE AND MAINTENANCE ACTION

NOTE: Use torque per MTC, Chapter 20-02-05-404, unless otherwise specified.

4.1. INSPECTION SCHEDULE

4.1.1. Every 150 FH or 12 M (Margins: 15 FH or 36 D) to coincide with the 150 FH or 12 M helicopter inspection, whichever occurs first:

ITEM	INSPECTION OR MAINTENANCE WORK	CORRECTIVE ACTION
A	- Check cushion security straps on back wall, shown in Figure 1, for: a. security	a. Secure as required.
B	- Visually inspect strap holder on the back of each rear seat, shown in Figures 4 and 6, for: a. separation	a. Check that strap is not separating from the seat cushion; If so, contact AHCA for replacement parts.
C	- Visually inspect the straps on the bottom of back rear seat, shown in Figures 4 and 6, for: a. separation	a. Check that straps are not separating from the seat cushions. If so, contact AHCA for replacement parts.
D	- Visually inspect snap buttons on forward seat cover, shown in Figures 2 and 3, for: a. security	a. Secure button snaps as required
E	- Check lumbar support, shown in Figure 2, for: a. tearing b. cleanliness	a. Check that foam/backing is not exposed. If so, contact AHCA. b. For cleaning instructions, refer to Appendix D.
F	- Check seat covers, item 1, shown in Figures 3, 5, 8 and 9 for a. tearing b. cleanliness	a. Check that foam/backing is not exposed. If so, contact AHCA. b. For cleaning instructions, refer to Appendix B for cleaning polyester fabric and Appendix C for cleaning leather.

Table 1 Inspection Schedule and Maintenance Action
 Every 150 FH or 12 M to coincide with the 150 FH or 12 M helicopter inspection, whichever occurs first
 (continued on following page)

Transport Canada - Accepted

AIRBUS HELICOPTERS CANADA LIMITED
4. INSPECTION SCHEDULE AND MAINTENANCE ACTION (continued)
4.1. INSPECTION SCHEDULE

4.1.1. Every 150 FH or 12 M (Margins: 15 FH or 36 D) to coincide with the 150 FH or 12 M helicopter inspection, whichever occurs first:

ITEM	INSPECTION OR MAINTENANCE WORK	CORRECTIVE ACTION
G	- Inspect eyelet on nylon straps under the rear seat pan, shown in Figures 4 and 6 for: a. damage	a. Check that eyelet has not been removed, shown on Figures 4 and 6. If so, contact AHCA.
H	- Visually inspect velcro hook and loop on lumbar support and on seat covers, shown in Figures 2 through 9, for: a. wear b. security	a. Wear is not permitted. If wear is evident, contact AHCA. b. Secure as required.

Table 1 Inspection Schedule and Maintenance Action
 Every 150 FH or 12 M to coincide with the 150 FH or 12 M helicopter inspection, whichever occurs first

5. REPLACEMENT COMPONENTS AND REPAIR / OVERHAUL INFORMATION

Contact AHCA for replacement component parts. No overhaul information required for this installation.

For replacement components contact:

 Airbus Helicopters Canada Limited
 1100 Gilmore Road, P.O. Box 250
 Fort Erie, Ontario L2A 5M9 Canada
 Telephone: (905) 871-7772

www.airbushelicopters.ca
6. TROUBLESHOOTING

There are no unique characteristics which require troubleshooting techniques.

7. SPECIAL TOOLING

No special test equipment or tools are required. Standard tools are adequate.

Transport Canada - Accepted

AIRBUS HELICOPTERS CANADA LIMITED

8. REMOVAL AND REPLACEMENT

PRELIMINARIES

- Remove standard seat covers and store.

A. REMOVAL

1) FWD SEAT COVER (Refer to Figures 2 or 9)

- a) Unsnap cushions from seat frame, as applicable.
- b) Remove cushions from pilot and co-pilot seat frame and place on workbench with back of the cushion facing up.
- c) Carefully peel open the velcro hook and loop. Remove the cushion cover from the OEM foam.

2) REAR BACK AND BOTTOM SEAT COVERS (Refer to Figures 4 and 6)

NOTE: For newer style OEM passenger seat cushions, the headrest is not separate.

- a) Remove security straps from fastener on bottom of seat pan.
- b) Remove cushion security straps from the vinyl strap holders located on the back of the seat back cushions.
- c) Remove seat back cushions and seat bottom cushions from the rear seat frames. Place cushions on a clean workbench with underside facing up. Remove the headrest.
- d) Carefully peel open the velcro hook and loop. Remove the cushion cover from the OEM foam.

AIRBUS HELICOPTERS CANADA LIMITED

8. **REMOVAL AND REPLACEMENT** (continued)

B. REPLACEMENT

1) **FWD SEAT COVER** (Refer to Figures 2 or 9)

- a) Open out seat cover on a flat surface.
- b) Align inside of cover with a plastic sheet, enough to cover the velcro.
- c) Place OEM cushion into cover and once fitted into place, quickly remove the plastic sheet. Press velcro hook and loop until secure.
- d) Reposition seat cushion onto forward seat frame and secure using velcro hook and loop and snaps.

2) **REAR BACK AND BOTTOM SEAT COVERS** (Refer to Figures 4 and 6)

BOTTOM CUSHION

- a) Open flap on back of bottom cushion and insert OEM foam.
- b) Align velcro hook on OEM foam with velcro loop inside cushion cover and secure.

BACK CUSHION

- a) Open out seat cover on a flat surface (Figure 6 only).
- b) Open flap on back of bottom cushion and insert OEM foam (Refer to Figure 4 only).
- c) Align velcro hook on OEM foam with velcro loop inside cushion cover and secure.
- d) Close cover opening and secure using velcro hook and loop.
- e) Reposition rear seat cushions into aircraft. Feed OEM cushion security straps through both strap holders located on the back of the back cushion to secure the back cushion to the cabin wall. Align velcro loop on cushion cover with velcro hook on cabin back wall and seat frame. Align rear seat cushions into aircraft aligning velcro loop on cover with velcro hook on seat frame. Secure back and bottom cushions together with velcro hook and loop.
- f) Bring nylon straps through strap holders on bottom cushion and secure to fasteners under the seat pan using eyelets (4 places).

HEADREST (original style seat covers only)

- a) Open cover and insert OEM foam.
- b) Secure using velcro hook and loop.

NOTE: If using headrest, secure headrest to top of back cushions using Velcro.

AIRBUS HELICOPTERS CANADA LIMITED
9. WEIGHT AND BALANCE DATA
A. Removed Items - OEM Seat Covers

DESCRIPTION	WEIGHT		ARM		MOMENT	
	kg	lbs	m	in	kg m	lb in
Standard Forward Seat Covers	- 1.40	- 3.1	1.57	61.8	- 2.20	- 191.6
Standard Rear Seat Covers	- 4.20	- 9.3	2.50	98.4	- 10.50	- 915.1
Total	- 5.60	- 12.4	2.27	89.3	- 12.70	- 1106.7

B. Added Items - Fabric Seat Covers

DESCRIPTION	WEIGHT		ARM		MOMENT	
	kg	lbs	m	in	kg m	lb in
Forward Seat Covers (350-701904-01 or 350-701904-03)	2.35	5.2	1.57	61.8	3.69	321.4
Rear Seat Covers (350-701904-02)	5.55	12.2	2.50	98.4	13.88	1200.5
Total	7.90	17.4	2.22	87.5	17.56	1521.8

C. Added items - Leather Seat Covers

DESCRIPTION	WEIGHT		ARM		MOMENT	
	kg	lbs	m	in	kg m	lb in
Forward Seat Covers (350-701904-01 or 350-701904-03)	2.65	5.8	1.57	61.8	4.16	358.4
Rear Seat Covers (350-701904-02)	6.00	13.2	2.50	98.4	15.00	1298.9
Total	8.65	19.0	2.22	87.2	19.16	1657.3

Transport Canada - Accepted

AIRBUS HELICOPTERS CANADA LIMITED

9. **WEIGHT AND BALANCE DATA** (continued)

D. Added Items - Fabric Seat Covers

DESCRIPTION	WEIGHT		ARM		MOMENT	
	kg	lbs	m	in	kg m	lb in
Forward Seat Covers (350-701904-01, 350-701904-03 or 350-701904-08)	2.35	5.2	1.57	61.8	3.69	321.4
Rear Seat Covers (350-701304-02 or 350-701904-04, 350-701904-05 and 350-701904-06)	5.55	12.2	2.50	98.4	13.88	1200.5
Total	7.90	17.4	2.22	87.5	17.56	1521.8

E. Added Items - Leather Seat Covers

DESCRIPTION	WEIGHT		ARM		MOMENT	
	kg	lbs	m	in	kg m	lb in
Forward Seat Covers (350-701904-01, 350-701904-03 or 350-701904-08)	2.65	5.8	1.57	61.8	4.16	358.4
Rear Seat Covers (350-701304-02 or 350-701904-04, 350-701904-05 and 350-701904-06)	6.00	13.2	2.50	98.4	15.00	1298.9
Total	8.65	19.0	2.22	87.2	19.16	1657.3

10. **PLACARDS AND MARKINGS**

There are no placards or markings associated with this modification.



Transport Canada - Accepted

Deleted

Deleted

TECHNICAL INFORMATION

ODYSSEY, CREPE FR, SEGMENT

Pattern 54"	Content and Backing	Weight/ Linear Yd	Pattern Repeat	Finish	Abrasion Wyzenbeek 	Light Fastness 	Cleaning Code
CREPE FR	50% FR Polyester, 50% Polyester	14 oz.	None	None	Exceeds 207,000 Double Rubs	Exceeds 60 hours	W
ODYSSEY <i>Directional</i>	64% Avora Polyester, 36% Polyester Environmentally Friendly FR Backing	14 oz.	.875" H .75" V	None	Exceeds 60,000 Double Rubs	Exceeds 40 hours	WS
SEGMENT <i>Directional</i>	66% FR Avora, 18% Polyester, 16% FR Olefin Latex Backing	15 oz.	4.625" H 3.5" V Random Matching	Stain Repellent	Exceeds 213,000 Double Rubs	Exceeds 40 hours	WS

FLAMMABILITY

Treated to pass FAR25.853(a) Amdt 25-116 Appendix F Part I (a)(1)(II)

California Technical Bulletin #117, Section E is equivalent to BIFMA and NFPA 260 is equivalent to UFAC Class 1.

May comply with California Technical Bulletin 133 when combined with appropriate components.

CLEANING INFORMATION

W: Water-Based Cleaner- Spot clean, using the foam only for a water-based cleaning agent such as a mild detergent or non-solvent upholstery shampoo product. Apply foam with a soft brush in a circular motion. Pretest a small area before processing. Do not use alcohol-based cleaners.

WS: Water-Solvent Cleaner- Spot clean, with mild solvent, an upholstery shampoo, or the foam from mild detergent. When using a solvent or dry cleaning product, follow instructions carefully and clean only in a well-ventilated room. Avoid any product that contains tetrachloride or other toxic materials. With either method, pretest a small area before proceeding.

CUSTOM CAPABILITIES

For information or assistance with products or services, call us at 949-540-2650 or refer to our web site www.marionaircraft.com.

Patterns in the Marion line can be custom colored.

Please keep this card intact. Individual samples available.

Color matching: Marion will always attempt to ship a satisfactory commercial match. Because of industry standard dye lot variation, colors may not match exactly.

* ACT* Registered Certification Marks



A Division of Hansair Group
20312 HERMANA CIRCLE LAKE FOREST, CA 92630 USA

TEL: 949-540-2650 FAX: 949-540-2652

EMAIL: INFO@MARIONAIRCRAFT.COM WWW.MARIONAIRCRAFT.COM



Leather

Recommended General Maintenance

We are often asked, "Is leather practical?" The answer to this depends on your definition of practical. If we expect leather to be "plastic perfect" and never show use or develop a patina, it might not be practical. But if we understand and appreciate the changing beauty of fine, natural leather and its amazing durability, it is most practical.

Leather is resilient. It will outwear textiles many times over. Since fabrics are woven, any change in their appearance from age and use detracts from their beauty. Leather, on the other hand, adjusts to its environment. It mellows gracefully with age. Leather is expected to change; even the oils from our hands help to develop the patina.

Full grain leather is not demanding and requires very little care. It should not be abused by harsh cleaners or substances such as wax or mink oils, saddle soap or other leather polishes. These become surface sealants which keep premium full grain leathers from breathing (hence they will eventually dry out and crack). A periodic wipe with a cool damp cloth is sufficient means of cleaning under normal conditions.

The following guidelines will help you to maintain the beauty of Spinneybeck leather without destroying any of the natural characteristics:

Finished Leather: Acqua, Alaska, Amazon, Andes, Antique, Derby, Ducale, España, Forte, Hand Tipped, Leather Tiles, Lucente, Portofino, Sabrina, Salon, Velluto Pelle, Volo

Finished leather, the most popular, is smooth and has a satiny finish. Its breathable protective finish makes it most suitable for high traffic areas or contract use. It is maintained by wiping with a cool, damp cloth. For tougher soiling, use a pH balanced soap on a cloth and rinse. Remember to always use cool water. Repeat if needed.

Naked Leather: Arizona,* Belting Leather,* Capri,* Copenhagen,* Cordovan,* Distressed,* Prima, Riva, Saddle

Naked leathers have no surface or impregnated finish, other than dye matter, which may mask or alter the natural state of the leather. There is no barrier against spillage or staining, therefore, naked leather should be selected with this in mind.

The only recommended cleaning method for a naked leather is to wipe the entire surface with a soft cloth and cool water. Do not spot rub, for it will darken only that area. The idea is to even out any abrasions or stains.

** Leathers noted should be cleaned as a naked leather due to their very light application of finish.*

Grain Sueded Leather: Ducale Velour, Marissa

Full grain leathers that have been lightly buffed to raise the nap of the surface are referred to as "grain sueded" leathers. This produces the softest hand of any suede leathers. For maximum soil resistance and durability these leathers have received an impregnated soil resistant treatment.

Grain sueded leather can be maintained with reasonable care as spillage will bead up and roll off. However, it should not be allowed to puddle, but be blotted up immediately. For normal care, grain sueded leather should be dry brushed occasionally. Remove general soilage with a suede cleaning block.

Textured Sueded Leather: Maremma

Textured Sueded Leather is an aniline dyed leather with a dense sueded surface. The textured surface is protected by an impregnated, soil resistant treatment which shields the surface without disturbing the suppleness and rich coloration.

Textured sueded leather can be maintained with reasonable care as liquids will bead allowing spillage to be blotted up immediately. For normal care, the surface of textured suedes should be brushed occasionally with a scotch brite pad followed by vacuuming to remove dirt and loose fibers.

Note: Certain inks or stains cannot be removed from leather just as they cannot be removed from other upholstery fabrics. Use caution to avoid these accidents. Remember that our leathers are all natural "skins." Treat your leather the same way you would treat your own skin.

Please call for more information about Spinneybeck Maintenance Kits, which include our specially formulated cleaners, conditioners and ink removers.

Updated: May 2008

Spinneybeck • 425 CrossPoint Parkway • Suite 100 • Getzville, New York 14068
(800) 482-7777 / (716) 446-2380 / (716) 446-2396 Fax

Spinneybeck Ireland • Suite 2, Morrison Chambers • 32 Nassau Street • Dublin 2, Ireland

Tel. +353 1 6729192 / Fax +353 1 6336506

www.spinneybeck.com



Nomex

NOMEX

ARAMID FIBER

LAUNDERING GUIDE

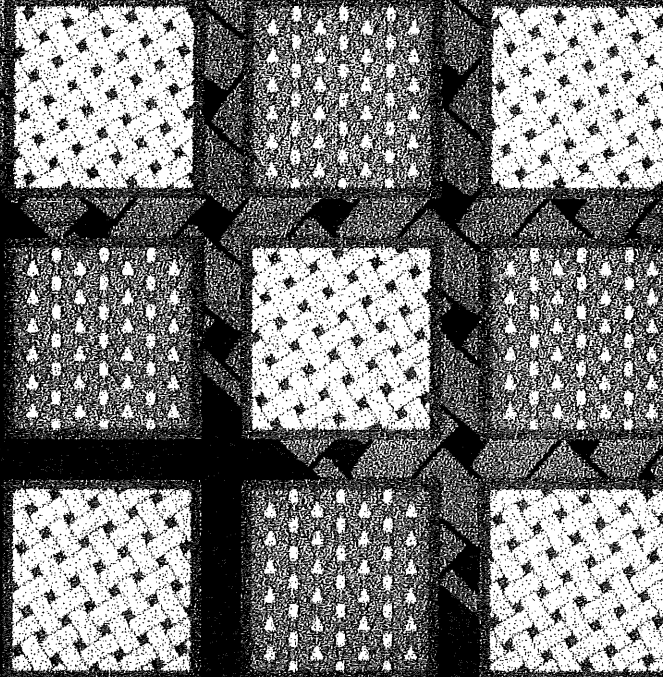

TABLE OF CONTENTS

SECTION I: INTRODUCTION TO NOMEX® ARAMID FIBER

<i>General Information</i>	I-5
----------------------------	-----

SECTION II: COMMERCIAL LAUNDERING GARMENTS OF NOMEX® ARAMID FIBER

<i>Sorting and Wash Wheel Loading</i>	II-6
<i>Washing Supplies</i>	II-6
<i>Detergent</i>	II-6
<i>Alkalinity (pH)</i>	II-6
<i>Bleach</i>	II-6
<i>Sour</i>	II-6
<i>Softeners, Anti-Stats and Wicking Agents</i>	II-6
<i>Non-Durable Water and Oil Repellents</i>	II-7
<i>Washing Procedures</i>	II-7
<i>General Wash Formulas</i>	II-7
<i>Wash Temperatures</i>	II-7
<i>Prevention of Soil Redeposition</i>	II-7
<i>Rinsing</i>	II-7
<i>Souring</i>	II-8
<i>Softeners, Anti-Stats and Wicking Agents</i>	II-8
<i>Repellents</i>	II-9
<i>Drying and Finishing</i>	II-9
<i>General Guidelines</i>	II-9
<i>Tumble Dry Conditioning/Finishing</i>	II-10
<i>Wet-to-Dry Type Tunnel Drying/Finishing</i>	II-10
<i>Dry-to-Dry Type Tunnel Drying/Finishing</i>	II-10
<i>Pressing</i>	II-10

SECTION III: HOME LAUNDERING GARMENTS OF NOMEX® ARAMID FIBER

<i>General Guidelines</i>	III-11
<i>Sorting</i>	III-11
<i>Pretreating</i>	III-11
<i>Preparing the Wash Load</i>	III-11
<i>Load Size</i>	III-11
<i>Wash Water Temperature</i>	III-11
<i>Detergents</i>	III-11
<i>Water and Water Conditioners</i>	III-11
<i>Bleaches</i>	III-12
<i>Fabric Softeners and Anti-Stats</i>	III-12
<i>Tumble Drying</i>	III-12
<i>Ironing</i>	III-12

SECTION IV: DRY CLEANING GARMENTS OF NOMEX® ARAMID FIBER*General Guidelines*

IV-13

SECTION V: REMOVING SPOTS AND OTHER NON-STANDARD CONTAMINANTS FROM GARMENTS OF NOMEX® ARAMID FIBER*General Guidelines*

V-14

SECTION VI: APPENDICES

<i>Appendix I</i>	<i>Source List for Laundering Products</i>	<i>VI-15</i>
<i>Appendix II</i>	<i>Suggested Wash Procedure for Lightly Soiled Garments of NOMEX® Aramid Fiber</i>	<i>VI-16</i>
<i>Appendix III</i>	<i>Suggested Wash Procedure for Heavily Soiled Garments of NOMEX® Aramid Fiber</i>	<i>VI-17</i>
<i>Appendix IV</i>	<i>Application of AVITEX® DN Softener/Anti-Stat</i>	<i>VI-18</i>
<i>Appendix V</i>	<i>Softener/Anti-Stat Additions Chart</i>	<i>VI-20</i>
<i>Appendix VI</i>	<i>Exhaustion Procedure for ZONYL® 6991 Application</i>	<i>VI-21</i>

SECTION I: INTRODUCTION TO NOMEX® ARAMID FIBER

GENERAL INFORMATION

Garments of NOMEX® aramid fiber have been used for more than 30 years for protection against fire-related personal injury. During this time, the line of NOMEX® products has been expanded and improved to include products made from fiber blends, such as blends of NOMEX® with KEVLAR® and static-dissipative fibers. The family of NOMEX® aramid fibers now includes:

- 100% NOMEX® T-450, which is used in its natural, undyed state or dyed for sewing thread;
- NOMEX® III, a blend of NOMEX® and KEVLAR®;
- NOMEX® IIIA, a blend of NOMEX®, KEVLAR® and a static-dissipative fiber; and
- Producer-colored NOMEX®, which is supplied in a blend with KEVLAR® and may also be supplied with a static-dissipative fiber.

The introduction of new, low-temperature detergent formulations has resulted in improved washfastness for garments of NOMEX®. Accordingly, DuPont has modified its recommended procedures for laundering garments of NOMEX®. The revised procedures outlined in this bulletin are designed to remove flammable contaminants and maximize garment life.

Properly dyed and finished garments of NOMEX® are inherently flame resistant. No laundry procedures are known to remove the flame resistance of NOMEX®. However, thermal protection *can* be compromised by the presence of flammable contaminants on the garment, or on the fabric from which it is made. Even though garments of NOMEX® are inherently flame resistant, flammable contaminants on the garments can ignite and burn until consumed, thus increasing heat transfer to the wearer.

Laboratory tests have shown that the procedures recommended in this bulletin are effective in removing oil-based soils from garments while minimizing the impact on colorfastness and wear life. Users of textile items made of NOMEX® should ensure that the techniques they use achieve similar results.

This bulletin is intended to provide general recommendations on conditions and products for laundering garments of NOMEX®. Throughout the remainder of this bulletin, all variations of NOMEX® and blends of NOMEX® will be referred to as NOMEX®. The products and conditions described in this bulletin performed well in laboratory evaluations; other conditions and products may provide equivalent results. To achieve the best results for specific applications, assistance should be obtained from chemical suppliers for the chemicals used.

SECTION II: COMMERCIAL LAUNDERING

GARMENTS OF NOMEX® ARAMID FIBER

SORTING AND WASH WHEEL LOADING

Garments of NOMEX® should be washed separately from other articles to avoid contamination with lint of flammable fibers. In addition, to avoid possible staining of light-colored garments, dark-dyed garments of NOMEX® should be sorted and washed separately from very light shades or undyed articles.

To ensure thorough cleaning, washer loads for garments of NOMEX® should be approximately $\frac{1}{3}$ the weight of loads recommended by the wash wheel manufacturer for 100% cotton goods. However, because garments of NOMEX® generally weigh less than their all-cotton counterparts, no significant loss in the number of garments processed per wash cycle should be experienced.

WASHING SUPPLIES

A source list for laundering products is presented in Appendix I. Laboratory tests have shown these products to be effective; other products also may provide acceptable results.

Detergent

Many commercial and industrial detergent formulations have been evaluated in the laboratory for their cleaning effectiveness and impact on washfastness. Tests show that formulations designed for use at a temperature of 140°F (60°C) or less — such as high-surfactant, low-alkalinity products — adequately clean NOMEX® and provide the best fabric color retention. Color loss after 200 launderings in a commercial wash wheel using these formulations has been found to be minimal. The use of soaps for laundering NOMEX® is not recommended due to the potential formation of insoluble scums with hard water. Soap scums may be flammable and could adversely affect the thermal protective performance of the garment.

Alkalinity (pH)

The detergents listed in Appendix I have pH values ranging from 9 to 11 and have been found to effectively lift dirt and oil from the NOMEX® fiber. The use of higher wash temperatures and detergent formulations with higher alkalinity will improve cleaning; however, these harsher conditions can negatively impact the colorfastness of the garments. Users must choose appropriate laundering conditions to maintain the desired balance between garment cleanliness and color retention.

Bleach

Only oxygen-based bleach is recommended for use on garments of NOMEX® — *chlorine bleach should not be used*. Although chlorine bleach will not affect the inherent flame resistance of NOMEX®, it may cause strength and color loss in garments over time.

Sour

When laundering items of NOMEX®, the use of a sour after thorough rinsing helps ensure that any remaining traces of alkalinity are neutralized.

Softeners, Anti-Stats and Wicking Agents

The following wash wheel supplies perform useful and often highly desirable functions when applied to the load in the last operation:

- *Fabric softeners** impart a softer "hand" to the fabric and assist in wrinkle removal when articles of NOMEX® are tunnel or tumble dried.
- *Anti-stats** reduce the effects of nuisance static electricity, such as clinging and lint pick-up. Nuisance static is fairly common with textiles, especially in low-humidity environments. Under normal conditions, garments of NOMEX® IIIA do not require the use of anti-stats because NOMEX® IIIA contains a proprietary static-dissipative fiber.

*Some materials when added to garments may have a negative impact on thermal protection. The impact of fabric softeners, wicking agents and anti-stats should be evaluated at the intended use level prior to routine use.

NOTE: Although certain anti-stats can provide a high degree of static control when properly applied in the wash wheel, they cannot ensure safety in situations where a discharge of static electricity could create a hazard to life or property, such as in an explosive or highly flammable environment. For this reason, it is important that personnel and equipment be properly grounded for maximum safety.

- *Wicking agents** help fabrics adsorb and spread moisture. Experience suggests that these characteristics contribute to comfort in warm, humid environments by helping to rapidly dissipate perspiration, thereby taking full advantage of the cooling effect of evaporation.

Non-Durable Water and Oil Repellents

Water and oil repellency may be a desirable feature in some industrial applications. If the original fabric has not been treated with a repellent, water and oil repellency can be obtained by using sprays or laundry-applied chemicals. Laboratory tests have shown that fluorocarbon sprays, such as Winsol® Fireline Water Repellent, and laundry additives, such as ZONYL® 6991, when applied according to manufacturers' recommendations, will impart water and oil repellency to garments of NOMEX® with minimal effect on the thermal protection of the garment. These materials will cause liquids to bead on the fabric surface and minimize wicking into the fabric. They will not, however, prevent liquids from being forced through the open structure of the fabric.

For example, ZONYL® 6991 may be applied in conjunction with AVITEX® DN without reducing its anti-static activity. However, the wicking action of the AVITEX® DN will be compromised due to the repellency imparted by the ZONYL® 6991. The use of these or other chemicals should be evaluated with respect to the particular oils and/or solvents encountered to determine if they meet the required chemical and thermal protective performance criteria. In addition, because these water repellents may wear away or wash out, re-treatment may be necessary, especially after garment cleaning.

*Some materials when added to garments may have a negative impact on thermal protection. The impact of fabric softeners, wicking agents and anti-stats should be evaluated at the intended use level prior to routine use.

WASHING PROCEDURES

General Wash Formulas

The formulas in Appendices II and III have been developed to wash garments of NOMEX®. Within the limits of these general procedures, modifications should be made to meet the needs of particular types of wash loads and other specific quality standards. To achieve desired results, assistance should be obtained from chemical suppliers.

Wash Temperatures

The detergents listed in this bulletin are primarily designed to work at 140°F (60°C). At this temperature, these surfactant-based formulas effectively lift oily soil while maximizing color retention. For heavily stained and oily garments of NOMEX®, a higher temperature wash formula may be required for adequate cleaning. The use of higher temperature formulas will not affect the inherent flame resistance of the garments or their overall wear life. However, higher wash temperatures or alkalinity levels may adversely affect garment colorfastness. Where color loss is a concern, dry cleaning is an alternative method of removing heavy soil and may be preferable to repeated high-temperature washing.

Prevention of Soil Redeposition

To improve soil removal and minimize soil redeposition in heavily soiled loads, a "multiple add" procedure is recommended. Adding washing supplies to the suds cycle ensures that the concentration is kept high enough to keep the soil in suspension.

Rinsing

Garments of NOMEX® must be adequately rinsed to remove residual wash chemicals. Rinse cycles should be continued until the pH of the rinse closely approaches that of the water supply. To minimize washer-induced wrinkles, water temperature should be reduced in each succeeding rinse cycle until the last operation (sour), where it should be 90°F (32°C) or lower.

Souring

Residual alkalinity in garments of NOMEX® can cause skin irritation and other problems. To ensure that all traces of wash chemical alkalinity are neutralized, sour can be added to the final rinse cycle in the wash wheel. Garments should not be rinsed further after the sour is added. Overuse of sour should be avoided because it will result in highly acidic fabrics. Any standard or buffered sour is acceptable for use with garments of NOMEX®.

Softeners, Anti-Stats and Wicking Agents

Generally, softeners and anti-stats are not permanently affixed to fabrics. Instead, they should be applied in the last wash wheel operation, then reapplied at the end of each subsequent wash cycle. Most are compatible with sour and can be applied in the sour bath. When applying any proprietary laundry product in the wash wheel, it is essential to seek the supplier's advice on its exact use and possible effect on the flammability and thermal protection of the garment.

Although the use of anti-stats may not be required with garments of NOMEX® IIIA, the "feel" and wickability of such garments can be improved with softeners and wicking agents. For example, tests have shown that AVITEX® DN softens fabrics of NOMEX®, reduces static propensity and significantly improves wicking, without adversely affecting thermal protection.

When using AVITEX® DN, the following should be noted (see Appendices II and III):

- AVITEX® DN does not permanently attach itself to the NOMEX® fiber; therefore, it must be reapplied or "added on" at the end of each wash cycle.
- AVITEX® DN is compatible with sour and can be conveniently applied during the souring step.
- AVITEX® DN tends to foam profusely. To control this foaming action, a very small amount of an effective anti-foam agent can be applied to the bath.
- As with sour, garments should not be rinsed after AVITEX® DN is applied.
- When applying AVITEX® DN, the cycle time should be extended to ensure complete and uniform distribution on the garments.

- Within the limits recommended, AVITEX® DN does not adversely affect the thermal protective performance of garments of NOMEX®.
- The "add-on" of AVITEX® DN is a function of both the concentration in the final cycle and the percentage of "wet pickup" (the moisture retained after the final cycle and extraction).
- AVITEX® DN add-on can be improved by raising the concentration in the final rinse and/or increasing the percentage of wet pickup.
- The amount of AVITEX® DN added to the wheel should not be reduced for partial loads. Always add AVITEX® DN in the amount calculated for a full load, unless the water level in the final bath cycle has been reduced.
- Contamination of the AVITEX® DN supply by detergents should be avoided because it can destroy the anti-static property. Keep the supply container closed to avoid evaporation and drying out. Gelling or thickening of the AVITEX® DN indicates product alteration or deterioration. In such cases, the supply should be replaced.

CAUTION: When using AVITEX® DN, avoid contact with the eyes or skin. In the event of contact with the eyes, flush the eyes thoroughly with water for at least 15 minutes and consult a physician. In the event of skin contact, wash thoroughly with soap and water. For detailed use instructions, consult the DuPont Material Safety Data Sheet for AVITEX® DN.

Effective softening, static suppression and wicking are achieved with garments of NOMEX® when AVITEX® DN is applied, as recommended, to give a calculated 0.50% to 0.75% add-on, based on the dry weight of the garment. Achieving the desired add-on depends on a number of factors that vary with different laundry procedures. Appendix IV provides definitions of the essential terms employed and gives two examples of how to calculate the amount of AVITEX® DN softener necessary to achieve the desired add-on. Appendix V contains a chart that can be used when the percentages of wet pickup and wheel volumes are known.

AVITEX® DN tends to cause foaming, which may overrun the wash wheel. Excessive foaming reduces agitation and will retard or prevent the uniform distribution of the softener/anti-stat in the wheel. If foaming is excessive, it can be controlled by adding approximately 0.005% of Dow Corning® Antifoam 1430 to the wheel when the softener/anti-stat is added. This level of antifoam is equivalent to approximately 0.67 oz/100 gal. (5 g/100 L) of liquid in the wash wheel. Silicone anti-foams can result in water treatment problems because they are not easily biodegradable. Check manufacturers' recommendations before using these products.

Repellents

Some fabrics are treated with water repellents during the manufacturing operation prior to the fabrication of garments. These treatments may last for many cleanings, but are not considered permanent. Other repellents are available that can be applied during or after laundering to previously untreated garments, or to previously treated garments that have lost their repellency. Repellent applications will reduce moisture wicking and can make garments that come in contact with the body less comfortable in hot, humid weather. In addition, repellent chemicals may be flammable. Before applying any repellent, it should be evaluated to determine if it will impact the thermal protective performance of the garment.

Repellents can reduce the penetration of oils, solvents and water through the fabric by causing them to bead up on the fabric surface. The level of repellency depends on the type and level of the material being applied, as well as the characteristics of the soils coming into contact with the garment. Fabrics used in industrial work or laboratory garments are not designed to be chemical or liquid barriers. Thus, where exposure to hazardous materials must be prevented, an appropriate chemical barrier suit must be worn.

Winsol® Fireline Water Repellent is available as an aerosol spray or in bulk form. It is an example of a repellent that can be sprayed onto the surface of a clean, dry garment. It must be applied in a well-ventilated area, and the solvent must be allowed to evaporate before garment use. This material will wash out com-

pletely after several launderings and must be reapplied to maintain repellency. The amount applied should be the minimum required to obtain the desired repellency. Repellency can be determined by applying a drop of liquid (water, oil or solvent) to the fabric surface to determine whether it wicks into the fabric or beads on the surface. Not all liquids will be repelled. Contact the manufacturer for applicability and impact on fabric flammability.

Another repellent, ZONYL® 6991, is applied in the final wash wheel rinse and is exhausted onto the fabric by adjusting the pH and increasing the water temperature. Garments must be hot-air dried after application for this repellent to be effective. Under the conditions shown in Appendix VI, approximately 80% of the material added to the final rinse will be exhausted onto the garments. An initial level of 2% to 3% on the dry weight of the garment is required for noticeable repellency of water or motor oil. ZONYL® 6991 may or may not be removed during the cleaning process, depending on the procedures used. Additional repellent should not be added during subsequent cleaning cycles unless indicated by a repellency test. Buildup or application of excessive levels of repellents can increase the level of flammable material and compromise the thermal protective performance of the garment. Use for specific applications should be evaluated prior to general adoption.

If AVITEX® DN is normally used for static control, it should be added with ZONYL® 6991 in the final rinse. If AVITEX® DN is added earlier in the wash procedure, it can be removed during further rinsing. The same holds true for ZONYL® 6991.

DRYING AND FINISHING

General Guidelines

Garments of NOMEX® can be rapidly dried and finished with good appearance using several methods. Economic savings are possible if drying and finishing are combined into one step, as with the wet-to-dry tunnel method.

No matter which method is chosen, every effort should be made to avoid introducing hard-set and unnecessary wrinkles during washing or extraction. For best results,

garments should not be bagged. However, if bagging is necessary, the bags should not be filled to more than half their capacity to ensure that the garments have adequate freedom of movement. Similarly, the wash wheel should not be overloaded. After the break and suds cycles, the water temperature should gradually be reduced through several rinse cycles to avoid introducing "thermal shock" wrinkles, which can be very difficult to remove. The final operation (sour) should be carried out at a temperature of 90°F (32°C) or lower.

Garments should not be fully extracted unless they are to be pressed. If an extraction is used as a preliminary step to other finishing methods, garments should be cold and subjected only to very brief and light hydraulic or centrifugal pressure. Extraction will reduce softener add-on by diminishing water carry-over; thus, a higher softener concentration in the final rinse will be required to achieve the desired add-on.

Tumble Dry Conditioning/Finishing

In some instances, tumble dry conditioning is the only finishing necessary for garments of NOMEX®. Tumble dry conditioning also can be done prior to dry-to-dry tunnel finishing or pressing. Adequate tumbling action is necessary for good wrinkle removal; therefore, tumble dryers should not be overloaded. Garments will dry rapidly and satisfactorily at exhaust air temperatures between 140°F (60°C) and 160°F (71°C). Garment temperature measured in the basket should not exceed 280°F (138°C). Excessive shrinkage and color loss can occur if higher temperatures are encountered. Tumbling without heat for an additional 10 minutes at the end of the drying cycle will cool the garments and help avoid dryer-induced wrinkles. To avoid set-in wrinkles, garments should not remain in a hot tumbler when it is not in motion, nor should they be folded or stacked.

Wet-to-Dry Type Tunnel Drying/Finishing

With this method, wet garments from the wash wheel are hung on hangers, placed on a conveyor and passed through a tunnel containing forced air supplied at 300°F (149°C) dry bulb and 190°F (88°C) wet bulb. Garments subjected to this combination of heat and air movement dry and finish wrinkle free and ready to wear. Garment temperature should not exceed 280°F (138°C). After exiting the tunnel, garments should hang freely and should not be compressed against other garments until they have cooled to below 100°F (38°C).

Dry-to-Dry Type Tunnel Drying/Finishing

After being conditioned in a tumble dryer, garments can be hung on hangers and rapidly and continuously conveyed through an abbreviated finishing cabinet. Steam, heat and forced air agitation minimize wrinkles and allow processing in a short period of time.

Pressing

If pressing is required, a steam-heated hot head press is recommended with a steam pressure of 80 psig (325°F [163°C]) and a steam/bake/vacuum cycle of 5/10/5 seconds. If an electrically heated hot head is used, a temperature of 375°F (191°C) should be used for 20 seconds as a starting point. Garments should be examined for glazing and dye sublimation before adopting these methods on a commercial basis.

SECTION III: HOME LAUNDERING

GARMENTS OF NOMEX® ARAMID FIBER

GENERAL GUIDELINES

Garments of NOMEX® can be washed and dried by any conventional home method, followed by hand ironing if necessary. No special technology is needed for home laundering garments of NOMEX®. However, home procedures may not remove the last traces of very heavy, widespread or ground-in soils, which may be flammable and could adversely affect the thermal protective performance of garments of NOMEX®.

If home laundering does not remove contaminants or contaminant build-up, garments can be periodically dry cleaned or commercially laundered. When garments are contaminated by hazardous materials, only commercial or on-site laundering or dry cleaning should be used with the appropriate wastewater treatment techniques.

The following procedures can help provide optimum cleaning:

Sorting

Garments of NOMEX® should be sorted and washed separately from other garments to prevent contamination with lint of flammable fibers.

Pretreating

Stains, as well as deep soil lines on the collars and cuffs of garments, are more readily removed if pretreated. Stains should be pretreated at the earliest opportunity and sufficient time allowed for the pretreatment material to penetrate and loosen the soil. The heavily soiled or stained areas should be rubbed with a full-strength, heavy-duty liquid detergent or any off-the-shelf laundry pretreatment product.

Preparing the Wash Load

Before laundering garments of NOMEX®, pockets should be emptied, pants cuffs cleaned out and zippers closed.

Load Size

When laundering garments of NOMEX®, it is important not to overload the machine. To ensure a clean wash and avoid setting wash wrinkles, the load size must permit clothes to move freely through the wash water and rinse cycle. Regardless of the machine's rated capacity in pounds, bulk — not weight — should be the limiting factor.

Wash Water Temperature

Moderate soil levels may be removed adequately at normal wash water temperature settings. Heavily soiled and stained garments of NOMEX® require a higher water temperature setting.

Detergents

Synthetic, heavy-duty liquid laundry detergents are recommended for washing garments of NOMEX®. These "designed" products do a superior job of removing soils and are less likely than soap to form sticky deposits of lime soap curds, which are difficult to rinse out. Fatty-based soaps should not be used. Under-use of detergent results in poor soil removal and frequently causes suspended soils to redeposit on the clothes. Failure to use a sufficient amount of detergent is the single greatest cause of inadequate home cleaning.

Water and Water Conditioners

For best results, an adequate supply of "soft" water is required for home laundering garments of NOMEX®. "Hard" water contains minerals, such as calcium and magnesium salts, that combine with fatty-based soaps to form insoluble film, scum or curd. These insoluble contaminants are difficult to rinse from fabrics, may be flammable and could adversely affect the thermal protective performance of garments if not adequately removed. Soap is not recommended, but if it is used in hard wash water (more than approximately 7 grains/gal., 120 mg/L or 120 ppm), a nonprecipitating-type water conditioner should be added. Softening the water reduces soap consumption and improves the quality of washing.

Bleaches

Only oxygen-based bleaches should be used on garments of NOMEX* — *chlorine bleach should not be used.* Although chlorine bleach will not affect the inherent flame resistance of NOMEX*, it may cause strength and color loss in garments over time.

Fabric Softeners and Anti-Stats*

Under normal conditions, garments of NOMEX* IIIA do not require the use of anti-stats because NOMEX* IIIA contains a proprietary static-dissipative fiber. Nevertheless, numerous washer- and dryer-applied fabric softeners are available for use in home laundry equipment. These products improve the "feel" of items of NOMEX* and can reduce the nuisance effects of static electricity — such as lint pick-up and clinging — that are often experienced with textiles. However, they are not as effective as industrial anti-stats applied in the wash wheel.

NOTE: Anti-static additives cannot ensure safety in situations where a discharge of static electricity could create a potential hazard to life or property. If garments of NOMEX* will be worn in an area where explosive or highly flammable materials are present, it is important that personnel and equipment be properly grounded for maximum safety.

Tumble Drying

Garments of NOMEX* will have a smoother appearance when tumble dried instead of being line or drip dried. To ensure maximum removal of wrinkles, tumble dryers should not be overloaded.

Drying time varies with the nature and size of the load. Garments of NOMEX* dry faster than all-cotton garments of the same weight. When tumble dried at the medium- or high-temperature setting, a properly sized load usually dries in approximately 20 minutes.

Machines designed to give the best automatic wash-and-wear or durable-press performance are programmed so that the blower fan and clothes drum continue to operate five to 10 minutes after the heater turns off. This provides a cool-down period for the garments and helps minimize wrinkles. Tumble dryers with this capability usually feature a control dial or push button with a "Wash-and-Wear" or "Durable Press" setting that provides the proper temperature and a cool-down cycle.

Ironing

If garments of NOMEX* need touch-up pressing, a steam or dry iron may be used at the medium setting.

*Most dryer sheet and some liquid fabric softener products contain disclaimers from the manufacturer stating their product should not be used on children's sleepwear or FR garments. If used in home laundry applications, products with no disclaimer should be selected.

SECTION IV: DRY CLEANING GARMENTS OF NOMEX® ARAMID FIBER

.....

GENERAL GUIDELINES

There are times when dry cleaning garments of NOMEX® is desirable for economic reasons or because greases and oils cannot be adequately removed during home or commercial laundering. Garments of NOMEX® can be satisfactorily dry cleaned in any conventional commercial dry-cleaning system. With heavily soiled garments, using a two-bath cycle may improve soil removal and minimize redeposition. Garments of NOMEX® should be cleaned separately from articles of other materials to avoid contamination with lint of flammable fibers. The practice of maintaining a clean solvent supply must be observed.

No special technology exists for applying anti-stat treatments to garments of NOMEX® during dry cleaning. Some suppliers to the dry-cleaning industry offer anti-stat treatments for dresswear that also can be used with uniforms of NOMEX®. If equipment is available, dry-cleaned garments of NOMEX® also can be treated with AVITEX® DN softener from a water solution, as described in the commercial laundering section of this bulletin.

SECTION V: REMOVING SPOTS AND OTHER NON-STANDARD CONTAMINANTS FROM GARMENTS OF NOMEX® ARAMID FIBER

GENERAL GUIDELINES

Properly dyed and finished garments of NOMEX® are flame resistant. However, flame resistance can be compromised by the presence of flammable contaminants on the garment, or on the fabric from which it is made. Paint, heavy oily soils or other flammable materials encountered in an industrial environment can pose a hazard if not removed from the garment. In addition, these contaminants are unsightly and detract from the professional appearance of a high-quality garment.

For work assignments where employees are routinely exposed to paint, epoxy or other difficult- or impossible-to-remove contaminants, the use of flame-retardant disposable coveralls as overgarments should be considered. This will minimize the cleaning task and prolong the life of the garment of NOMEX®. When accidental exposures occur, the contaminant should be removed as soon as possible before it sets in or dries. And, the contaminated garment should be clearly identified so the cleaning facility can spot clean the garment before routine laundering or dry cleaning.

The NOMEX® fiber is resistant to most chemicals typically used to launder, dry clean or spot clean garments, including special laundry detergent/solvent emulsifier formulations designed to remove paint, tar, adhesives and other difficult-to-clean stains. These special formulations can be used as either spot cleaners or as laundry or dry-cleaning additives. As an added precaution, they should be checked for compatibility with fabric of NOMEX® before any contaminant removal is attempted. The chemical supplier's spotting and cleaning procedure recommendations should be followed.

Because these formulations may contain flammable solvents, garments should be cleaned by standard cleaning methods after spot cleaning. When chemical additives are used in laundering or dry cleaning, garments should be thoroughly rinsed to ensure the removal of any residual flammable solvents.

Several technical bulletins describing the resistance of NOMEX® to various chemicals are available through the DuPont Product Information Center (800-441-7515) or the DuPont Aramids Telemarketing Group (800-453-8527).

APPENDIX I: SOURCE LIST FOR LAUNDERING PRODUCTS*

Product/Trademark	Detergent Vendor
Alert	Ecolab, Textile Care
Dynalite/Force	370 Wabasha Street
Innovator Ultra Liquid	St. Paul, MN 55102
Innovator Ultra Powder	(800) 553-8683
Factor Plus*	Diversity Fabrilife
Liquid Factor* I	4480 Lake Forest Drive
Liquid Factor* II	Cincinnati, OH 45242
	(800) 862-8883
Surpass 2	U.N.X., Inc.
	P.O. Box 7206
	Greenville, NC 27835-7206
	(919) 756-8616
Choice	Washing Systems, Inc. (WSI)
	1865 Summit Road
	Cincinnati, OH 45237
	(800) 272-1WSI (272-1974)
Product/Trademark	Softeners/Anti-Stats Vendor
AVITEX* DN	DuPont Company
	Specialty Chemicals
	1007 Market Street
	Wilmington, DE 19898
	(800) 441-9442
Product/Trademark	Antifoams Vendor
Dow Corning*	Dow Corning
Antifoam 1430	PHAC Customer Service
	P.O. Box 0994
	Midland, MI 48686-0994
	(800) 362-6373
Product/Trademark	Water/Oil Repellents Vendor
Winsol* Fireline	Winsol Laboratories
Water Repellent	1417 N.W. 51st Street
	Seattle, WA 98107
	(800) 782-5501
ZONYL* 6991	DuPont Company
	Specialty Chemicals
	1007 Market Street
	Wilmington, DE 19898
	(800) 441-9442

NOTE: Listing of products in this appendix does not indicate a DuPont endorsement. Other products not listed in this appendix also may be acceptable laundering products for garments of NOMEX* aramid fiber. Other products that have not been tested but that belong to the same class of low temperature, low alkalinity, high surfactant-based products also may provide acceptable results.

APPENDIX II: SUGGESTED WASH PROCEDURE FOR LIGHTLY SOILED GARMENTS OF NOMEX® ARAMID FIBER*

Operation	Water Level, in. (cm)	Water Temp., °F (°C)	Time, min.	Supplies**/100 lb (45 kg) of Garments
Break	6 (15)	140 (60)	15	2.5 lb (1.1 kg) recommended detergent
Rinse	10 (25)	140 (60)	3	
Rinse	10 (25)	135 (57)	3	
Rinse	10 (25)	120 (49)	3	
Rinse	10 (25)	105 (41)	3	
Rinse	10 (25)	90 (32)	3	
Sour	6 (15)	Cold	10	1-4 oz. ammonium silicofluoride
Softener/Anti-Stat (optional)				AVITEX® DN***

*Load wheel to ¾ of its rated capacity.

**See Appendix I for laundry supplies.

***If used, apply 0.50% to 0.75% on weight of dry fabric, as described in text and Appendices IV and V.

APPENDIX III: SUGGESTED WASH PROCEDURE FOR HEAVILY SOILED GARMENTS OF NOMEX® ARAMID FIBER*

Operation	Water Level, in. (cm)	Water Temp., F (°C)	Time, min.	Supplies**/100 lb (45 kg) of Garments
Break	6 (15)	160 (71)	20	2.5-3 lb (1.1-1.4 kg) recommended detergent
Flush	8 (20)	160 (71)	3	
Suds	6 (15)	160 (71)	10	1.25-1.5 lb (0.5-0.7 kg) recommended detergent
Rinse	10 (25)	160 (71)	3	
Rinse	10 (25)	160 (71)	3	
Bleach	10 (25)	150 (66)	5	oxygen-based bleach only
Rinse	10 (25)	150 (66)	3	
Rinse	10 (25)	135 (57)	3	
Rinse	10 (25)	120 (49)	3	
Rinse	10 (25)	105 (41)	3	
Sour	6 (15)	Cold	10	1-4 oz. ammonium silicofluoride
Softener/Anti-Stat (optional)				AVITEX® DN***

*Load wheel to ¾ of its rated capacity.

**See Appendix I for laundry supplies.

***If used, apply 0.50% to 0.75% on weight of dry fabric, as described in text and Appendices IV and V.

APPENDIX IV: APPLICATION OF AVITEX® DN SOFTENER/ANTI-STAT

Definitions

- **Add-On** — The calculated percentage of AVITEX® DN added to the dry weight of the goods. (AVITEX® DN is not substitutive to NOMEX® aramid fiber. This calculation assumes that none of the "as received" formulation is lost due to evaporation during the drying cycle.)
- **Wet Pickup** — The percentage of liquid* carried by the goods that contains AVITEX® DN after the final cycle of the wash wheel.

$$\% \text{ Wet Pickup} = \frac{\text{wet weight}^{\text{***}} - \text{dry weight}}{\text{dry weight}} \times 100$$

- **Solution Concentration** — The percentage of AVITEX® DN in the final cycle of the wash wheel.
- $$\% \text{ Solution Concentration} = \frac{\text{AVITEX}^{\circ} \text{ DN added, gal. (or L)}}{\text{total water in wheel, gal. (or L)}} \times 100$$

Discussion

Add-on is related to solution concentration and wet pickup in the following manner:

$$\% \text{ Add-on} = \frac{\% \text{ solution concentration} \times \% \text{ wet pickup}}{100}$$

When two of these three factors are known, the third can be easily calculated. Generally, the amount of add-on is set at the desired level. Then, with a known wet pickup, the needed solution concentration (i.e., AVITEX® DN) can be calculated. AVITEX® DN is added to the wash wheel to give this concentration and the subsequent calculated add-on.

Example 1

Given:

Wash Wheel: Open pocket, 42 in. x 96 in.
(107 cm x 244 cm), 400 lb (181 kg)
capacity

Load: 300 lb (136 kg) garments of NOMEX® III
aramid fiber

Water Level: 6 in. (15 cm) running, loaded

Total Water in Wheel: 160 gal. (606 L)

Plant Process: Wash/light extract/tumble dry finish

Wet Weight Pickup: 55% (determined after
extraction; see definitions)

Problem:

Using this information, determine:

- (1) The wash wheel solution concentration needed to give a calculated add-on of 0.5% of AVITEX® DN; and
- (2) The amount of AVITEX® DN that must be added to the wash wheel to give this solution concentration.

Solution:

$$\% \text{ Add-On} = \frac{\% \text{ solution concentration} \times \% \text{ wet pickup}}{100}$$

$$\frac{1}{\% \text{ solution concentration}} = \frac{\% \text{ wet pickup}}{\% \text{ add-on} \times 100}$$

$$\% \text{ Solution Concentration} = \frac{\% \text{ add-on} \times 100}{\% \text{ wet pickup}} = \frac{0.5 \times 100}{55} = 0.91$$

*Based on the dry weight of the goods.

**As the goods enter the final drying operation. Wet pickup depends on a number of factors, including whether or not the goods are extracted and, if so, how much? Wet pickup must be determined for each laundry procedure and, like other variables, must be redetermined if the laundry process is altered significantly.

***Varies with running water level in wheel. Must be determined by actual measurement, or calculated from the equipment manufacturer's specifications. Include water required to saturate clothes, as well as "free" water typically given in tables.

The wash wheel contains a total of 160 gal. (606 L) of water. The number of gallons (liters) of AVITEX® DN softener that must be added to give a 0.91% concentration can be approximated by using the following formula:

$$\text{AVITEX}^{\circ} \text{ DN} = \frac{\text{total water} \times \% \text{ solution concentration}}{100} = \frac{160 \text{ gal. (606 L)} \times 0.91}{100} = 1.46 \text{ gal. (5.5 L)}$$

Example 2

Given:

Wash Wheel: Open pocket, 42 in. x 96 in.
(107 cm x 244 cm), 400 lb (181 kg)
capacity

Load: 300 lb (136 kg) garments of NOMEX® III
aramid fiber

Water Level: 6 in. (15 cm) running, loaded

Total Water in Wheel: 160 gal. (606 L)

Plant Process: Wash/hang/wet-to-dry tunnel finish

Wet Weight Pickup: 95% (determined at entrance to
tunnel finisher)

Problem:

Using this information, determine:

- (1) The solution concentration needed to give an add-on of 0.5% of AVITEX® DN; and
- (2) The amount of AVITEX® DN that must be added to the wash wheel to give this solution concentration.

Solution:

$$\% \text{ Add-On} = \frac{\% \text{ solution concentration} \times \% \text{ wet pickup}}{100}$$

$$\frac{1}{\% \text{ solution concentration}} = \frac{\% \text{ wet pickup}}{\% \text{ add-on} \times 100}$$

$$\% \text{ Solution Concentration} = \frac{\% \text{ add-on} \times 100}{\% \text{ wet pickup}} = \frac{0.5 \times 100}{95} = 0.53$$

The wash wheel contains a total of 160 gal. (606 L) of water. The number of gallons (or liters) of AVITEX® DN needed to give a 0.53% concentration can be approximated by using the following formula:

$$\text{AVITEX}^{\circ} \text{ DN} = \frac{\text{total water} \times \% \text{ solution concentration}}{100} = \frac{160 \text{ gal. (606 L)} \times 0.53}{100} = 0.85 \text{ gal. (3.2 L)}$$

APPENDIX V: SOFTENER/ANTI-STAT ADDITIONS CHART

Use the chart below to obtain an add-on of 0.50% of AVITEX® DN softener/anti-stat after determining the percentage of wet pickup of garments and the total number of

gallons (or liters) of water in the wheel. The gallons (or liters) of AVITEX® DN to add to the wheel can be found at the intersection of the appropriate columns.

Wet Pickup,%**	Total Water in Wheel,* gal. (L)				
	30 (114)	50 (189)	100 (379)	200 (757)	300 (1,136)
30	0.50 (1.9)	0.83 (3.1)	1.50 (5.7)	3.33 (12.6)	5.00 (18.9)
40	0.38 (1.4)	0.62 (2.3)	1.25 (4.7)	2.50 (9.5)	3.80 (14.4)
50	0.30 (1.1)	0.50 (1.9)	1.00 (3.8)	2.00 (7.6)	3.00 (11.4)
60	0.25 (0.9)	0.42 (1.6)	0.83 (3.1)	1.70 (6.4)	2.50 (9.5)
70	0.21 (0.8)	0.36 (1.4)	0.71 (2.7)	1.40 (5.3)	2.10 (8.0)
80	0.18 (0.7)	0.31 (1.2)	0.63 (2.4)	1.25 (4.7)	1.80 (6.8)
90	0.17 (0.6)	0.28 (1.1)	0.56 (2.1)	1.10 (4.2)	1.70 (6.4)
100	0.15 (0.6)	0.25 (0.9)	0.50 (1.9)	1.00 (3.8)	1.50 (5.7)
110	0.14 (0.5)	0.23 (0.9)	0.45 (1.7)	0.90 (3.4)	1.40 (5.3)
120	0.13 (0.5)	0.21 (0.8)	0.42 (1.6)	0.83 (3.2)	1.30 (4.9)
130	0.12 (0.5)	0.19 (0.7)	0.38 (1.4)	0.77 (2.9)	1.20 (4.5)
140	0.11 (0.4)	0.18 (0.7)	0.36 (1.4)	0.71 (2.7)	1.10 (4.2)
150	0.10 (0.4)	0.17 (0.6)	0.33 (1.2)	0.66 (2.5)	1.00 (3.8)

*Tables provided by wash wheel manufacturers typically give only the amount of water (1 gal. or 3.78 L) that must be added to a saturated running load to bring the water level up to a specified height (1 in. or 2.54 cm). Add to this amount the amount of water required to saturate the load, usually estimated to be 0.3 gal./lb (2.5 L/kg) of goods in the wheel.

**See Appendix IV.

APPENDIX VI: EXHAUSTION PROCEDURE FOR ZONYL® 6991 APPLICATION*

.....

Adding ZONYL® 6991 is the last procedure in the wash cycle. It should be added with agitation at water temperatures at or below 100°F (38°C). This procedure results in an exhaustion of approximately 80% of the active ingredients onto the fabric.

Guidelines for Application

- In the last rinse cycle, use either citric or acetic acid to adjust the pH of the water to between 4.5 and 5.5.
- After adjusting the pH, add ZONYL® 6991 with agitation at a water temperature of 100°F (38°C) or less.
- With continued agitation, raise the water temperature to a minimum of 120°F (49°C) and hold for five to 10 minutes. Higher water temperatures (up to 160°F [71°C]) will aid in the application of ZONYL® 6991.
- After application of ZONYL® 6991, drop the water bath and extract the garments. Do not rinse garments.
- After extraction, dry garments according to care instructions. For garments of NOMEX®, use a maximum stack temperature of 160°F (71°C). Drying is important to ensure proper performance of the ZONYL® 6991.

*Refer to the ZONYL® 6991 Technical Bulletin.

**FOR MORE INFORMATION,
PLEASE CALL 1-800-453-8527 OR WRITE:**

DuPont
Advanced Fibers Systems
Chestnut Run Plaza
Laurel Run Building
Wilmington, DE 19880-0705

We believe that this information is the best currently available on the subject. It is offered as a suggested starting point for experimentation you may care to undertake in this area. It is subject to revision as additional knowledge and experience are gained. DuPont makes no guarantee of results and assumes no obligation or liability whatsoever in connection with this information. Those intending to use recommendations contained in this publication concerning equipment, processing techniques or chemical products should first satisfy themselves that the recommendations are suitable for their use and meet all appropriate safety and health standards. This publication is not a license to operate under, or intended to suggest infringement of, any existing patents.

Rapidly advancing knowledge of new, long-term toxic effects of many chemicals has emphasized the need to reduce human exposure to many chemicals to the lowest practicable limits. Special hazards with respect to chemicals mentioned in this bulletin that were known to us at the time of publication have been noted in the text or in footnotes, but we do not suggest or guarantee that other hazards do not exist. We strongly recommend that processors seek and adhere to manufacturer's or supplier's current instructions for handling each chemical they use.

Replaces and obsoletes Bulletin NX-12, 7/78
H-71603, Rev 2/97 Printed in U.S.A.



Nomex®

Only by DuPont